



DRUM HANDLING EQUIPMENT & SPECIALTY CONTAINERS



DRUM CRUSHERS/COMPACTORS



HYDRAULIC DRUM DUMPERS



FORK MOUNTED DRUM LIFTERS



DRUM TRANSPORTERS



CYLINDER EQUIPMENT



PAILS AND BOTTLES

| | |
|--|-----------------------|
| Drum Crushers/Compactors V | 286, 333 |
| Drum Racks & Positioners V | 286-288, 292, 334 |
| Hydraulic Drum Dumpers V I | 289-290, 332 |
| Drum Carriers/Rotators V | 290-292, 294 |
| Fork Mounted Drum Lifters V R | 291-292 |
| Drum Grippers V I | 293 |
| Drum Transporters, Trucks, Carts & Jacks V R I | 288, 290-291, 294-299 |
| Retention Basins & Containers V R I | 300-303 |
| Overhead Drum Lifters V R I | 303-308 |
| Dollies for Drums & Pails V I | 308-309 |
| Drums, Liners, and Covers R I | 310-311, 313-314 |
| Drum Deheaders, Wrenches, Sockets, Faucets, & Pumps R I ... | 312, 315-319 |
| Cylinder Equipment V R I | 319-325 |
| Pail Equipment & Pails V R I | 326-331 |



Hydraulic Drum Crusher/Compactors

Crushes 55 gallon steel drums to approximately 6" high. Full cycle time is 25 seconds crush and retract. This unit is designed for a duty cycle that will allow for crushing or compacting up to 250 drums per week in a typical, non-hazardous, indoor, room temperature environment when operated on a three-phase power supply. 38,000 pounds of crushing force. The included drum compacting feature allows you to compact contents inside the drum by simply removing the drum crushing plate. Crushing feature will work with any drum size up to 55 gallons. Compacting feature will only work with 55 gallon drums. Safety features include a pressure relief valve, which prevents overload, and a double door latch to secure the door when crushing. Plus an interlock system that will prevent the motor from running unless the door is closed. 6.5 hp motor, 3-phase, 60 hz. Choose from 208V, 230V, or 460V. Meets OSHA 1910.212 / ANSI Z245.5 / JIC standards. Built-in fork pockets aid in transporting, Aluminum drip pan for catching any excess liquid that may be expelled during the crushing operation. The pan holds 1 gallon and measures 31½" W x 4½" L x 1⅝" H. Replacement and additional drip pans are available. Crating is recommended for international shipments, contact factory.

| MODEL NUMBER | DESCRIPTION | WEIGHT (POUND) |
|--------------------------|---|----------------|
| HDC-905-IDC/460V | CRUSHER/COMPACTOR, 460V, 3-PHASE | 1570 |
| HDC-905-HC/460V | CRUSHER/COMPACTOR, 460V, W/HIGH CYCLE PACKAGE | 2148 |
| HDC-905-IDC/230V | CRUSHER/COMPACTOR, 230V, 3-PHASE | 1570 |
| HDC-905-HC/230V | CRUSHER/COMPACTOR, 230V, W/HIGH CYCLE PACKAGE | 2148 |
| HDC-905-IDC/208V | CRUSHER/COMPACTOR, 208V, 3-PHASE | 1570 |
| HDC-905-HC/208V | CRUSHER/COMPACTOR, 208V, W/HIGH CYCLE PACKAGE | 2148 |
| HDC9-1 | OPTIONAL 3HP POWER UNIT, 1-PHASE (OPTION FOR HDC-905-IDC) AT 208-230V, CYCLE TIME INCREASES TO 70 SEC. AND REQUIRES 20 AMP SUPPLY CIRCUIT. | |
| HDC-905-WD | OPTIONAL WASHDOWN MOTOR & NEMA 4 ENCLOSURE | |
| HDC-905-DPN [Ⓞ] | EXTRA ALUMINUM DRIP PAN 31½" x 4½" x 1⅝" (1 GALLON CAPACITY) | 4 |

Mobile Gasoline Powered Drum Crusher

Take the Drum Crusher to where the drums are! Full cycle time is 25 seconds crush and retract. Features an 570cc Briggs & Stratton gasoline engine. Hydraulic reservoir holds up to 30 gallons of hydraulic oil. Power tilt and integral trailer with tail and brake lights are included. Exterior tension mounted twin cylinders eliminate rod buckling and damage. Unit ships flat bed truck.

| MODEL NUMBER | DESCRIPTION | WEIGHT (POUND) |
|--------------|--------------------------|----------------|
| HDC-900-GPT | GAS POWERED DRUM CRUSHER | 3400 |

Manual Trash Compactors

This easy to use product is designed for compacting the contents of 30 and 55 gallon drums. Manual ratcheting mechanism has 7,000 pounds of compacting force. Ratchet mechanism is also used to retract compacting plate. Compacting plate direction is adjusted with selector levers. Ratchet lever is secured in the UP position with locking pin. Includes two (2) wheels for tilt-and-roll portability of unit when empty. Drum not included. Baked-in powder-coated toughness.

| MODEL NUMBER | DRUM TYPE (GALLON) | SERVICE RANGE | COMPACTOR HEAD DIAMETER/THICKNESS | OVERALL SIZE (W x D x H) | WEIGHT (POUND) |
|--------------|---------------------------------|---------------|-----------------------------------|---|----------------|
| MTC-55 | 55 | 1¼" to 35¾" | 21" / ¼" | 32⅞" x 24¼" x 85 ⁹ / ₁₆ " | 249 |
| MTC-30 | 30 | 1¼" to 35¾" | 17" / ¼" | 32⅞" x 24¼" x 85 ⁹ / ₁₆ " | 202 |
| MTC-RB | OPTIONAL ROLL-OUT BASE ASSEMBLY | | | | 60 |



Polyethylene Drum Racks

Polyethylene Drum Racks capture spills while keeping your workplace clean and safe. All models tilt the drums slightly forward, allowing maximum drainage and optimizing the use of chemicals while minimizing waste. These improve worker safety by keeping slippery chemicals and oils off the floor.

| MODEL NUMBER | DRUM CAPACITY | OVERALL SIZE (W x D x H) | UNIFORM CAPACITY | CONTAINMENT CAPACITY | WEIGHT (POUND) |
|--------------|---|--------------------------|------------------|----------------------|----------------|
| PDR-2 | (2) 55 GAL. | 53" x 53" x 44¾" | 1,500 lb. | 66 GALLON | 137 |
| PDR-4 | (4) 55 GAL. | 53" x 53" x 77¾" | 3,000 lb. | 66 GALLON | 189 |
| PDR-SHF | OPTIONAL DISPENSING SHELF (22"W x 17"L x 5"H) | | | | 15 |

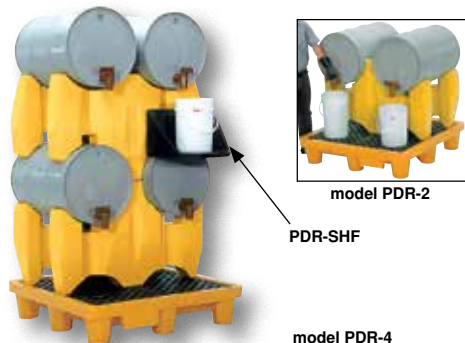

Stackable Drum Racks

Steel Drum Racks accommodate 55 gallon drums and feature four-way fork truck access. Not recommended for stacking more than four (4) racks high. All steel construction with 1/4" formed steel cradles. Bolt together assembly with hardware included. Yellow painted finish. Models with suffix -SS are stainless steel. Models with suffix -G are galvanized. Drums, drum racks, and drum carts all sold separately.

Models DR-CART-2 & DR-CART-3 Portable Drum Dollies accommodate one drum rack and feature two (2) 8" swivel casters and two (2) 8" swivel casters with wheel brake.

Models DR-CART-2-HLK & DR-CART-3-HLK Portable Drum Carts feature removable push handle and two (2) 8" swivel casters and two (2) 8" swivel casters with wheel brake.

| MODEL NUMBER | DRUM CAPACITY | OVERALL SIZE (W x D x H) | UNIFORM CAPACITY | WEIGHT (POUND) |
|-------------------------------|---------------|--------------------------|------------------|----------------|
| DRUM RACKS | | | | |
| DRUM-RACK-2 [Ⓢ] | 2 | 45½" x 29⅞" x 12¾" | 1,600 lb. | 51 |
| DRUM-RACK-3 [Ⓢ] | 3 | 71½" x 29⅞" x 12¾" | 2,400 lb. | 101 |
| DRUM-RACK-2-G | 2 | 45½" x 29⅞" x 12¾" | 1,600 lb. | 90 |
| DRUM-RACK-3-G | 3 | 71½" x 29⅞" x 12¾" | 2,400 lb. | 105 |
| DRUM-RACK-2-SS | 2 | 45½" x 29⅞" x 12¾" | 1,600 lb. | 90 |
| DRUM-RACK-3-SS | 3 | 71½" x 29⅞" x 12¾" | 2,400 lb. | 101 |
| PORTABLE DRUM DOLLIES* | | | | |
| DR-CART-2 | 2 | 30⅝" x 46½" x 14⅑" | 1,600 lb. | 102 |
| DR-CART-3 | 3 | 30⅝" x 72½" x 14⅑" | 2,400 lb. | 155 |
| PORTABLE DRUM CARTS* | | | | |
| DR-CART-2-HLK | 2 | 30⅝" x 54⅞" x 39⅓" | 1,600 lb. | 102 |
| DR-CART-3-HLK | 3 | 30⅝" x 80⅓" x 39⅓" | 2,400 lb. | 155 |

*DRUM RACKS SOLD SEPARATELY

Horizontal Drum Storage Racks

Horizontal Drum Storage Racks provide orderly storage for 30 & 55 gallon drums. Constructed of heavy duty steel angle and cross bracing is provided for extra strength. The uprights keep drums from accidental roll off and allows forklift entry from the front or rear. Four (4) anchor pads help to prevent tipping. Color is yellow with blue cross braces. Survey sheet for model DRK-SRS-2 available on page 334. Ships knock-down, assembly required.

| MODEL NUMBER | DESCRIPTION | OVERALL SIZE (W x D x H) | UNIFORM CAPACITY | WEIGHT (POUND) |
|---------------|-----------------------------------|--------------------------|------------------|----------------|
| DRK-1-3 | 3-DRUM RACK | 34⅞" x 34⅓" x 74⅑" | 2,400 lb. | 205 |
| DRK-2-2 | 4-DRUM RACK | 60⅞" x 34⅓" x 53⅞" | 3,200 lb. | 208 |
| DRK-3-2 | 6-DRUM RACK | 85⅓" x 34⅓" x 53⅞" | 4,800 lb. | 274 |
| DRK-2-3 | 6-DRUM RACK | 60⅞" x 34⅓" x 74⅑" | 4,800 lb. | 268 |
| DRK-3-3 | 9-DRUM RACK | 85⅓" x 34⅓" x 74⅑" | 7,200 lb. | 359 |
| DRK-SRS-2* | 2-DRUM RACK | 61½" x 35½" x 31¼" | 1,600 lb. | 195 |
| DRK-PRDC-42-R | OPTIONAL REVOLVING DRUM CRADLE | | 800 lb. | 28 |
| DRK-PRDC-DPN | OPTIONAL DRIP PAN W/ STEEL HOLDER | | --- | 5 |

*THREE IS THE RECOMMENDED NUMBER THAT CAN BE STACKED ON TOP OF EACH OTHER.

Pallet Rack Drum Cradles

Pallet Rack Drum Cradles convert standard (42 inch) pallet racks into a versatile horizontal drum cradle. The unit works with either box beams or step beams. Accepts 30 and 55 gallon steel drums. The drum angle is adjustable by using the height-adjustment turn knobs (sloping drum allows user to get 3% more fluid out). Works well with the Hydraulic Drum Stacker and the Drum Positioner. Steel construction with baked-in powder-coated toughness.

Model PRDC-42-R features 3" diameter poly rollers that allow manual drum rotation, making faucet and vent installation more convenient.

Model PRDC-DPN includes brackets and prevents leaks from going onto the floor. Usable dimensions: 9¾"W x 7⅞"L x 4⅓"H.

| MODEL NUMBER | OVERALL SIZE (W x L x H) | ACCEPTABLE DRUM TYPES | WEIGHT (POUND) |
|--------------|--|-----------------------|----------------|
| PRDC-42 | 15⅞" x 42½" x 5⅝" | 30 & 55 GALLON STEEL | 36 |
| PRDC-42-R | 17⅞" x 42½" x 6⅓" | 30 & 55 GALLON STEEL | 58 |
| PRDC-DPN | OPTIONAL DRIP PAN W/ STEEL HOLDER (12"W x 14⅑"L x 11⅑"H) | | 5 |
| PRDC-RK-RF | PALLET RACK DRUM CRADLE ROLLER KIT | | 4 |



model
DRUM-RACK-3
(two units shown)



model DR-CART-2

CA Residents see
WARNING A, Pg. 459



model DRUM-RACK-2
with DR-CART-2



Optional drum cradle
DRK-PRDC-42-R and
drip pan with steel
holder DRK-PRDC-DPN



(4) Anchor Pads



model DRK-1-3
shown with optional
drip pan and cradle.
Drums not included.



model PRDC-42



model PRDC-42-R

model PRDC-42
shown with optional
Drum Faucet, model JDFT
(see page I-33)





model DRUM-P-55



model VEDP-55



model HDC-305-72



model HDC-305-96



model HDC-450-72

Drum Positioners

Allows fork truck driver to rotate standing drums to the horizontal racking position and vice-versa. Positive latching system ensures safe handling of drums weighing up to 800 pounds. Slide the positioner extensions over the vertical drum. With the aid of the Drum Positioner, rotate drum to horizontal position. Latching system will engage to allow horizontal positioning of drum. It's now ready to slide into the rack. Mechanical operation relies on fork truck to rotate and lift drums. Fork pockets measure 7½"W x 2½"H usable on 20½" centers. Units feature a welded spacer to protect drum fixtures from damage when rotating.

| MODEL NUMBER | ACCEPTABLE DRUM TYPES | UNIFORM CAPACITY | WEIGHT (POUND) |
|--------------|----------------------------------|------------------|----------------|
| DRUM-P-55 | 55 GALLON STEEL | 800 lb. | 318 |
| DRUM-P-30 | 30 GALLON STEEL & 55 GALLON POLY | 800 lb. | 335 |

Economy Drum Positioner

The Drum Positioner is a unique design to manipulate drums without leaving the fork truck seat. Designed to lift 55 gallon steel drums from the horizontal to the vertical position and vice versa using completely mechanical operation. Ideal for use with drum stands, pallets, and racking. Suitable for loading drums into vehicles. Hinged tines lock automatically when lowered to ground in horizontal position. Fork pockets measure 5½"W x 2"H usable.

| MODEL NUMBER | ACCEPTABLE DRUM TYPES | UNIFORM CAPACITY | WEIGHT (POUND) |
|--------------|-----------------------|------------------|----------------|
| VEDP-55 | 55 GALLON STEEL | 800 lb. | 209 |

Portable Hydraulic Drum Carrier/Rotator/Booms

The Drum Carrier allows one person to lift, transport, and dispense fully loaded 55 gallon steel drums with ease. It features a manual foot pump hydraulic lift and rolls on two (2) 5" x 2" swivel poly-on-steel casters and two (2) 8" x 2" rigid glass-filled nylon wheels. There is a hand crank on the 60" model and chain rotation on the other models to rotate the drum 360°. All models feature a lifting boom attachment, which mounts on the outriggers when not in use on models -60 and 72. Optional power units available. See page 291 for options to handle plastic and fiber drums.

| MODEL NUMBER | ROTATION METHOD | LIFT HEIGHT | UNIFORM CAPACITY | WEIGHT (POUND) |
|-------------------------|-------------------------------------|------------------------------------|------------------|----------------|
| HDC-305-60 | HAND CRANK | 59 ¹¹ / ₁₆ " | 800 lb. | 485 |
| HDC-305-72 | PULL CHAIN | 71 ¹ / ₄ " | 800 lb. | 487 |
| HDC-305-84 | PULL CHAIN | 80 ⁵ / ₈ " | 800 lb. | 687 |
| HDC-305-96 | PULL CHAIN | 97 ⁹ / ₁₆ " | 800 lb. | 708 |
| LIFT OPTIONS | | | | |
| HDC-DC | ONE (1) 12V DC POWER UNIT | | | 96 |
| HDC-AC | 115V AC POWER UNIT | | | 36 |
| HDC-AIR | AIR/OIL OPERATED POWER UNIT | | | 36 |
| ROTATION OPTIONS | | | | |
| HDC-R-DC | DC POWER - TWO (2) 12V BATTERIES | | | 280 |
| HDC-R-HC | HAND CRANK (IN PLACE OF PULL CHAIN) | | | -- |

DRUMS MUST BE FULL TO ROTATE AT RATED CAPACITY

Hydraulic Drum Stackers

Stackers are perfect for positioning 55 gallon steel drums horizontally on shelves. The solid steel construction provides stability during transit. Drums are held in place with a ratchet mechanism. Fully loaded drums rotate 360°. Unit rolls easily on two (2) 8" x 2" glass-filled nylon rigid casters and two (2) 5" x 2" swivel poly-on-steel casters. Comes standard with hydraulic foot pump. Optional power units available.

| MODEL NUMBER | DRUM ROTATION METHOD | LIFT HEIGHT | UNIFORM CAPACITY | WEIGHT (POUND) |
|-------------------------|-------------------------------------|-------------|------------------|----------------|
| HDC-450-60 | HAND CRANK | 60" | 800 lb. | 745 |
| HDC-450-72 | PULL CHAIN | 72" | 800 lb. | 659 |
| HDC-450-84 | PULL CHAIN | 84" | 800 lb. | 709 |
| HDC-450-96 | PULL CHAIN | 96" | 800 lb. | 877 |
| LIFT OPTIONS | | | | |
| HDC-DC | ONE (1) 12V DC POWER UNIT | | | 96 |
| HDC-AC | 115V AC POWER UNIT | | | 36 |
| HDC-AIR | AIR/OIL OPERATED POWER UNIT | | | 36 |
| ROTATION OPTIONS | | | | |
| HDC-R-DC | DC POWER - TWO (2) 12V BATTERIES | | | 280 |
| HDC-R-HC | HAND CRANK (IN PLACE OF PULL CHAIN) | | | -- |

Hydraulic Drum Dumpers 115 V 1-PHASE STANDARD

Hydraulic Drum Dumpers work with 30 and 55 gallon plastic, steel, and fiber drums. The unit has a solid steel chute. Portable units have two (2) rigid and two (2) swivel casters with floor lock screws. All steel construction.

Standard features include: 56 frame, 3/4 HP motor, 115V single phase, 60hz. Upper travel limit switch, safety velocity fuse in cylinder, and vertical adjustment drum restraints are standard. Dumper is operated with a hand held control on a standard 8 ft. long coil cord. Frame, blue and chute, yellow baked-in powder-coated toughness. Having trouble picking the correct model or do you need a custom design? See page 332 for a survey sheet to fill out and return to the factory for help with your unit!

SSC models include a stainless steel chute and base plate. The chutes are constructed with type 304 Stainless Steel in a Mill Finish. Structure on back of chute is painted with Steel-It™ coating. Adjustable height clamps are stainless steel. Steel frame, blue baked-in powder-coated toughness.

PORTABLE HYDRAULIC DRUM DUMPERS

| MODEL NUMBER | DUMP HEIGHT | ROTATION HEIGHT | LEVEL HEIGHT | UNIFORM CAPACITY | WEIGHT (POUND) |
|--------------|-------------|-----------------|--------------|------------------|----------------|
| HDD-36-7-P | 36" | 96" | 63¾" | 750 lb. | 788 |
| HDD-48-7-P | 48" | 116¾" | 72½" | 750 lb. | 864 |
| HDD-60-7-P | 60" | 137¼" | 84½" | 750 lb. | 1019 |
| HDD-72-7-P | 72" | 157½" | 96" | 750 lb. | 1034 |
| HDD-36-10-P | 36" | 96" | 63¾" | 1,000 lb. | 763 |
| HDD-48-10-P | 48" | 116¾" | 72½" | 1,000 lb. | 862 |
| HDD-60-10-P | 60" | 137¼" | 84½" | 1,000 lb. | 1042 |
| HDD-72-10-P | 72" | 157½" | 96" | 1,000 lb. | 1100 |
| HDD-36-15-P | 36" | 96" | 63¾" | 1,500 lb. | 776 |
| HDD-48-15-P | 48" | 116¾" | 72½" | 1,500 lb. | 880 |
| HDD-60-15-P | 60" | 137¼" | 84½" | 1,500 lb. | 1026 |
| HDD-72-15-P | 72" | 157½" | 96" | 1,500 lb. | 1115 |

PORTABLE HYDRAULIC DRUM DUMPERS WITH STAINLESS STEEL CHUTES

| | | | | | |
|-----------------|-----|-------|------|-----------|------|
| HDD-36-7-P-SSC | 36" | 96" | 63¾" | 750 lb. | 788 |
| HDD-48-7-P-SSC | 48" | 116¾" | 72½" | 750 lb. | 864 |
| HDD-60-7-P-SSC | 60" | 137¼" | 84½" | 750 lb. | 1019 |
| HDD-72-7-P-SSC | 72" | 157½" | 96" | 750 lb. | 1034 |
| HDD-36-10-P-SSC | 36" | 96" | 63¾" | 1,000 lb. | 763 |
| HDD-48-10-P-SSC | 48" | 116¾" | 72½" | 1,000 lb. | 862 |
| HDD-60-10-P-SSC | 60" | 137¼" | 84½" | 1,000 lb. | 1042 |
| HDD-72-10-P-SSC | 72" | 157½" | 96" | 1,000 lb. | 1100 |
| HDD-36-15-P-SSC | 36" | 96" | 63¾" | 1,500 lb. | 776 |
| HDD-48-15-P-SSC | 48" | 116¾" | 72½" | 1,500 lb. | 880 |
| HDD-60-15-P-SSC | 60" | 137¼" | 84½" | 1,500 lb. | 1026 |
| HDD-72-15-P-SSC | 72" | 157½" | 96" | 1,500 lb. | 1115 |

STATIONARY HYDRAULIC DRUM DUMPERS

| | | | | | |
|-------------|-----|-------|------|-----------|------|
| HDD-36-7-S | 36" | 95¾" | 60" | 750 lb. | 709 |
| HDD-48-7-S | 48" | 116" | 72" | 750 lb. | 800 |
| HDD-60-7-S | 60" | 136¾" | 84" | 750 lb. | 988 |
| HDD-72-7-S | 72" | 157¼" | 95¼" | 750 lb. | 1013 |
| HDD-36-10-S | 36" | 95¾" | 60" | 1,000 lb. | 727 |
| HDD-48-10-S | 48" | 116" | 72" | 1,000 lb. | 792 |
| HDD-60-10-S | 60" | 136¾" | 84" | 1,000 lb. | 942 |
| HDD-72-10-S | 72" | 157¼" | 95¼" | 1,000 lb. | 1055 |
| HDD-36-15-S | 36" | 95¾" | 60" | 1,500 lb. | 966 |
| HDD-48-15-S | 48" | 116" | 72" | 1,500 lb. | 814 |
| HDD-60-15-S | 60" | 136¾" | 84" | 1,500 lb. | 937 |
| HDD-72-15-S | 72" | 157¼" | 95½" | 1,500 lb. | 1013 |

STATIONARY HYDRAULIC DRUM DUMPERS WITH STAINLESS STEEL CHUTES

| | | | | | |
|-----------------|-----|-------|------|-----------|------|
| HDD-36-7-S-SSC | 36" | 95¾" | 60" | 750 lb. | 709 |
| HDD-48-7-S-SSC | 48" | 116" | 72" | 750 lb. | 800 |
| HDD-60-7-S-SSC | 60" | 136¾" | 84" | 750 lb. | 988 |
| HDD-72-7-S-SSC | 72" | 157¼" | 95¼" | 750 lb. | 1013 |
| HDD-36-10-S-SSC | 36" | 95¾" | 60" | 1,000 lb. | 727 |
| HDD-48-10-S-SSC | 48" | 116" | 72" | 1,000 lb. | 792 |
| HDD-60-10-S-SSC | 60" | 136¾" | 84" | 1,000 lb. | 942 |
| HDD-72-10-S-SSC | 72" | 157¼" | 95¼" | 1,000 lb. | 1055 |
| HDD-36-15-S-SSC | 36" | 95¾" | 60" | 1,500 lb. | 966 |
| HDD-48-15-S-SSC | 48" | 116" | 72" | 1,500 lb. | 814 |
| HDD-60-15-S-SSC | 60" | 136¾" | 84" | 1,500 lb. | 937 |
| HDD-72-15-S-SSC | 72" | 157¼" | 95½" | 1,500 lb. | 1036 |

OPTIONAL 12VDC SYSTEM WITH 115V ON-BOARD CHARGER, MODEL VCC-12VDC
 OPTIONAL 5 GALLON PAIL ADAPTOR FINGERS, MODEL HDD-5G-ADP



PAIL ADAPTOR FINGERS
model HDD-5G-ADP



45° DUMP ANGLE
(135° TOTAL ROTATION)



model
HDD-48-15-P



SPECIALTY POLISH & FINISH OPTIONS

SSC MODELS INCLUDE

- 304 Stainless Steel chute in Mill Finish
- Chute includes Steel-It™ coating standard on any mild steel welded to back of chute
- Steel frame, blue baked-in powder-coated toughness
- Adjustable height clamps are stainless steel
- Can quote different grades of stainless polishing on chutes
- Optional FDA white powder coat is acceptable for incidental food contact



HYDRAULIC DRUM
DUMPER SURVEY
SHEET IS ON
PAGE 332



model
HDD-48-7-S-SSC

Image shows 304 Stainless Steel chute in Mill Finish and optional FDA white powder coat.



model HLD-116-10-P



New

model
ULM-PBT-DTC-10



ULMA
Inostruck

model
ULM-PBT-BTC-10



model DCT-2000

model DCT-85



model DCT-75

See page 291 for options to handle plastic and fiber drums.

Lift-and-Dump Hydraulic Drum Dumpers 460V 3-PHASE STD

Lift-and-Dump Hydraulic Drum Dumpers are what you need to dump drums at variable heights. The HLD works similarly to the HDD, but includes a lift cylinder that allows you to dump at various heights. Features a four (4) push button pendant, which allows the operator full independent control of both lift height and the dump angle.

| MODEL NUMBER | DUMP HEIGHT (MIN / MAX) | ROTATION HEIGHT | LEVEL HEIGHT | UNIFORM CAPACITY | FRAME (W x L) | WEIGHT (POUND) |
|--|-------------------------|-----------------|--------------|------------------|---------------|----------------|
| PORTABLE LIFT AND DUMP DRUM DUMPERS (40° DUMP ANGLE) | | | | | | |
| HLD-94-10-P | 48" / 94" | 163" | 87¾" | 1,000 lb. | 51" x 75¾" | 1372 |
| HLD-116-10-P | 60" / 116" | 194" | 99¾" | 1,000 lb. | 51" x 82¾" | 1460 |
| HLD-94-15-P | 48" / 94" | 163" | 87¾" | 1,500 lb. | 51" x 75¾" | 1392 |
| HLD-116-15-P | 60" / 116" | 194" | 99¾" | 1,500 lb. | 51" x 82¾" | 1525 |
| STATIONARY LIFT AND DUMP DRUM DUMPERS (45° DUMP ANGLE) | | | | | | |
| HLD-94-10-S | 48" / 94" | 163" | 85⅞" | 1,000 lb. | 51" x 65½" | 1341 |
| HLD-116-10-S | 60" / 116" | 194" | 97⅞" | 1,000 lb. | 51" x 72½" | 1522 |
| HLD-94-15-S | 48" / 94" | 163" | 85⅞" | 1,500 lb. | 51" x 65½" | 1454 |
| HLD-116-15-S | 60" / 116" | 194" | 97⅞" | 1,500 lb. | 51" x 72½" | 1466 |
| 12V DC POWERED PORTABLE LIFT AND DUMP DRUM DUMPERS (40° DUMP ANGLE) | | | | | | |
| HLD-94-10-P-DC | 48" / 94" | 163" | 87¾" | 1,000 lb. | 51" x 75¾" | 1432 |
| HLD-116-10-P-DC | 60" / 116" | 194" | 99¾" | 1,000 lb. | 51" x 82¾" | 1526 |
| HLD-94-15-P-DC | 48" / 94" | 163" | 87¾" | 1,500 lb. | 51" x 75¾" | 1452 |
| HLD-116-15-P-DC | 60" / 116" | 194" | 99¾" | 1,500 lb. | 51" x 82¾" | 1585 |
| 12V DC POWERED STATIONARY LIFT AND DUMP DRUM DUMPERS (45° DUMP ANGLE) | | | | | | |
| HLD-94-10-S-DC | 48" / 94" | 163" | 85⅞" | 1,000 lb. | 51" x 65½" | 1401 |
| HLD-116-10-S-DC | 60" / 116" | 194" | 97⅞" | 1,000 lb. | 51" x 72½" | 1582 |
| HLD-94-15-S-DC | 48" / 94" | 163" | 85⅞" | 1,500 lb. | 51" x 65½" | 1514 |
| HLD-116-15-S-DC | 60" / 116" | 194" | 97⅞" | 1,500 lb. | 51" x 72½" | 1526 |
| VOLTAGE OPTION | | | | | | |
| HLD-24VDC | 24V DC POWER OPTION | | | | | -- |

Drum & Bin Dumpers 12V DC POWERED

The 304L Stainless Steel Drum & Bin Dumpers are great for the 'clean' workplace as well as manufacturing facilities. The structure is designed of 304L stainless steel, including hydraulic cylinders as well as the piston, which promotes easy cleaning and long lasting strength. Push button functionality allows the user to move to a precise position and stop the movement completely, in an emergency, with the emergency switch. (1) 12V AGM battery is waterproof, making maintenance a breeze. The unit rolls easily on poly wheels, while traversing from area to area. Once folded, the unit becomes more compact for utilizing less storage space.

| MODEL NUMBER | DESCRIPTION | DUMP HEIGHT | ROTATION HEIGHT | LEVEL HEIGHT | UNIFORM CAPACITY | WEIGHT (POUND) |
|----------------|-------------|-------------|-----------------|--------------|------------------|----------------|
| ULM-PBT-DTC-10 | DRUM DUMPER | 51" | 106" | 51⅞" | 660 lb. | 504 |
| ULM-PBT-BTC-10 | BIN DUMPER | 51" | 106" | 51⅞" | 660 lb. | 452 |

Hoist Mounted Drum Carrier/Rotators

Rotate and position a fully loaded 55 gallon steel drum with ease. Use with an overhead hoist or a fork truck. Fork pockets measure 5½"W x 1⅝"H usable. Features a chain crank that allows the operator to rotate 360° drums that are out of reach. Drums are held in place with a drum locking system. Meets OSHA 1910.179 requirements. *Model DCT-2000* features gear box operation.

| MODEL NUMBER | ACCEPTABLE DRUM TYPES | ROTATION METHOD | UNIFORM CAPACITY | WEIGHT (POUND) |
|--------------|-------------------------------------|-----------------|------------------|----------------|
| DCT-75 | 55 GALLON STEEL | 15' CHAIN | 800 lb. | 145 |
| DCT-85 | 55 GALLON STEEL | 15' CHAIN | 1,500 lb. | 145 |
| DCT-2000 | 55 GALLON STEEL | 15' CHAIN | 2,000 lb. | 169 |
| DCT-R-HC | HAND CRANK (IN PLACE OF PULL CHAIN) | | | 1 |

DRUM MUST BE FULL TO ROTATE AT RATED CAPACITY

Fork Truck Drum Carrier/Rotators

Easily transport and rotate 55 gallon steel drums using a fork truck. Each unit is provided with a 15 foot long chain to allow the drum to be rotated up to 360° from the fork truck operator's seat. Fork pockets measure 7 $\frac{3}{8}$ "W x 2 $\frac{5}{8}$ "H usable, except DCR-205-8 and DCR-205-15 usable is 7"W. DC powered units include two (2) 12V batteries, on-board charger, and hand held control on a 4 foot to 20 foot long coil cord. Safety restraint is used to secure unit to fork truck. Bung Nut Wrench, model BNW-I, is included.

| MODEL NUMBER | CRANK TURNS PER 90° ROTATION | DRUM RESTRAINT METHOD | UNIFORM CAPACITY | WEIGHT (POUND) |
|------------------------------------|--|-----------------------|------------------|----------------|
| 15 FOOT ROTATION PULL CHAIN | | | | |
| DCR-205-8 | 10 | 33" CHAIN | 800 lb. | 222 |
| DCR-205-15 | 10 | 33" CHAIN | 1,500 lb. | 228 |
| DCR-205-20 | 15 | DUAL RATCHET STRAP | 2,000 lb. | 229 |
| 12V DC POWERED | | | | |
| DCR-205-8-DC | -- | 36" CHAIN | 800 lb. | 361 |
| DCR-205-12-DC | -- | 36" CHAIN | 1,200 lb. | 426 |
| DCR-R-815-HC | HAND CRANK (IN PLACE OF PULL CHAIN) FOR DCR-205-8 & DCR-205-15 | | | 1 |
| DCR-R-20-HC | HAND CRANK (IN PLACE OF PULL CHAIN) FOR DCR-205-20 | | | 1 |
| RRC-2PB | WIRELESS REMOTE CONTROL use w/DC units | | | 1 |

DRUM MUST BE FULL TO ROTATE AT RATED CAPACITY

Plastic & Fiber Drum Adapters and Other Upgrades

Designed to hold and support fiber and plastic drums. The FDA-550 (adjusting arms) or the FDA-800 (adjusting arms with nylon strap) unit must be utilized in conjunction with models HDC-305, DCR-205, DCR-110, and DCT.

Model FDA-800 comes complete with both an adjusting arm (FDA-550) and a high strength nylon strap (FDA-250). Works with steel, plastic, and fiber drums measuring 12" to 21" in diameter and 28" to 36" high.

Model FDC-30, attaches to the inner rim of the drum saddle so a 30 gallon steel, fiber, or poly drum can be used. In any application where it is used with fiber or poly drums, it MUST BE used in conjunction with the adjusting arms (either the FDA-550 or FDA-800 models).

Dual Ratchet Strap, *model FDRS*, accommodates 30 and 55 steel gallon drums.

| MODEL NUMBER | DESCRIPTION | ACCOMMODATES DRUM TYPE | WEIGHT (POUND) |
|--------------|---|------------------------|----------------|
| FDA-800 | FIBER DRUM ADAPTER (INCLUDES FDA-550 & FDA-250) | P, F, S | 14 |
| FDA-550 | ADJUSTING ARM (SOLD SEPARATELY) | P, F, S | 13 |
| FDA-250 | NYLON STRAP (SOLD SEPARATELY) | STEEL | 3 |
| FDC-30 | STEEL SADDLE | STEEL | 18 |
| FDRS | DUAL RATCHET STRAP (for DCT, HDC, DCR-205-DC) | STEEL | 12 |
| FDRS-V2 | DUAL RATCHET STRAP (for DCR-205 & DCR-110-55) | STEEL | 24 |

Fork Mounted Poly Drum Handlers

These easy to use plastic drum handlers are designed to handle odd-shaped plastic drums. Includes safety restraint for securing unit to the fork truck. Baked-in powder-coated toughness.

Model FPDL-8-L has adjustable arms that are designed to fit 55 gallon tapered round bottom plastic drums. Low drum attachment point allows for use with both open and closed head drums. A ratchet strap is supplied to secure the drum to the unit when traveling over rough terrain.

Model FPDL-11-H is a top lip plastic drum lifter for use with 30 and 55 gallon plastic closed head drums. 7 $\frac{1}{2}$ " wide x 2 $\frac{1}{2}$ " high usable fork pockets on 20 $\frac{1}{2}$ " centers. High drum attachment point for use with top lip at least $\frac{3}{16}$ " high. Will also work with steel and fiber drums.

| MODEL NUMBER | DESCRIPTION | UNIFORM CAPACITY | OVERALL SIZE (W x L x H) | WEIGHT (POUND) |
|--------------|-------------|------------------|--|----------------|
| FPDL-8-L | BOTTOM GRIP | 800 lb. | 28 $\frac{1}{2}$ " x 56 $\frac{1}{4}$ " x 22 $\frac{3}{8}$ " | 235 |
| FPDL-11-H | TOP GRIP | 1,100 lb. | 28 $\frac{1}{2}$ " x 48 $\frac{3}{8}$ " x 22 $\frac{3}{8}$ " | 196 |

Deluxe Combination Fork Mounted Drum Lifter

Deluxe Combination Fork Mounted Drum Lifter includes attachments to lift any type of drum; 30 and 55 gallon, steel, plastic, fiber. Designed exclusively for lifting closed and open head steel drums with a secured lid installed. Includes single Eagle Beak™ unit and both bottom and top lip Poly Drum Lifters. Uniform capacity will vary depending on which attachment you use. The usable fork pockets are 7 $\frac{1}{2}$ " wide by 2 $\frac{1}{2}$ " high on 20 $\frac{1}{2}$ " centers. Includes a safety restraint for securing unit to fork truck. Welded steel construction. Baked-in powder-coated toughness. A ratchet strap is supplied to secure the drum to the unit when traveling over rough terrain.

| MODEL NUMBER | ACCEPTABLE DRUM SIZE | OVERALL SIZE (W x L x H) | WEIGHT (POUND) |
|--------------|----------------------|--|----------------|
| DFDL-3 | 30 & 55 GALLON | 29" x 56 $\frac{1}{16}$ " x 30 $\frac{1}{8}$ " | 332 |



model DCR-205-15

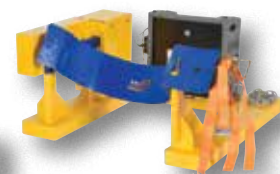

model DCR-205-12-DC



YouTube

48 Hours to Ship



NYLON STRAP
model FDA-250



ADJUSTING ARM
model FDA-550

48 Hours to Ship



DUAL RATCHET STRAP
model FDRS



STEEL SADDLE
model FDC-30

model FPDL-8-L

POWDER COATED TOUGH

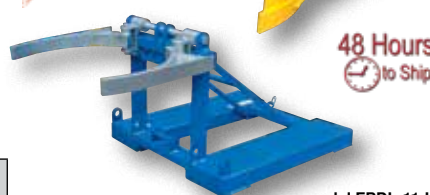

model FPDL-11-H

48 Hours to Ship

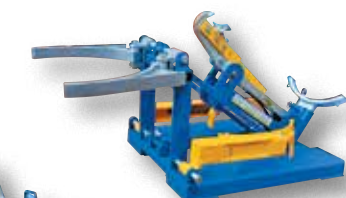

model DFDL-3

POWDER COATED TOUGH



model FMDL-1



48 Hours to Ship



model FMDL-2



ROLLERS
Suffix LDS-R3



BELT
Suffix LDS-B1

Automatic Eagle Beak™ Drum Lifters

This time tested and proven design allows a fork truck operator to easily secure, move, and release drums without leaving the seat of the fork truck. For use with open and closed head (with lid installed and secured) 30 and 55 gallon plastic, steel, and fiber drums with a top lip strong enough to support the weight of the drum. Choose single-drum or double-drum configuration. Includes safety restraint to secure unit to the fork truck. Welded steel construction. Baked-in powder-coated toughness. Fork pockets measure 7½" wide x 2½" high usable on 20½" centers. A ratchet strap is supplied to secure the drum to the unit when traveling over rough terrain. FMDL-1 and FMDL-2 meet OSHA 1910-178 requirements.

| MODEL NUMBER | NUMBER OF DRUMS | UNIFORM CAPACITY | OVERALL SIZE (W x L x H) | WEIGHT (POUND) |
|---------------------|---|------------------|---|----------------|
| FMDL-1 [Ⓞ] | 1 | 1,000 lb. | 28½" x 42 ⁵ / ₈ " x 31¼" | 227 |
| FMDL-2 [Ⓞ] | 2 | 2,000 lb. | 41¼" x 42 ⁵ / ₈ " x 31¼" | 311 |
| WITH ROLLERS | | | | |
| FMDL-1-LDS-R3 | 1 | 1,000 lb. | 28½" x 46½" x 31¼" | 227 |
| FMDL-2-LDS-R3 | 2 | 2,000 lb. | 44 ⁷ / ₈ " x 46½" x 31¼" | 311 |
| WITH BELT | | | | |
| FMDL-1-LDS-B1 | 1 | 1,000 lb. | 28½" x 44 ⁵ / ₈ " x 31¼" | 227 |
| FMDL-2-LDS-B1 | 2 | 2,000 lb. | 45 ⁵ / ₁₆ " x 44 ⁵ / ₈ " x 31¼" | 311 |
| LDS-R3 | OPTIONAL LIFTING DRUM SADDLE ROLLER STYLE | | | 24 |
| LDS-B1 | OPTIONAL LIFTING DRUM SADDLE BELT STYLE | | | 21 |

Fork Mounted Drum Lifters

Fork truck attachments utilize a single automatic clamping mechanism for handling any size steel, plastic, or fiber chimed drum. Scales available, contact factory.

Model FMDL-850 is a knockdown unit that bolts together. Fork pockets and safety chain provide quick and easy installation.

Model FMDDL-1700 can lift two drums. It attaches to fork trucks and walkie stackers.

The following are fork mounted drum lifters that enable fork truck operators to install or remove the attachment in seconds without any tools. Totally enclosed fork pockets with attached safety chain and cam lock secures the attachment to the fork truck.

Models FMDL-1500 & FMDL-2000 - Fork truck attachments utilize a heavy-duty single automatic clamping mechanism for handling steel, fiber, and plastic chimed drums in high volume applications.

Models FMDDL-3000 & FMDDL-4000 feature heavy-duty double articulating clamping mechanisms for handling any steel, plastic, or fiber chimed drums in high volume applications. Each drum is gripped with two (2) upper and lower jaws in heads that are spaced about 6" apart.



model FMDL-850



model FMDL-1500



model FMDL-2000



model FMDDL-3000



model FMDDL-4000

| MODEL NUMBER | ACCEPTABLE DRUM TYPES | UNIFORM CAPACITY | OVERALL SIZE (W x L x H) | WEIGHT (POUND) |
|--------------|-----------------------------|------------------|--------------------------|----------------|
| FMDL-850* | (1) STEEL, PLASTIC OR FIBER | 750 lb. | 31" x 34" x 35" | 170 |
| FMDL-1500 | (1) STEEL, PLASTIC OR FIBER | 1,500 lb. | 33" x 47" x 37" | 340 |
| FMDL-2000 | (1) STEEL, PLASTIC OR FIBER | 2,000 lb. | 33" x 47" x 37" | 366 |
| FMDDL-1700* | (2) STEEL, PLASTIC OR FIBER | 1,500 lb. | 38" x 34" x 35" | 240 |
| FMDDL-3000 | (2) STEEL, PLASTIC OR FIBER | 3,000 lb. | 33" x 47" x 37" | 432 |
| FMDDL-4000 | (2) STEEL, PLASTIC OR FIBER | 4,000 lb. | 33" x 47" x 37" | 482 |

*LIGHT-DUTY UNIT TO HANDLE 100 OR FEWER DRUMS PER MONTH

Horizontal Drum Carrier

Designed exclusively for lifting closed and open-head steel drums with a secured lid installed. Used to load and unload steel drums horizontally in racks. Safety restraint secures cradle to the forks to maximize safety and productivity. Drum lock engages and disengages automatically as a function of the fork angle. Fork pockets measure 7⁵/₈" wide by 2³/₈" high usable.



model HORIZ-70

| MODEL NUMBER | ACCEPTABLE DRUM SIZE | UNIFORM CAPACITY | WEIGHT (POUND) |
|--------------|----------------------|------------------|----------------|
| HORIZ-70 | 55 GALLON | 650 lb. | 161 |



model HDT-500



48 Hours to Ship

Horizontal Drum Positioner

Ideal for loading/unloading drums stored horizontally on drum racking and stands. Suitable for loading drums onto vehicles. Fork opening is 24½" apart and fork pockets are 5½" x 2". Accommodates 22½" diameter by 36" high steel, plastic, and fiber drums.

| MODEL NUMBER | ACCEPTABLE DRUM SIZE | OVERALL SIZE (W x L x H) | UNIFORM CAPACITY | WEIGHT (POUND) |
|----------------------|----------------------|--------------------------|------------------|----------------|
| HDT-500 [Ⓞ] | 55 GALLON | 29" x 55½" x 4¾" | 650 lb. | 115 |

Spring Grip Fork Mounted Drum Gripper

The Drum Gripper creates a functional and efficient way to transport drums from workstation to workstation. The welded steel construction with a baked-in powder-coated toughness, durable and long lasting in the harshest of environments. Once the drum gripper arms are placed around the drum, simply use the ratchet to tighten the arms in place for a firm hold on the drum. After moving the drum to the desired location, release the ratchet tension and un-ratchet until drum is free. The unit has a foldable design for less storage space when not in use. Works with 30, 55, and 85 gallon steel, plastic, and fiber drums. 7⁵/₈"W x 1⁷/₈"H usable fork pocket, 19³/₄" on center.



| MODEL NUMBER | ACCEPTABLE DRUM SIZES | UNIFORM CAPACITY | OPERATION | WEIGHT (POUND) |
|--------------|-----------------------|---|----------------|----------------|
| DGS-AG | 30, 55 & 85 GALLON | 1,500 lb. (STEEL, FIBER) 1,000 lb. (PLASTIC) | MANUAL RATCHET | 164 |

Fork Mounted Drum Grippers

Designed for use with fork trucks fitted with hydraulic lateral fork positioner only. The pair of Fork Mounted Drum Grippers easily attach to your forks for easy drum positioning. Available for use with 30 and 55 gallon steel drums. Secure to forks with friction-lock screw mechanism. Welded steel construction with a baked-in powder-coated toughness.



| MODEL NUMBER | ACCEPTABLE DRUM SIZES | UNIFORM CAPACITY | USABLE FORK OPENING | WEIGHT (POUND) |
|--------------|-----------------------|------------------|---|----------------|
| FDG-55 | 55 GALLON | 800 lb. | 5 ¹ / ₂ "W x 2 ¹ / ₂ "H | 82 |
| FDG-30 | 30 GALLON | 800 lb. | 5 ¹ / ₂ "W x 2 ¹ / ₂ "H | 82 |

Drum Grippers

Drum Grippers make it easy to pick up one or two steel drums without leaving the seat of the fork truck. Simply slip the forks into the fork tubes, fasten the safety restraint and the Drum Gripper is ready to go. The knuckle gripping system is lowered around the drum, gripped tightly, and then lifted into the air. Drum is automatically released by lowering the forks. All models feature hinged folding design for storage.

Model DGS-A-PSD features adjustable-width arms for use with both 30 and 55 gallon steel and plastic drums (with top ring or top ridge). Safety restraint included. Welded steel construction with a baked-in powder-coated toughness.

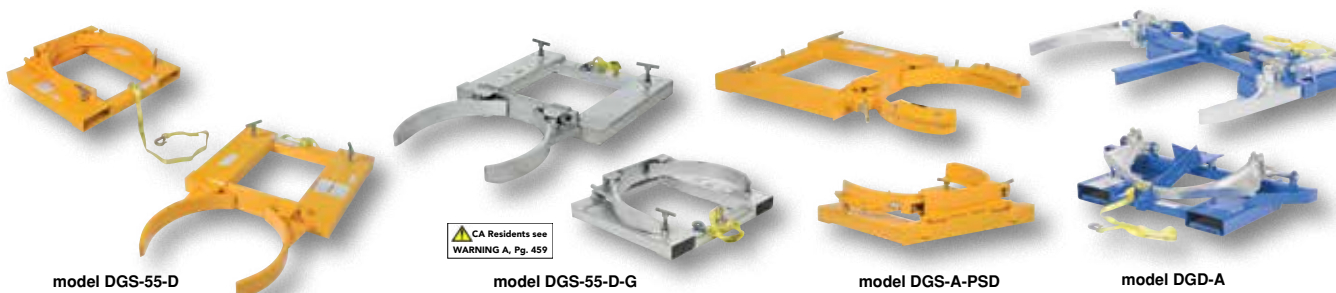
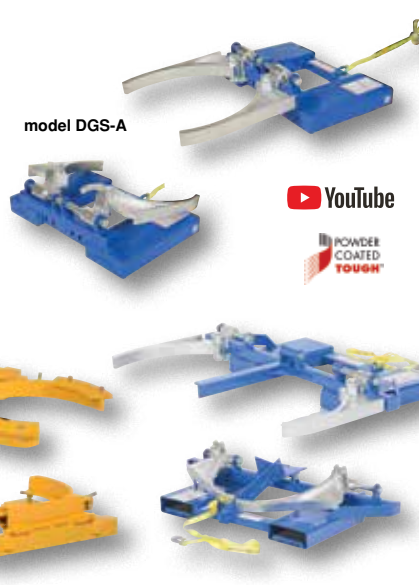

| MODEL NUMBER | ACCEPTABLE DRUM SIZE (GALLON) / FINISH | UNIFORM CAPACITY | OVERALL SIZE (W x D x H) | FORK POCKET CENTERS | FORK POCKET SIZE (W x H) | WEIGHT (POUND) |
|--------------|--|------------------|---|----------------------------------|--|----------------|
| DGS-A | (1) 30 & 55 - BLUE PC | 800 lb. | 27 ³ / ₄ " x 35" x 7 ¹ / ₂ " | 19 ³ / ₄ " | 7 ⁵ / ₈ " x 1 ⁷ / ₈ " | 164 |
| DGD-A | (2) 30 & 55 - BLUE PC | 1,500 lb. | 45" x 35" x 7 ¹ / ₂ " | 24" | 7 ⁵ / ₈ " x 1 ⁷ / ₈ " | 211 |
| DGS-55-D | (1) 55 - YELLOW PC | 1,500 lb. | 28" x 43 ³ / ₁₆ " x 7 ¹ / ₈ " | 20 ¹ / ₄ " | 7 ¹ / ₈ " x 2 ¹ / ₁₆ " | 115 |
| DGD-55-D | (2) 55 - YELLOW PC | 2,000 lb. | 46 ¹ / ₄ " x 43 ⁵ / ₈ " x 9 ³ / ₈ " | 25 ⁷ / ₈ " | 7 ¹ / ₈ " x 2 ⁵ / ₁₆ " | 223 |
| DGS-55-D-G | (1) 55 - GALVANIZED | 1,500 lb. | 28" x 43 ³ / ₁₆ " x 7 ¹ / ₈ " | 20 ¹ / ₄ " | 6 ⁷ / ₈ " x 2 ¹ / ₈ " | 150 |
| DGD-55-D-G | (2) 55 - GALVANIZED | 2,000 lb. | 46" x 24 ¹ / ₄ " x 9 ¹ / ₂ " | 25 ⁷ / ₈ " | 6 ⁷ / ₈ " x 2 ¹ / ₈ " | 258 |
| DGS-A-PSD* | (1) 30 & 55 - YELLOW PC | 1,500 lb. | 28" x 24" x 8" | 20 ¹ / ₂ " | 7 ¹ / ₈ " x 2 ¹ / ₄ " | 147 |

*ACCEPTS STEEL & PLASTIC DRUMS (with top ring or top ridge)



CA Residents see WARNING A, Pg. 459



model
DRUM-LRT-EC



model
DRUM-LRT-ESJ



HAND PUMP LIFT
model DRUM-LRT



model DRUM-LRT-II
shown with option
FDA-550-DRUM-LRT-PF

DC POWER LIFT
model DRUM-LRT-DC



DC POWER LIFT
model DRUM-LRT-DC-II



model
DCR-110-55



Economy Portable Drum Lifter/Rotator/Transporters

Easy to lift, transport, and tilt 55 gallon steel drums. Ideal for use in warehouse environments when moving drums to and from racks. Drums can be locked in a vertical position to avoid spills or a horizontal position for draining through a faucet. A manual hand crank allows the drum to tilt up to 120°. Vertically raise the drums with a manual hand or foot pump operation.

Model DRUM-LRT-EC has a clamp style cradle which securely grips around the drum.

Model DRUM-LRT-ESJ features a steel jaw which securely grips the top lip of the drum.

| MODEL NUMBER | OVERALL SIZE (W x D x H) | *RAISED HEIGHT | UNIFORM CAPACITY | WEIGHT (POUND) |
|--------------|--------------------------|----------------|------------------|----------------|
| DRUM-LRT-EC | 40" x 44" x 82" | 59" | 550 lb. | 450 |
| DRUM-LRT-ESJ | 40" x 44" x 78" | 53" | 550 lb. | 450 |

*DRUM IN VERTICAL POSITION (floor to bottom of drum)

Portable Drum Lifter/Rotator/Transporters

Model DRUM-LRT features a hand pump to lift drums from ground level to a raised height of 62" to bottom of drum in vertical position. For use with 55 gallon steel and fiber drums 24" in diameter. A hand crank gear mechanism provides the controlled 360° rotation of the drum. A floor lock is standard to stabilize the unit in a fixed position. Horizontal dump height is 67" from floor to bottom of drum.

Model DRUM-LRT-II features pivoting straddle legs for access to drums on pallets. Legs will manually pivot and lock into place with locking pin.

Model DRUM-LRT-DC has a 12V DC battery powered lift operation and a manual hand crank gear mechanism rotation (on-board charger standard). Minor assembly required.

Model DRUM-LRT-DC-II features a 24V DC powered rotation mechanism, which provides 360° rotation of the drum. A 24V DC powered mechanism raises and lowers drums (on-board charger standard).

Model DRUM-LRT-DC-SCL has a fully powered drum scale with powered drive, lift, and rotation. High torque 24V DC drive. Ergonomic handle features safety enhanced emergency remote function and horn. Includes disc brake with automatic dead-man control. Two (2) 12V, 70-85 Ah lead acid batteries. Integral battery charger and level gauge. Scale head features automatic turn off and +/- 0.5 pound accuracy. Scale includes (6) six AA batteries and an AC adaptor.

| MODEL NUMBER | OVERALL SIZE (W x D x H) | *RAISED HEIGHT | UNIFORM CAPACITY | WEIGHT (POUND) |
|--|--|----------------|------------------|----------------|
| MANUAL OPERATION | | | | |
| DRUM-LRT | 33" x 52" x 85 ⁷ / ₁₆ " | 62" | 550 lb. | 519 |
| DRUM-LRT-II | 34" x 51 ¹ / ₂ " x 82 ⁵ / ₈ " | 62" | 550 lb. | 574 |
| DC POWER | | | | |
| DRUM-LRT-DC | 36 ¹ / ₄ " x 61" x 88" | 62" | 550 lb. | 789 |
| DRUM-LRT-DC-II | 36 ¹ / ₄ " x 61" x 88" | 62" | 550 lb. | 872 |
| AIR POWERED LIFT / MANUAL ROTATION | | | | |
| DRUM-LRT-AIR | 31" x 57" x 85" | 62" | 550 lb. | 667 |
| DC POWERED LIFT / DRIVE / ROTATE WITH SCALE | | | | |
| DRUM-LRT-DC-SCL | 61 ³ / ₁₆ " x 34 ⁵ / ₈ " x 85 ⁷ / ₁₆ " | 62" | 550 lb. | 859 |
| LRT OPTION | | | | |
| FDA-550-DRUM-LRT-PF** | DRUM ADAPTER OPTION (PLASTIC, FIBER) | | | 15 |

*DRUM IN VERTICAL POSITION (floor to bottom of drum)

** FACTORY INSTALLED

Manual Drum Carrier/Rotator

Here is an efficient, economical way to handle 55 gallon steel drums. Sturdy handle provides leverage for heavy lifting and easily locks drum in position 5" to 11" off floor. Drum rotates 360°. Rolls smoothly on two (2) 8" front wheels and one (1) 4" rear swivel caster. Not for use with drums on pallets.

| MODEL NUMBER | ACCEPTABLE DRUM TYPES | ROTATION METHOD | UNIFORM CAPACITY | WEIGHT (POUND) |
|---------------------|-----------------------|-----------------|------------------|----------------|
| DCR-110-55 | 55 GALLON STEEL | MANUAL | 800 lb. | 143 |
| DCR-110-55-SS | 55 GALLON STEEL | MANUAL | 800 lb. | 143 |
| DCR-110-55-FDA-800* | 55 GALLON FIBER | MANUAL | 800 lb. | 146 |
| DCR-110-55-FDC-30 | 30 GALLON STEEL | MANUAL | 800 lb. | 161 |

DRUM MUST BE FULL TO ROTATE AT RATED CAPACITY

*FOR USE WITH FIBER DRUMS

Economical Drum Transporters

Unique portable unit designed to lift and transport steel, plastic, and fiber drums with a top lip. Steel jaw securely grips the top lip of the drum. Available with either a manual mechanical ratchet, foot pump hydraulic, or DC powered lift mechanism. Straddle legs rotate for access to drums on pallets. Units roll on four (4) 8" x 2" phenolic swivel casters. The push handle folds down for easy access to ratchet and foot pump. All welded steel construction. Baked-in powder-coated toughness with a safety yellow finish. Optional scale weighs drums to an accuracy of +/-0.5 pounds. Optional scale includes six (6) AA batteries and an AC adaptor.

| MODEL NUMBER | DESCRIPTION | JAW SERVICE RANGE | UNIFORM CAPACITY | WEIGHT (POUND) |
|---------------------------|---|-------------------|------------------|----------------|
| DCR-880-M [Ⓢ] | HAND RATCHET | 31" to 47" | 880 lb. | 275 |
| DCR-880-H [Ⓢ] | FOOT PUMP | 31" to 49" | 1,500 lb. | 293 |
| DCR-880-H-HP [Ⓢ] | FOOT PUMP | 31" to 77½" | 880 lb. | 345 |
| DCR-880-H-DC | (1) 12V DC POWERED | 31" to 49" | 1,500 lb. | 446 |
| DCR-880-H-HP-DC | (1) 12V DC POWERED | 31" to 76" | 880 lb. | 506 |
| LDS-R3 | OPTIONAL LIFTING DRUM SADDLE ROLLER STYLE | | 1,000 lb. | 26 |
| LDS-B1 | OPTIONAL LIFTING DRUM SADDLE BELT STYLE | | 2,000 lb. | 21 |
| DCR-SCALE | OPTIONAL WEIGHT SCALE | | 1,500 lb. | 70 |



SECURE GRIP



model DCR-880-H



DCR-SCALE

model DCR-880-H-HP

Portable Drum Jacks

These Drum Jacks are the perfect solution to any of your drum transporting needs. Compact design allows for maximum maneuverability in restrictive areas. Steel construction.

Model DRUM-55-36 accepts 55 gallon steel and fiber drums with a top lip. The front rigid wheels are 6" x 1½", while the rear swivel casters are 3" x 1½".

Model DRUM-55FP has an adjustable beak design, which allows it to grab 30 and 55 gallon steel, plastic, or fiber drums. Drums can easily be placed on or removed from pallets, spill containers, and scales. Available with built-in scale feature, see below.

Model DRUM-55S has a unique grapple to hold 55 gallon steel drums securely into the steel saddle prior to lifting it vertically. The drum is held in this position during transit, enabling open drums to be handled without spillage.

Model DRUM-55-FSP has a single clamping mechanism, which automatically latches on the drum chime when being elevated or transported. The clamping mechanism is fully adjustable for shorter height drums.

Model DRUM-55-SCL-E can lift, transport, and weigh 30, 55, and 85 gallon steel, fiber, and plastic drums. Scale head features automatic turn-off and +/-0.5 lbs. accuracy. Scale is powered with AA batteries. AC adapter included.

Model DRUM-SCLG & DRUM-SCLF add a scale readout built into Drum Jack model DRUM-55FP. The scale allows the drum to be weighed and moved all with the same piece of equipment. The scale has a capacity of 1,000 lbs. with an accuracy of +/-0.5 lbs. 12V DC operation with batteries and charger included. Stainless steel scale components. NEMA 4 scale read-out housing swivels 360° for maximum viewing convenience.

| MODEL NUMBER | OVERALL SIZE (W x D) | LIFT HEIGHT | BEAK SERVICE RANGE | UNIFORM CAPACITY | WEIGHT (POUND) |
|-------------------------|---|----------------------------------|--|------------------|----------------|
| DRUM-55-36 [Ⓢ] | 30½" x 27 ¹³ / ₁₆ " | 15" | 33" to 52" | 500 lb. | 161 |
| DRUM-55FP | 41¾" x 41 ⁹ / ₁₆ " | 18" | 23 ⁷ / ₈ " to 57 ⁷ / ₈ " | 1,000 lb. | 379 |
| DRUM-55S [Ⓢ] | 28½" x 41 ³ / ₁₆ " | 5¼" | n/a | 660 lb. | 152 |
| DRUM-55-FSP | 39½" x 35" | 20" | 33" to 53" | 800 lb. | 375 |
| DRUM-55-SCL-E | 35" x 38 ⁵ / ₈ " | 23 ⁵ / ₈ " | -- | 900 lb. | 166 |
| DRUM-SCLG | DRUM-55FP W/ GENERAL READOUT SCALE | | | | 444 |
| DRUM-SCLF | DRUM-55FP W/ INTRINSICALLY SAFE READOUT SCALE | | | | 444 |



model DRUM-55-36



model DRUM-55FP



model DRUM-55FP SHOWN WITH SCALE, model DRUM-SCLF



model DRUM-55S



model DRUM-SCLF



model DRUM-SCLG

Stainless Steel Drum Lifter/Transporter

The Stainless steel hydraulic drum lifter is designed to allow the operator to load or unload drums on and off the corner of pallets. Straddle leg design allows the drum lifter to glide over standard pallets and grab most 30, 55, or 85 gallon steel and poly drums. Drums are raised and lowered easily using the foot pump. 304 grade all stainless steel construction. Ideal for wash-down, pharmaceutical, and clean room applications. Highly maneuverable on two (2) rigid and two (2) swivel with brake nylon wheels. Cannot be used with fiber drums.

| MODEL NUMBER | ACCEPTABLE DRUM TYPES | OVERALL SIZE (W x D x H) | BEAK SERVICE RANGE | UNIFORM CAPACITY | WEIGHT (POUND) |
|-------------------------|-----------------------|--------------------------|--------------------|------------------|----------------|
| DRUM-LT-SS [Ⓢ] | STEEL & POLY | 48" x 35" x 63" | 26" - 71" | 800 lb. | 345 |



model DRUM-LT-SS

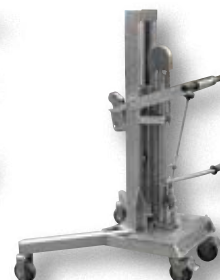

model DRUM-LT-SS



model PSDT

48 Hours
to Ship

Pallet Straddling Drum Truck

A single operator can engage, lift, and transport drums stored either on the center of pallets or the corner of containment skids. Works with 55 gallon steel drums. To engage a drum, the truck uses a spring-loaded jaw that securely grasps the rim of the drum. Two (2) rigid and two (2) swivel polyurethane wheels provide a high degree of maneuverability; each swivel wheel is equipped with a brake. Inside leg width adjusts 42" retracted to 47¹/₄" extended to straddle pallets. Steel construction with painted finish.

| MODEL NUMBER | OVERALL SIZE (W x D x H) | JAW HEIGHT | UNIFORM CAPACITY | WEIGHT (POUND) |
|-------------------|--|---|------------------|----------------|
| PSDT [Ⓢ] | 46 ³ / ₄ " x 32" x 44" | 34" to 45 ¹ / ₄ " | 550 lb. | 115 |



48 Hours
to Ship

model LPDT

YouTube

Manual Low Profile Hydraulic Drum Truck

Ideal for loading and unloading 55 gallon steel drums when no fork truck is available. This device allows a single operator to engage elevated drums as well as to transport and position drums. A spring-loaded clamp securely grasps the rim of a drum. To elevate the rim clamp up to 5 feet, the truck incorporates a foot-operated hydraulic pump. Unit rolls smoothly on two (2) rigid 2¹/₂" x 1¹/₂" front wheels and two (2) 3³/₁₆" x 1¹/₄" poly rear wheels. Truck is easy to assemble/disassemble for storage.

| MODEL NUMBER | OVERALL SIZE (W x D x H) | LOWERED HEIGHT | RAISED HEIGHT | UNIFORM CAPACITY | WEIGHT (POUND) |
|-------------------|--------------------------|----------------------------------|-----------------------------------|------------------|----------------|
| LPDT [Ⓢ] | 34" x 37" x 60" | 32 ⁷ / ₈ " | 64 ⁹ / ₁₆ " | 600 lb. | 185 |



48 Hours
to Ship

Ergonomic Drum Truck with Scale

The Ergonomic Drum Truck with Scale lifts, transports, and weighs 55 gallon steel drums. Utilizes an automatic grip assembly to effectively grab drums. Scale head features automatic turn-off and +/- .5 pound accuracy. Scale is powered with six (6) AA batteries. AC adapter included. Truck can lift uniform loads up to 500 pounds. Rolls smoothly on two (2) 8" x 2" poly-on-steel wheels and one (1) 5" x 1" phenolic swivel caster with lock. Lifting height is 7/8" per stroke. Maximum lifting height is 10¹/₄" to bottom of drum.

| MODEL NUMBER | OVERALL SIZE (W x L x H) | UNIFORM CAPACITY | WEIGHT (POUND) |
|--------------------------|--------------------------|------------------|----------------|
| DRUM-55-SCL [Ⓢ] | 31" x 43" x 41" | 500 lb. | 155 |



model DM-550

48 Hours
to Ship

Drum Lifter/Palletizer

This drum lifter/palletizer is an ideal addition to the maintenance and manufacturing facilities. The strong steel construction provides a durable approach to lifting and transporting drums. The upright design diminishes the bending and twisting that may occur when maneuvering heavy drums. For best use, place the unit so it straddles the drum. With the handle raised, place the lifting hooks under the rim of the drum in a secure position and lower the handle. By lowering the handle, the pressure of the down force will lift the drum and allow the user to transport it.

| MODEL NUMBER | OVERALL SIZE (W x D x H) | LIFT HEIGHT | UNIFORM CAPACITY | WEIGHT (POUND) |
|---------------------|--|-------------|------------------|----------------|
| DM-550 [Ⓢ] | 45 ¹ / ₁₆ " x 48" x 31 ¹ / ₂ " | 8" | 550 lb. | 225 |



model LO-DC-PU

48 Hours
to Ship

Lo-Profile Drum Caddies with Bung Wrench Handle

Reduce injuries caused by manually lifting and moving drums. Transport one (1) 55 or 30 gallon drum or two (2) 5 gallon pails with the Lo-Profile Drum Caddy. To use: align unit in front of drum, remove handle, and grip drum with the handle. Tip drum up, while guiding the caddy base under the drum. Re-attach handle and transport drum to desired location. Unit rolls easily on two (2) 6" rigid wheels and one (1) 3" swivel caster. The removable handle doubles as a bung nut wrench and seal remover. Cradle height is 1/2". Inside cradle diameter is 2³/₁₆". Steel construction. Yellow painted finish. US Patent Number 6682084.

| MODEL NUMBER | STRADDLE (W x D) | UNIFORM CAPACITY | WHEEL TYPE | WEIGHT (POUND) |
|-----------------------|--|------------------|----------------|----------------|
| LO-DC-MR [Ⓢ] | 24" x 16 ¹ / ₄ " | 1,000 lb. | MOLD-ON-RUBBER | 41 |
| LO-DC-CI [Ⓢ] | 24" x 16 ¹ / ₄ " | 1,200 lb. | CAST IRON | 47 |
| LO-DC-PU [Ⓢ] | 24" x 16 ¹ / ₄ " | 1,200 lb. | POLY-ON-STEEL | 46 |
| LO-DC-PH [Ⓢ] | 24" x 16 ¹ / ₄ " | 1,200 lb. | PHENOLIC | 46 |

Counter-Balanced Drum Lifters (Powered Lift & Power Drive) 12V DC POWER STANDARD

Ideal for confined areas, placing drums in cabinets, loading and unloading drums on/off pallets and scales. Transport one (1) 30 or one (1) 55 gallon steel, plastic, or fiber drums with ease. Two (2) 12V DC (lead acid batteries) drive and lift motor handles heavy-duty jobs. Ergonomic handle features easy-to-operate throttle with infinite adjustment of forward and reverse speeds, lift/lower controls, **proprietary safety-enhancing emergency reverse function**, and horn.

| MODEL NUMBER | DESCRIPTION | UNIFORM CAPACITY | SERVICE RANGE | WEIGHT (POUND) |
|--------------|-------------|------------------|---------------|----------------|
| S-CB-62-SDC | SINGLE GRIP | 1,000 lb. | 0" TO 62" | 1917 |
| S-CB-62-DDC | DUAL GRIP | 1,000 lb. | 0" TO 62" | 1967 |

model S-CB-62-SDC



Deluxe Tilt Back Drum Trucks

Move, tilt, and unload heavy 30 or 55 gallon steel and plastic drums with ease. A foot rest helps in loading and supports a loaded drum truck. Deluxe chime gripper for quick and easy drum transportation. Assembly required.

DBT-1000 rolls quietly on 10" x 2" mold-on-rubber wheels.

DBT-1000-PN features 15 $\frac{3}{4}$ " x 4" pneumatic wheels.

| MODEL NUMBER | OVERALL SIZE (W x D x H) | UNIFORM CAPACITY | WEIGHT (POUND) |
|--------------------------|---|------------------|----------------|
| DBT-1000 [Ⓢ] | 22 $\frac{1}{2}$ " x 24 $\frac{3}{8}$ " x 59" | 1,000 lb. | 91 |
| DBT-1000-PN [Ⓢ] | 32" x 27" x 63" | 1,000 lb. | 81 |

48 Hours
to ShipPNEUMATIC
model DBT-1000-PNMOLD-ON-RUBBER
model DBT-1000

Barrel/Drum Trucks

Barrel/Drum Trucks handle 30 and 55 gallon steel and fiber drums and barrels that are 24" to 48" high. Adjustable chime hook helps to secure the drum. Wheels measure 12" x 2" or 10" x 2" and are available in rubber-on-steel, poly-on-steel, or polyurethane. Uniform capacity is 800 pounds. DBT-1200 series features a kickstand for holding unit at a tilt.

| MODEL NUMBER | OVERALL SIZE (W x D x H) | WHEEL SIZE (DIA. x W) | WHEEL TYPE | WEIGHT (POUND) |
|-------------------------|--|-----------------------|-----------------|----------------|
| DBT-1200 [Ⓢ] | 29" x 20 $\frac{1}{4}$ " x 60" | 12" x 2" | RUBBER-ON-STEEL | 120 |
| DBT-1200-P [Ⓢ] | 29" x 20 $\frac{1}{4}$ " x 60" | 12" x 2" | POLY-ON-STEEL | 118 |
| DBT-RED [Ⓢ] | 24 $\frac{1}{4}$ " x 13 $\frac{3}{4}$ " x 60 $\frac{1}{4}$ " | 10" x 2" | POLYURETHANE | 48 |

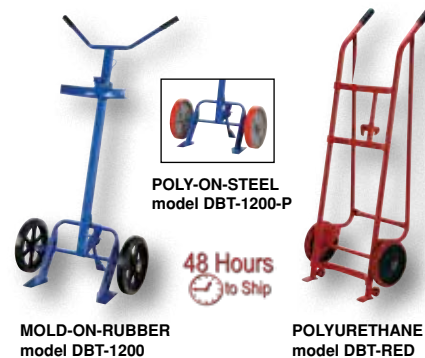
POLY-ON-STEEL
model DBT-1200-P48 Hours
to ShipMOLD-ON-RUBBER
model DBT-1200POLYURETHANE
model DBT-RED

Drum Trucks with Spring Assist

Hand trucks designed for moving 55 gallon steel and plastic drums weighing up to 1,000 pounds. Special design features spring mechanism for easy use. Spring allows for easier tilting of fully loaded drums. Removable hook bar includes built-in bung nut wrenches. Steel construction with a baked-in powder-coated toughness, yellow finish. 10" x 2 $\frac{1}{2}$ " wheels standard.

| MODEL NUMBER | ACCEPTABLE DRUM TYPE | OVERALL SIZE (W x D x H) | WHEEL TYPE | WEIGHT (POUND) |
|------------------------|----------------------|---|------------|----------------|
| DBT-SA-MR [Ⓢ] | STEEL | 23 $\frac{1}{2}$ " x 14 $\frac{5}{16}$ " x 60 $\frac{5}{8}$ " | MOR | 103 |
| DBT-SA-PO [Ⓢ] | STEEL | 23 $\frac{1}{2}$ " x 14 $\frac{5}{16}$ " x 60 $\frac{5}{8}$ " | POP | 110 |
| DBT-P-SA-MR | PLASTIC | 23 $\frac{1}{2}$ " x 22" x 60 $\frac{5}{8}$ " | MOR | 106 |
| DBT-P-SA-PO | PLASTIC | 23 $\frac{1}{2}$ " x 22" x 60 $\frac{5}{8}$ " | POP | 110 |

MOR = MOLD-ON-RUBBER / POP = POLY-ON-POLY

48 Hours
to ShipPOWDER
COATED
TOUGH

model DBT-P-SA-PO

Multi-Purpose Drum & Hand Trucks

Multi-purpose unit serves both 30 and 55 gallon steel and plastic drums. Works as a drum truck, drum cradle, and a hand truck. Extra-long handles give leverage for access to drums on pallets. Unit lies horizontally for use as a drum cradle to empty drum contents. Steel nose plate and drum tines are interchangeable. Features large 16" x 4" diameter wheels for use over rough terrain. Includes built-in bung nut wrench. Ships assembled. Drum is 11 $\frac{5}{8}$ " high when in cradle position.

| MODEL NUMBER | OVERALL SIZE (W x L x H) | UNIFORM CAPACITY | WHEEL TYPE | WEIGHT (POUND) |
|------------------------|--|------------------|-------------|----------------|
| DCHT-1 [Ⓢ] | 26 $\frac{3}{4}$ " x 28 $\frac{7}{8}$ " x 59 $\frac{13}{16}$ " | 500 lb. | PNEUMATIC | 121 |
| DCHT-1-FF [Ⓢ] | 26 $\frac{3}{4}$ " x 28 $\frac{7}{8}$ " x 59 $\frac{7}{8}$ " | 750 lb. | FOAM FILLED | 140 |

POWDER
COATED
TOUGH48 Hours
to Ship



model DBT-4R-PO



model RDBT-MR



model RDBT-PO



model DBT-SS



model DBT-SS-DLX



New

Four-Wheel Drum Trucks with Tilt-Back Spring Assist

Designed for moving 55 gallon steel or plastic drums. Features a spring mechanism, which allows for easier tilting of fully-loaded drums. Four-wheel design for easier drum transportation when tilted. Top loop handle allows for easier control when moving. Drum is secured to truck with an adjustable height drum hook bar. Removable drum hook bar includes built-in bung nut wrenches. Capacity is 1,000 pounds. Steel construction with a baked-in powder-coated toughness.

| MODEL NUMBER | ACCEPTABLE DRUM TYPE | MAIN WHEELS | STABILIZER CASTERS | WEIGHT (POUND) |
|--------------|----------------------|----------------|---------------------|----------------|
| DBT-4R-MR | STEEL | (2) 10" RUBBER | (2) 6" RIGID RUBBER | 110 |
| DBT-4R-PO | STEEL | (2) 10" POLY | (2) 6" RIGID POLY | 109 |
| DBT-P-4R-MR | PLASTIC | (2) 10" RUBBER | (2) 6" RIGID RUBBER | 109 |
| DBT-P-4R-PO | PLASTIC | (2) 10" POLY | (2) 6" RIGID POLY | 109 |
| DBT-4RS-MR | STEEL | (2) 10" RUBBER | (2) 3" SWIVEL POLY | 111 |
| DBT-4RS-PO | STEEL | (2) 10" POLY | (2) 3" SWIVEL POLY | 111 |
| DBT-P-4RS-MR | PLASTIC | (2) 10" RUBBER | (2) 3" SWIVEL POLY | 110 |
| DBT-P-4RS-PO | PLASTIC | (2) 10" POLY | (2) 3" SWIVEL POLY | 110 |

Multi-Purpose Drum Trucks/Cradles

One of the most versatile drum trucks in the industry. This innovative product allows the operator to easily tip back the truck in order to transport drums ergonomically on four (4) wheels. Unit doubles as a drum cradle for storage and dispensing all in one. Top angle is 3° when used as a Drum Cradle. This unique design also allows the operator to place drums and retrieve off of a pallet. Accommodates 55 gallon steel, plastic, or fiber drums. Rolls smoothly on two (2) 10" x 2½" (wheel types see below), two (2) 6" x 2" poly-on-poly wheels, and two (2) 3" x 1¼" poly-on-poly swivel casters. Standard with a wheeled undercarriage that positions the drum horizontally for drainage or storage. The drain height is 12¹³/₁₆" high in the cradle position. An integral self-storing bung wrench is standard. This attractive feature not only opens numerous drums, but helps to keep the drum snug on the truck. Baked-in powder-coated toughness. Optional drip pan with brackets available.

| MODEL NUMBER | OVERALL SIZE (W x L x H) | UNIFORM CAPACITY | WHEEL TYPE | WEIGHT (POUND) |
|--------------|---|------------------|----------------|----------------|
| RDBT-MR | 23½" x 20 ¹ / ₁₆ " x 60 ⁵ / ₈ " | 1,000 lb. | MOLD-ON-RUBBER | 140 |
| RDBT-SS | 23½" x 20 ¹ / ₁₆ " x 60 ⁵ / ₈ " | 1,000 lb. | SEMI-STEEL | 158 |
| RDBT-PO | 23½" x 20 ¹ / ₁₆ " x 60 ⁵ / ₈ " | 1,000 lb. | POLY-ON-POLY | 148 |
| RDBT-PAN | OPTIONAL DRIP PAN (8¼"W x 11"L x 4"H) | | | 3 |

Stainless Steel Drum Trucks

model DBT-SS, Tilt and lower drums to a horizontal position for dispensing. Grips all types of steel 30, 55, & 85 gallon drums and most rimmed plastic and fiber drums. Robust, non-corrosive design - 304 all stainless steel construction. Adjustable chime hook helps to secure the drum. Kickstand for holding the unit in stand-up position. 4-wheel design offers exceptional maneuverability through tight areas. 4½" ground clearance with four (4) 8" x 2" nylon wheels.

model DBT-SS-DLX, Easily, efficiently, and safely lift, move, and maneuver a wide range of steel and plastic drums. Automatic grip can be adjusted manually up and down to suit different heights. Robust design - 304 all stainless steel construction. 50% less input force is required to lift a 1,000 lb drum compared to standard drum trucks. To operate, simply push the truck to drum and attach the automatic grip to the drum rim. Rolls simply and smoothly on two (2) 8" x 2" nylon wheels.

| MODEL NUMBER | ACCEPTABLE DRUM TYPE | OVERALL SIZE (W x D x H) | UNIFORM CAPACITY | WEIGHT (POUND) |
|--------------|-----------------------|---|------------------|----------------|
| DBT-SS | STEEL, PLASTIC, FIBER | 22¼" x 51 ³ / ₁₆ " x 37½" | 1000 lb. | 70 |
| DBT-SS-DLX | STEEL & PLASTIC | 31 ¹ / ₈ " x 20" x 55 ¹ / ₈ " | 1000 lb. | 95 |

Revolving Drum Carts

Designed to rotate a 55 gallon steel drum from the vertical position to the horizontal position so their contents may be emptied. Equipped with rollers for mixing. Includes a built-in drip pan to provide a clean, safe work floor. Rolls on two (2) 3" swivel casters and two (2) 5" rigid casters. Simple one-person operation. Steel construction. Baked-in powder-coated toughness.

| MODEL NUMBER | NUMBER OF ROLLERS | OVERALL SIZE (W x L x H) | UNIFORM CAPACITY | WEIGHT (POUND) |
|-------------------------|-------------------|--|------------------|----------------|
| RDC-100 [Ⓢ] | 4 DUAL ROLLERS | 18 ⁷ / ₈ " x 66 ³ / ₄ " x 26 ³ / ₄ " | 600 lb. | 46 |
| RDC-100-10 [Ⓢ] | 4 DUAL ROLLERS | 18 ⁷ / ₈ " x 66 ³ / ₄ " x 26 ³ / ₄ " | 1,000 lb. | 52 |



model RDC-100-10

48 Hours
to Ship

Economy Rotating Drum Carts

Easy to operate. Includes two (2) rigid and two (2) swivel casters. Handle includes bung nut wrench and a built-in drum tipper to assist with liquid drainage. Rugged steel construction with painted finish. Assembly required.

| MODEL NUMBER | UNIFORM CAPACITY | WHEEL SIZE | WHEEL TYPE | WEIGHT (POUND) |
|--------------------------|--|------------|--------------|----------------|
| RDC-60-NC [Ⓢ] | 800 lb. | -- | NONE | 46 |
| RDC-60-5-PU [Ⓢ] | 800 lb. | 5" | POLYURETHANE | 53 |
| RDC-60-5-PO [Ⓢ] | 800 lb. | 5" | POLYOLEFIN | 46 |
| RDC-60-5-SS [Ⓢ] | 800 lb. | 5" | STEEL | 60 |
| RDC-60-HDL [Ⓢ] | REPLACEMENT HANDLE | | | 6 |
| RDC-60-DPN [Ⓢ] | OPTIONAL DRIP PAN WITH BRACKETS (9"W x 12"L x 7-5/32"H) | | | 3 |

48 Hours
to Ship

model RDC-60-NC

model RDC-60-5-PO
shown with JDFT Drum
Faucet (see page 317)model
RDC-60-HDLmodel
RDC-60-5-PU

Deluxe Rotating Drum Carts

Practical design is easy to operate and features a capacity of 1,000 pounds. Includes two (2) rigid and two (2) swivel casters. Two (2) retractable wooden handles included for easy operation. Steel stops enable operator to hold drum during tipping operation and includes a built-in bung nut wrench as a bonus. Rugged steel construction with painted finish. Assembly required.

| MODEL NUMBER | UNIFORM CAPACITY | WHEEL SIZE | WHEEL TYPE | WEIGHT (POUND) |
|---------------------------|--|------------|---------------|----------------|
| RDC-1000-5PU [Ⓢ] | 1,000 lb. | 5" | POLY-ON-STEEL | 85 |
| RDC-1000-5PO [Ⓢ] | 1,000 lb. | 5" | POLYOLEFIN | 85 |
| RDC-1000-5SS [Ⓢ] | 1,000 lb. | 5" | STEEL | 85 |
| RDC-1000-DPN [Ⓢ] | OPTIONAL DRIP PAN WITH BRACKETS (8 ¹ / ₄ "W x 11"L x 4"H) | | | 2 |

model
RDC-1000-5POmodel
RDC-1000-DPN

Dispensing Containment Cart

Drum handling, dispensing, and containment all in one unit. Unlike alternative products, the open containment sump does not require spills to flow inside the double walls to meet EPA regulations -- easy to clean; eliminates residue concerns as related to compatibility. Can be used with 55 or 30 gallon drums, nylon strap keeps drums secure. Large 10" wheels roll easily over shop and factory floors.

| MODEL NUMBER | OVERALL SIZE (W x D x H) | SUMP CAPACITY | UNIFORM CAPACITY | WEIGHT (POUND) |
|--------------|--|---------------|------------------|----------------|
| DHDC-66 | 32" x 72 ¹ / ₄ " x 27" | 66 GALLONS | 600 lb. | 118 |



model DHDC-66



48 Hours
to Ship

model HSRB-4

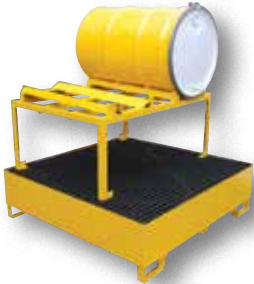

model HSRB-YL-2



model VSRB-IN-4

48 Hours
to Ship



model STP-4

CA Residents see
WARNING A, Pg. 459



model VSRB-WS-4
shown with model VSRB-SAU

Horizontal Steel Retention Basins

Dispense or store 55 gallon steel drums with these non-flammable heavy-duty Horizontal Steel Retention Basins. These units are constructed of steel to resist extreme heat environments. The rugged steel construction provides durability and repairability. Portability is made easy with the built in fork pockets. The built-in horizontal drum cradles are sloped.

| MODEL NUMBER | DRUM CAPACITY | OVERALL SIZE (W x L x H) | UNIFORM CAPACITY | COLOR | WEIGHT (POUND) |
|--------------------------|---------------|--------------------------|------------------|--------|----------------|
| HSRB-YL-1 [⊕] * | 1 | 27" x 49" x 32" | 1,200 lb. | YELLOW | 195 |
| HSRB-YL-2 [⊕] * | 2 | 49" x 49" x 32" | 1,200 lb. | YELLOW | 325 |
| HSRB-4* | 4 | 61" x 52" x 48" | 2,400 lb. | BLUE | 310 |
| HSRB-1** | 1 | 32" x 52" x 18" | 600 lb. | BLUE | 210 |
| HSRB-2** | 2 | 61" x 52" x 18" | 1,200 lb. | BLUE | 235 |

*MEETS EPA 40 CPR - 264.175 & UFC 8003.1.3.4

**MEETS RCRA, Uniform Fire Code (UFC 8003), EPA 40CPR - 264.175 & UFC 8003.1.3.4

Vertical Steel Retention Basins

Store 55 gallon steel drums in the vertical position with these new non-flammable heavy-duty Drum Basins. These basins are constructed of steel to resist extreme heat environments. The rugged steel construction provides durability and repairability. Four way fork entry. Basins are stackable when empty to provide more space in a warehouse or storage area.

| MODEL NUMBER | DRUM CAPACITY | OVERALL SIZE (W x L x H) | UNIFORM CAPACITY | COLOR | WEIGHT (POUND) |
|------------------------|---------------|--------------------------|------------------|--------|----------------|
| VSRB-1 | 1 | 34" x 34" x 18" | 600 lb. | BLUE | 195 |
| VSRB-YL-2 [⊕] | 2 | 27" x 49" x 14" | 1,200 lb. | YELLOW | 153 |
| VSRB-YL-4 [⊕] | 4 | 49" x 49" x 14" | 2,400 lb. | YELLOW | 211 |
| VSRB-IN-4 | 4 | 107" x 34" x 10" | 2,400 lb. | BLUE | 380 |
| VSRB-2* | 2 | 54" x 34" x 14" | 1,200 lb. | BLUE | 205 |
| VSRB-4* | 4 | 54" x 50" x 10" | 2,400 lb. | BLUE | 270 |

*MEETS EPA 40 CPR - 264.175 & UFC 8003.1.3.4

Stackable Transport Pallets with Side Rails

Most spills occur when transporting chemicals. Safely and securely move your chemicals with our Transport Pallets. Welded all steel construction with a durable finish. Grating is easily removable for sump cleanup. 66 gallon sump capacity. Each unit is individually tested after being welded and before paint for leaks with a low viscous die penetrant test. Four-way forklift access. Meets EPA 40 CPR-264.175 and UFC 8003.1.3.4 requirements.

| MODEL NUMBER | DRUM CAPACITY | OVERALL SIZE (W x L x H) | UNIFORM CAPACITY | COLOR | WEIGHT (POUND) |
|--------------|---------------|--------------------------|------------------|-------|----------------|
| STP-2 | 2 | 54" x 34" x 55" | 1,200 lb. | BLUE | 310 |
| STP-4 | 4 | 55" x 50" x 54" | 2,400 lb. | BLUE | 385 |
| STP-BAR | SECURITY BAR | 54" | -- | -- | 4 |

Vertical Steel Retention Basins with Separation Walls

These retention basins with splash walls protect and provide additional separation of your chemicals, while transporting drums. Durability of all steel construction insures years of use in even the harshest industrial conditions. Arms snap into place on uprights to provide optional shelf system available for storing smaller drums or other containers. Arms measures 23"W x 18½"D. Enamel blue finish is standard; galvanized is available, contact factory.

| MODEL NUMBER | DRUM CAPACITY | OVERALL SIZE (D x L x H) | UNIFORM CAPACITY | COLOR | WEIGHT (POUND) |
|--------------|---------------|------------------------------|------------------|-------|----------------|
| VSRB-WS-2 | 2 DRUMS | 34" x 54" x 55" | 1,200 lb. | BLUE | 320 |
| VSRB-WS-4 | 4 DRUMS | 50" x 55" x 53" | 2,400 lb. | BLUE | 410 |
| VSRB-SAU | | 1 PAIR SHELF ARMS & UPRIGHTS | | | 5 |
| VSRB-SA | | 1 PAIR SHELF ARMS | | | 5 |

Steel Retention Basin Carts

Transfer 55 gallon steel drums from area to area and then safely dispense the drums with these nonflammable Retention Basin Carts. These units are constructed of steel to resist extreme heat environments. Portability is made easy with the two (2) rigid and two (2) swivel with lock polyurethane casters. A push handle is located at one end for easy maneuverability. Removable grating is standard. Model SRBC-HR-YL features a stand which measures 20"W x 32"L x 18"H.

| MODEL NUMBER | DRUM CAPACITY | OVERALL SIZE (W x L x H) | UNIFORM CAPACITY | SUMP CAPACITY | WEIGHT (POUND) |
|--------------------------------|---------------|--------------------------|------------------|---------------|----------------|
| VERTICAL DRUM STORAGE | | | | | |
| SRBC-1* | 1 | 34" x 34" x 40" | 600 lb. | 66 GALLON | 300 |
| SRBC-2* | 2 | 54" x 34" x 40" | 1,200 lb. | 66 GALLON | 340 |
| SRBC-YL-2 [Ⓢ] | 2 | 31" x 52¼" x 42" | 1,200 lb. | 43 GALLON | 274 |
| HORIZONTAL DRUM STORAGE | | | | | |
| SRBC-HR-2* | 2 | 54" x 34" x 40" | 1,200 lb. | 66 GALLON | 880 |
| SRBC-HR-YL [Ⓢ] | 1 | 52" x 30" x 60" | 1,200 lb. | 51 GALLON | 193 |

MEETS EPA 40 CFR - 264.175 & UFC 8003.1.3.4

*BLUE IN COLOR



model SRBC-YL-2

Utility Trays

Keep messy drips and spills off warehouse and factory floors. Heavy duty polyethylene construction will not rust or corrode. Ribbed bottoms keep cans, pails, and other containers elevated above any spills or leaks. Stackable for easy storage, when not in use.

| MODEL NUMBER | INSIDE (W x D x H) | OUTSIDE (W x D x H) | SUMP CAPACITY | WEIGHT (POUND) |
|--------------|--------------------|---------------------|---------------|----------------|
| UT-TRAY-2436 | 24" x 36" x 4¾" | 28¼" x 40¼" x 5" | 18 GALLON | 8 |
| UT-TRAY-2448 | 24" x 48" x 4¾" | 28¼" x 52¼" x 5" | 24 GALLON | 11 |
| UT-TRAY-3048 | 30" x 48" x 4¾" | 33¾" x 52" x 5" | 30 GALLON | 16 |
| UT-TRAY-4048 | 40" x 48" x 3½" | 44" x 52" x 4" | 30 GALLON | 18 |



model DSHRT-2

Drum Storage Hard Top Containers

Store hazardous drums safely outdoors with pumps and funnels in place. Tall 23¾" head space easily accommodates rotary drum pumps and large conical funnels. Low profile (8¾") containment pallet positions drum-top funnels at safe, convenient level to pour hazardous wastes. Roll-top covers can be easily lifted from waist height to access drum tops -- no need to reach near ground level. Unit can be lifted with a fork truck and locked for security purposes. All polyethylene construction will not rust or corrode.

| MODEL NUMBER | OVERALL SIZE (W x D x H) | SUMP CAPACITY | DRUM CAPACITY | UNIFORM CAPACITY | WEIGHT (POUND) |
|--------------|--------------------------|---------------|---------------|------------------|----------------|
| DSHRT-2 | 67¼" x 41¼" x 74½" | 66 GALLON | 2 | 4,500 lb. | 260 |
| DSHRT-4 | 64½" x 62" x 79" | 75 GALLON | 4 | 9,000 lb. | 440 |



model DSHRT-2

Ultra-Spill Pallets & Decks

Ultra-Spill Decks, *series VLPUT*, function like other spill decks, but disassemble into smaller components when not in use, saving valuable storage space and shipping costs. Decks can be connected with optional bulkhead fittings to create a custom spill containment area. Polyethylene grating is easily removed for quick clean-up.

Ultra-Spill Pallets, *series DR* combine high-strength and low-profile features, while meeting EPA Container Storage Regulations. 100% polyethylene construction is compatible with a broad range of chemicals, including acids and corrosives. Removable grates feature a non-slip surface.

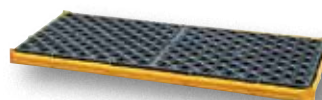

model VLPUT-2448



model DR-1-UT



model DR-2-UT

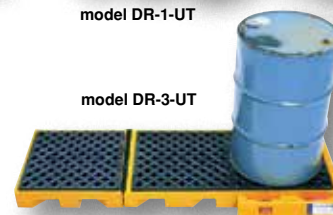

model DR-3-UT

| MODEL NUMBER | DRUMS CAPACITY | OVERALL SIZE (W x L x H) | SUMP CAPACITY | UNIFORM CAPACITY | FORK POCKET (W x H) | FORK POCKET CENTERS | WEIGHT (POUND) |
|--------------|----------------------------------|--------------------------|---------------|------------------|---------------------|---------------------|----------------|
| VLPUT-2448 | 2 | 24" x 48" x 2½" | 11 GALLON | 3,000 lb. | -- | -- | 22 |
| VLPUT-4848 | 4 | 48" x 48" x 2½" | 22 GALLON | 6,000 lb. | -- | -- | 44 |
| VLPUT-BF | BULKHEAD FITTING FOR VLPUT DECKS | | | | | | 1 |
| DR-1-UT | 1 | 40" x 40" x 12" | 62 GALLON | 800 lb. | 7" x 4½" | 15" | 51 |
| DR-2-UT | 2 | 53" x 29" x 16½" | 66 GALLON | 3,000 lb. | 10½" x 4½" | 17½" | 63 |
| DR-3-UT | 3 | 77⅞" x 28⅞" x 5¾" | 99 GALLON | 4,500 lb. | -- | -- | 67 |
| DR-4-UT | 4 | 53" x 53" x 11¾" | 66 GALLON | 6,000 lb. | 14½" x 4" | 21½" | 90 |

model DR-4-UT





model IBC-330



Intermediate Bulk Containers

Space-saving storage containers are great for multi-trip applications. Designed for storage of both hazardous and nonhazardous contents. Easy to fill, stack, and load. Steel cage is hot dipped galvanized material consistent with Food Code requirements for use in non-direct food contact environments. Pallet base is made from both steel and plastic. Includes inner storage tank made from white plastic with UV-blocking additive. Includes 2" butterfly valve with a durable, synthetic fluorocarbon rubber gasket. Top fill cap is 6" diameter with 2" bung. Complete unit is UN approved.

Protect IBC spills with our **IBC Containment Pallets, series ISCP**. All polyethylene construction makes the unit resistant to chemicals and will not rust. Fork pockets for easy lifting and positioning. Meets SPCC and EPA Container Storage Regulation 40 CFR 264.175.



model ISCP-1



model ISCP-DP

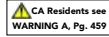

| MODEL NUMBER | OVERALL SIZE (W x L x H) | UNIFORM CAPACITY | VOLUME CAPACITY | WEIGHT (POUND) | |
|---|--|----------------------|------------------|----------------------|----------------|
| IBC-275 | 40" x 48" x 46¼" | 2,500 lb. | 275 GALLON | 130 | |
| IBC-330 | 40" x 48" x 53" | 3,000 lb. | 330 GALLON | 140 | |
| INTERMEDIATE BULK CRATE SPILL CONTAINMENT PALLETS | | | | | |
| MODEL NUMBER | OVERALL SIZE (W x L x H) | CONTAINMENT CAPACITY | UNIFORM CAPACITY | FORK POCKETS (W x H) | WEIGHT (POUND) |
| ISCP-1 | 62" x 62" x 28" | 360 GAL. | 8,500 lb. | 7¼" x 4" | 325 |
| ISCP-2 | 62" x 124½" x 22" | 535 GAL. | 8,000 lb. | 7¼" x 4¾" | 452 |
| ISCS-1* | 50⅞" x 53" x 37¼" | 400 GAL. | 2,500 lb. | 7½" x 2½" | 1018 |
| ISCP-DP | OPTIONAL DRIP PAN (19½"W x 16"L x 14½"H) | | | | 12 |

*STEEL CONSTRUCTION



model IBC-TLT

Intermediate Bulk Container Tilting Cart

The Intermediate Bulk Container Tilting Cart is designed of a sturdy steel construction which, provides a secure tilting of containers for complete draining. To use, simply place the container on the cart. When the container is in the secure position, start the draining process. As the fluid flows from the container, the rear of the cart will rise up to 5 degrees creating an angle for a better release of fluids. The cart rolls on casters for smooth transition from workstation to workstation.

| MODEL NUMBER | OVERALL SIZE (W x L x H) | LOWERED/RAISED HEIGHT | UNIFORM CAPACITY | WEIGHT (POUND) |
|--------------|---|--|------------------|----------------|
| IBC-TLT | 41 ³ / ₁₆ " x 53 ³ / ₈ " x 35 ¹³ / ₁₆ " | 12 ³ / ₄ " to 16 ¹ / ₂ " | 4,400 lb. | 261 |

Intermediate Bulk Container Heaters

An adjustable wrap around tote tank heater is a great asset to an assortment of container sizes. With the simple modifiable straps, the heater can be applied easily to an existing unit. An adjustable thermometer with a built in max temperature reset is also included for both precise heat allocation and overall safety. To use, easily maneuver the unit around the container and adjust the straps accordingly until secure.

Model IBC-HEAT-TOP is available to protect integral heat from leaving from unprotected areas.



model IBC-HEAT-330

| MODEL NUMBER | TANK HEIGHT | TANK (W x L) | VOLTAGE | WEIGHT (POUND) |
|--------------|--------------------------------|--------------|---------|----------------|
| IBC-HEAT-275 | 42" | 40" - 48" | 120V | 40 |
| IBC-HEAT-330 | 48" | 40" - 48" | 120V | 58 |
| IBC-HEAT-TOP | INSULATED TOP FOR ABOVE MODELS | | | 11 |

Overpack Containers

Overpack Containers are a great asset when maintaining and moving waste materials. The unit is constructed of low density polyethylene for strength and durability. Suitable for use with 55 gallon steel or plastic drums. The containment can be moved by utilizing a fork truck or other lifting devices. Works with DRUM-ST, DRUM-HD, DRUM-X-H, and DRUM-X-C.

Optional Drum Containment Cover available separately. To attach simply place cover onto the drum containment and snap-on until latched. Units can be stacked/nested for storage and shipping.

| MODEL NUMBER | DESCRIPTION | OVERALL SIZE (W x L x H) | SUMP CAPACITY | UNIFORM CAPACITY | WEIGHT (POUND) |
|----------------------------|-------------------|--------------------------|---------------|------------------|----------------|
| SCC-65-YL [®] | CONTAINER, YELLOW | 36¼" x 36¼" x 29½" | 65 GALLON | 800 lb. | 32 |
| SCC-65-OR [®] | CONTAINER, ORANGE | 36¼" x 36¼" x 29½" | 65 GALLON | 800 lb. | 32 |
| SCC-65-CVR-YL [®] | COVER, YELLOW | 37" x 37" x 11⅝" | -- | -- | 15 |
| SCC-65-CVR-OR [®] | COVER, ORANGE | 37" x 37" x 11⅝" | -- | -- | 15 |



OVERPACK CONTAINER
model SCC-65-YL



CONTAINER COVER
model SCC-65-CVR-YL



Fuel Tank Containment with Drain

Complete containment for 275 & 550 gallon oval tanks, indoors or outdoors! Eliminate costly spills while storing fuels, oils, and other hazardous liquids. Rugged, all polyethylene construction will not rust or corrode. Optional Pull Over Cover available.

| MODEL NUMBER | OVERALL SIZE (W x D x H) | INSIDE TOP (W x D) | INSIDE BOTTOM (W x D) | WEIGHT (POUND) |
|--------------|---|--------------------|-----------------------|----------------|
| OTC-275 | 84½" x 43¾" x 29" | 80" x 39" | 73" x 31" | 90 |
| OTC-550 | 87" x 60" x 33" | 82" x 54" | 75¾" x 47¾" | 108 |
| OTC-CVR275 | OPTIONAL PULL OVER COVER FOR OTC-275 ONLY | | | 8 |



model OTC-275 with
Optional Pull Over Cover



Drum Grab

Designed exclusively for lifting closed and open-head 55 gallon steel drums with a secured lid installed. *Not for use on open-head drums without a lid.* This product works on select 55 gallon plastic and fiber drums with a top lip strong enough to hold the weight of the drum. Designed for quick and easy one person operation, with drum in a vertical position. The narrow profile design is great for picking up drums packed close together. The three-arm ductile-iron design offers maximum strength and simplicity allowing the centering of the drum under the lifter. The polyurethane "spring" loop keeps the lifter securely engaged to the drum, which is especially beneficial when using the lifter in a rough environment including swinging, bouncing, and incidental collisions. Unit must be manually disengaged from the drum when finished with use.

| MODEL NUMBER | ACCEPTABLE DRUM TYPE | UNIFORM CAPACITY | WEIGHT (POUND) |
|------------------------|--------------------------------|------------------|----------------|
| DRUM-GRAB [®] | STEEL CLOSED & OPEN-HEAD W/LID | 2,200 lb. | 20 |



Multi-Purpose Overhead Drum Lifters/Wrenches

Simple three-arm design for use with closed head 30 and 55 gallon steel, plastic, and fiber drums with a top lip. Each removable arm also functions as a wrench for use on drum plugs, faucets, and rim ring bolts. Mechanical operation. Requires assistance from an overhead lifting device. Baked-in powder-coated toughness. Steel construction.

Model PDL-800-M-BR features a bronze, spark resistant alloy.



model PDL-800-M



model PDL-800-M-BR

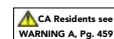

| MODEL NUMBER | CONSTRUCTION | UNIFORM CAPACITY | WEIGHT (POUND) |
|---------------------------|--------------|------------------|----------------|
| PDL-800-M [®] | STEEL | 800 lb. | 20 |
| PDL-800-M-BR [®] | BRONZE ALLOY | 800 lb. | 18 |

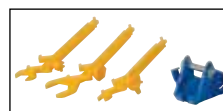

48 Hours
to Ship

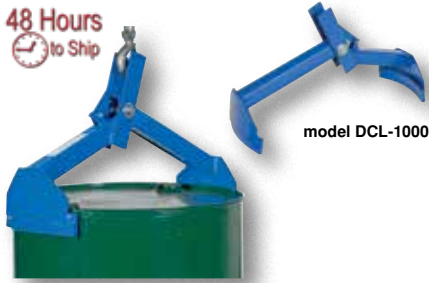

model DCL-1000

Drum Clutchers

Allows for easy lifting and transporting of steel drums with an overhead lifting chain or hoist. Drum Clutchers are ideal for placing drums in secondary containment and salvage drums. Designed for steel drums with a top lip or chime. Not for use with open head drums.

| MODEL NUMBER | ACCEPTABLE DRUM SIZE | UNIFORM CAPACITY | WEIGHT (POUND) |
|--------------|----------------------|------------------|----------------|
| DCL-550 | 30 GALLON | 550 lb. | 24 |
| DCL-1000® | 55 GALLON | 1,000 lb. | 26 |



model VDL-22.5

48 Hours
to Ship

Vertical Drum Lifter

The Vertical Drum Lifter provides easy lifting and transporting of drums. Solid steel construction. To use, simply lower unit onto the drum and as the lifter is elevated the positive gripping pads secure the drum. When the drum is lowered to the ground, the carriage drops down, automatically locking the drum lifter in an open position, ready for another drum. Use on 55 gallon steel drums with a top lip or chime. Not for use with open head drums.

| MODEL NUMBER | ACCEPTABLE DRUM SIZE | UNIFORM CAPACITY | WEIGHT (POUND) |
|--------------|----------------------|------------------|----------------|
| VDL-22.5® | 55 GALLON | 1,000 lb. | 48 |



model CHDL-2025

48 Hours
to Ship

Crane/Hoist Drum Lifters

Crane/Hoist Drum Lifters have an automatic mechanical operation. Great for positioning drums in and out of overpacks. Steel construction with spring loaded arms for safety. Accommodates steel, plastic, or fiber drums. Overall dimensions are 16" W x 9½" L x 21½" H. Drums weighing over 500 pounds must have top lid secured before lifting.

| MODEL NUMBER | ACCOMMODATES DRUM DIAMETER | UNIFORM CAPACITY | WEIGHT (POUND) |
|--------------|----------------------------|------------------|----------------|
| CHDL-1620 | 16" TO 20" | 1,000 lb. | 18 |
| CHDL-2025® | 20" TO 25" | 1,000 lb. | 18 |



model DL-1000-SS

Stainless Steel Drum Lifter

A stainless steel, adjustable, 3-point drum lifter for lifting, transporting, and stowing 30 and 55 gallon steel or plastic drums. Designed with a 3-point drum contact with stabilizing arms, which reduces damage to the drum and automatically engages the drum rim when lowered. Ideal vertical drum lifting tool which can be used with an overhead crane, hoist, or forklift attachment. Strong and durable - 304 grade full stainless steel construction. Designed for quick and easy one person operation.

| MODEL NUMBER | ACCEPTABLE DRUM SIZE | UNIFORM CAPACITY | WEIGHT (POUND) |
|--------------|----------------------|------------------|----------------|
| DL-1000-SS® | 30 & 55 GALLON | 1,000 lb. | 16 |



48 Hours
to Ship

Stainless Steel Vertical Drum Lifter

The stainless steel 2-point drum lifter is great for lifting 30 and 55 gallon steel or plastic drums. It makes transportation of open or closed drums easy. Allows quick, gentle loading into over packs and keeps drums upright during lifting to reduce spilling. Works perfectly with a hoist or an overhead crane. Full stainless steel construction.

| MODEL NUMBER | ACCEPTABLE DRUM SIZE | UNIFORM CAPACITY | WEIGHT (POUND) |
|--------------------------|----------------------|------------------|----------------|
| VDL-1000-SS [®] | 30 & 55 GALLON | 1,000 lb. | 28 |



model VDL-1000-SS

Vertical Drum Clamp

Easily moves and handles open or closed head loaded 30 and 55 gallon steel, plastic, and fiber drums. Allows quick, gentle loading into overpacks and keeps drums upright during lift, reducing spills and injuries. Designed exclusively for lifting closed and open-head drums with a secured lid installed.

| MODEL NUMBER | ACCEPTABLE DRUM TYPES | UNIFORM CAPACITY | WEIGHT (POUND) |
|-----------------------|-----------------------|------------------|----------------|
| VDC-1000 [®] | STEEL, PLASTIC, FIBER | 1,000 lb. | 11 |

48 Hours
to Ship



model VDC-1000

Overhead Drum Lifter

This Overhead Drum Lifter is designed for lifting drums with an overhead crane or similar lifting device. Integral fork pockets are also included for transportation with forklift. Steel saddle is designed for use with 30 and 55 gallon steel, plastic, and fiber drums with a maximum diameter of 24 $\frac{3}{8}$ ". Unit comes complete with a ratchet strap for securely holding the drum in place. With a non-tilting style, this lifter is made for straight vertical lifting only. Features a durable yellow baked-in powder-coated toughness.

| MODEL NUMBER | ACCEPTABLE DRUM TYPES | UNIFORM CAPACITY | WEIGHT (POUND) |
|-----------------------|-------------------------------|------------------|----------------|
| DRUM-LUG [®] | PLASTIC, STEEL, & FIBER DRUMS | 1,000 lb. | 151 |



POWDER
COATED
TOUGH[®]

model DRUM-LUG

Heavy Duty Vertical Drum Lifter

The Heavy Duty Vertical Drum Lifter makes it virtually impossible for a drum to break loose. Designed to lift 55 gallon open (with lid installed and secured) and closed head steel drums in the vertical position. An industrial ratchet load-binder is used to clamp the unit to the top of the drum. Uniform capacity is 1,500 pounds. Lifter features integral fork pockets for use with fork truck forks/tines as well as lifting points for attachment of slings or chains. A safety restraint is included to secure the drum lifter to a carriage when being used with a fork truck.



model HDDL-55



| MODEL NUMBER | ACCEPTABLE DRUM TYPE | UNIFORM CAPACITY | WEIGHT (POUND) |
|--------------|--------------------------------|------------------|----------------|
| HDDL-55 | OPEN & CLOSED HEAD STEEL DRUMS | 1,500 lb. | 91 |



model CDL-2000

Chain Drum Lifter

Designed for drum lifting and transporting with an overhead lifting device. Constructed of grade 80 chain for OSHA & ANSI compliance. Easy to use design. Drum clamps include spring-loaded latch for positive drum grip. For use with closed head steel, plastic, and fiber 30 and 55 gallon drums with a top lip.

| MODEL NUMBER | ACCEPTABLE DRUM TYPES | UNIFORM CAPACITY | WEIGHT (POUND) |
|--------------|-------------------------------|------------------|----------------|
| CDL-2000 | PLASTIC, STEEL, & FIBER DRUMS | 2,000 lb. | 9 |



model FDT-22

model DL-31

Drum Lifters

Model FDT-22 can be used to lift both 30 and 55 gallon steel drums with either an overhead chain or hoist. This unique lifting system holds drums securely with a locking safety handle. Steel construction with a baked-in powder-coated toughness.

Model DL-31 may be used to lift 30 and 55 gallon steel drums with either an overhead chain or fork truck. Fork/hook opening measures 5½"W x 2¼"H. Steel construction with a baked-in powder-coated toughness.

Designed exclusively for lifting closed and open-head drums with a scured lid installed.

| MODEL NUMBER | ACCEPTABLE DRUM SIZES | OPERATION METHOD | UNIFORM CAPACITY | WEIGHT (POUND) |
|--------------|-----------------------|------------------|------------------|----------------|
| FDT-22 | 30 & 55 GALLON | CHAIN/HOIST | 1,000 lb. | 23 |
| DL-31 | 30 & 55 GALLON | FORK/CHAIN | 1,500 lb. | 29 |



model TDR-55

Tilting Drum Rings

Easily transport steel drums with your fork truck and the Tilting Drum Rings. Pivoting fork pockets allow you to manually rotate drum to dispense light materials. To use, slip the band over the belly of the steel drum and tighten the lock to secure the band around the belly of the drum. Usable fork openings are 5¾"W x 3"H each. Welded steel construction.

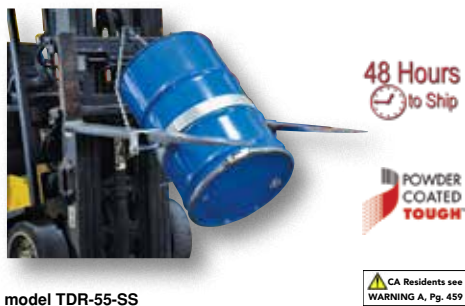

model TDR-55-SS

| MODEL NUMBER | ACCEPTABLE DRUM SIZE | MATERIAL & FINISH | UNIFORM* CAPACITY | WEIGHT (POUND) |
|--------------|----------------------|---------------------------|-------------------|----------------|
| TDR-30 | 30 GALLON | POWDER COAT STEEL | 1,200 lb. | 22 |
| TDR-55 | 55 GALLON | POWDER COAT STEEL | 1,200 lb. | 24 |
| TDR-30-G | 30 GALLON | GALVANIZED CARBON STEEL | 1,200 lb. | 23 |
| TDR-55-G | 55 GALLON | GALVANIZED CARBON STEEL | 1,200 lb. | 24 |
| TDR-30-SS | 30 GALLON | GRADE 304 STAINLESS STEEL | 1,200 lb. | 24 |
| TDR-55-SS | 55 GALLON | GRADE 304 STAINLESS STEEL | 1,200 lb. | 25 |

*CAPACITY IS BASED ON FULL DRUMS
HALF-FULL DRUMS ARE RATED AT 600 LB. UNIFORM CAPACITY



model NVD-40

Near Vertical Drum Lifter

This product is designed for the transportation of 55 gallon closed head steel drums with an overhead lifting device. Adjustable attachment point allows drum to be lifted from a horizontal to a near-vertical position. Easily attaches to any drum with both a top and bottom lip. Adjustable top attachment point for use with different height drums. Steel construction. Blue baked-in powder-coated toughness. Hook Plate sold separately, see page 190.

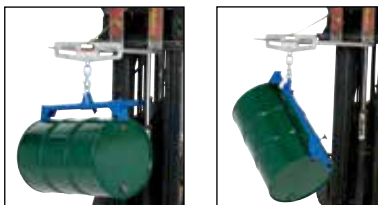

| MODEL NUMBER | ACCEPTABLE DRUM HEIGHTS | UNIFORM CAPACITY | WEIGHT (POUND) |
|--------------|-------------------------|------------------|----------------|
| NVD-40 | 16" TO 40" | 1,000 lb. | 23 |

Horizontal Semi-Automatic Drum Tong

Made to lift drums with an overhead hoist. Suitable for 55 gallon open top or tight head steel and fiber drums that have a ring. To operate, set locking lever in locked open position. When centered over the horizontal drum, release lever to allow hooks to fall and locate under both rims. Hook automatically engages as it is lifted and disengages as drum is set down. Designed exclusively for lifting closed and open-head steel drums with a secured lid installed.

| MODEL NUMBER | ACCEPTABLE DRUM TYPES | UNIFORM CAPACITY | WEIGHT (POUND) |
|-----------------------|-----------------------|------------------|----------------|
| DTH-1000 [®] | STEEL & FIBER DRUMS | 1,000 lb. | 18 |



Drum Slings

Lift drums in the horizontal position quickly and easily with these Drum Slings. Handle open or closed head steel drums. The large steel lifting ring accommodates most overhead lifting systems. Choose from brass or galvanized iron construction. Accepts 30 and 55 gallon steel drums.

| MODEL NUMBER | ACCEPTABLE DRUM SIZES | STYLE | UNIFORM CAPACITY | WEIGHT (POUND) |
|-------------------------|-----------------------|------------|------------------|----------------|
| DCS-750-B [®] | 30 & 55 GALLON | BRASS | 750 lb. | 6 |
| DCS-1000-B | 30 & 55 GALLON | BRASS | 1,000 lb. | 6 |
| DCS-2000-G [®] | 30 & 55 GALLON | GALVANIZED | 2,000 lb. | 7 |

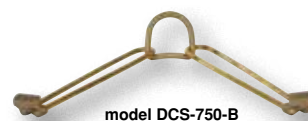

Manual Drum Uprinder

Manual Drum Uprinder provides the leverage needed for tilting horizontal drums to the vertical position. Constructed of solid steel for long life. Wide toe plate prevents denting on barrel sides. Narrow top plate grabs a variety of chimes on steel, plastic, and fiber drums. Model has a 600 pound capacity and can be used with full or empty drums. Baked-in powder-coated toughness. Designed exclusively for lifting closed and open-head steel drums with a secured lid installed.

| MODEL NUMBER | DESCRIPTION | HANDLE LENGTH | WEIGHT (POUND) |
|---------------------|------------------------------|---------------|----------------|
| DTP-11 [®] | UPENDER FOR HORIZONTAL DRUMS | 41" | 7 |

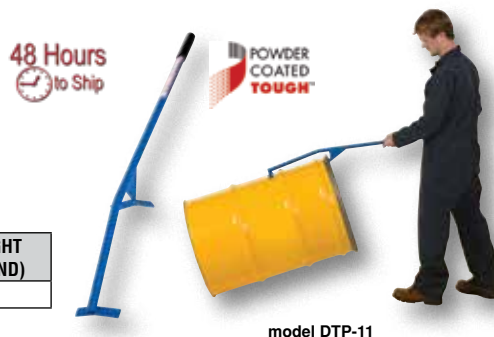

Drum Stick

Provides an ergonomic solution to pushing/pulling a drum while on a dolly. Make drum transporting on a dolly easier and cleaner. Easily and quickly attaches to drum ring. Features rubber hand grips and a safety yellow baked-in powder-coated toughness. Works on open and closed head drums. This multipurpose tool can open and close almost any size bung plug.

| MODEL NUMBER | ACCEPTABLE DRUM SIZES | OVERALL WIDTH | OVERALL HEIGHT | WEIGHT (POUND) |
|------------------------|-----------------------|---------------|---------------------------------|----------------|
| DRUM-STIK [®] | 30 & 55 GALLON | 18¾" | 4 ⁵ / ₈ " | 5 |



Drum Tiers for safe drum stacking

Increase storage space by stacking your steel drums with our Drum Tiers. The economical Drum Tiers are designed to help maximize floor space in a safe and convenient manner. The lightweight design utilizes one person operation. Handles steel drums up to five (5) units high. Tabs keep drums aligned when stacked.

| MODEL NUMBER | ACCEPTABLE DRUM SIZE | OVERALL DIAMETER | UNIFORM CAPACITY | WEIGHT (POUND) |
|---------------------|----------------------|------------------|------------------|----------------|
| DTR-20 | 30 GALLON | 20½" | 2,300 lb. | 14 |
| DTR-24 [®] | 55 GALLON | 24½" | 2,300 lb. | 16 |
| DTR-28 | 85 GALLON | 28" | 2,300 lb. | 26 |





model DRUM-ST

USE WITH PALLET TRUCKS

48 Hours to Ship

USE WITH FORK TRUCKS



Drum Stand

Drum Stand provides economical and convenient portability. These stands offer a uniquely designed understructure that allows for transporting of drums with either a pallet truck or fork truck. Accepts steel, plastic, and fiber drums.

The Drum Stand also allows for single drum stacking for easy storage of drums up to three (3) high (empty stands are nestable and stackable). All welded steel construction. Stands include a safety yellow baked-in powder-coated toughness.

| MODEL NUMBER | ACCEPTABLE DRUM SIZE | OVERALL SIZE (W x H) | UNIFORM CAPACITY | WEIGHT (POUND) |
|----------------------|----------------------|---------------------------------------|------------------|----------------|
| DRUM-ST [Ⓢ] | 55 GALLON | 24 ⁷ / ₈ " x 6" | 1,500 lb. | 40 |



OVERPACK DRUM DOLLY series DRUM-SP

48 Hours to Ship

Overpack Drum Dollies

Transport containment units with Overpack Drum Dollies, series DRUM-SP. Designed to hold drum spill containers. Dollies roll smoothly on four (4) swivel casters. Steel construction. Does NOT work with the SCC-series Overpack Containers.

| MODEL NUMBER | OUTSIDE DIAMETER | INSIDE DIAMETER | CASTER TYPE | UNIFORM CAPACITY | WEIGHT (POUND) |
|------------------------------|----------------------------------|----------------------------------|-------------|------------------|----------------|
| DRUM-SP-28-12-C [Ⓢ] | 28 ³ / ₈ " | 28" | STEEL | 1,200 lb. | 34 |
| DRUM-SP-28-9-H [Ⓢ] | 28 ³ / ₈ " | 28" | HARD RUBBER | 900 lb. | 32 |
| DRUM-SP-32-12-C [Ⓢ] | 32" | 31 ⁵ / ₈ " | STEEL | 1,200 lb. | 37 |
| DRUM-SP-32-9-H [Ⓢ] | 32" | 31 ⁵ / ₈ " | HARD RUBBER | 900 lb. | 34 |



A



48 Hours to Ship

Mobile Drum Dollies

Transport ordinary or specialty drums easily with these multipurpose Drum Dollies. Various constructions, designs, caster types, and sizes to accommodate your application. Assembly required.

A) The Octo Drum Dolly, model OCTO-55-CI, will transport 55 gallon drums weighing up to 2,000 pounds. Rolls on eight (8) 4" x 1¹/₄" cast iron swivel casters for maximum stability.

B) Heavy-Duty Drum Dolly, model DRUM-HD, can transport 55 gallon drums. With a capacity of 2,000 pounds, this dolly will transport your heavier drums from location to location. Four (4) 4" x 2" locking swivel glass-filled nylon casters with brakes standard.

C) Adjustable Drum Dollies, series DRUM-X, accommodates 30, 55, 85, and 95 gallon drums or adjusts to fit multiple square and rectangular crates. Blue baked-in powder-coated toughness.



B

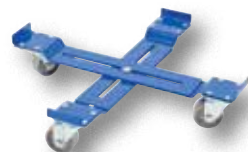

C



D



E



E



F

| TYPE | MODEL NUMBER | DESCRIPTION | ACCEPTABLE DRUM SIZE (GALLON) | CASTER TYPE | HEIGHT | UNIFORM CAPACITY | WEIGHT (POUND) |
|------|---------------------------|-----------------|-------------------------------|--------------------|----------------------------------|------------------|----------------|
| A | OCTO-55-CI [Ⓢ] | OCTO DOLLY | 55 | CAST IRON | | 2,000 lb. | 40 |
| B | DRUM-HD [Ⓢ] | HEAVY-DUTY | 55 | GLASS-FILLED NYLON | | 2,000 lb. | 40 |
| C | DRUM-X-H [Ⓢ] | ADJUSTABLE | 30, 55, 85 & 95 | HARD RUBBER | 5 ⁵ / ₁₆ " | 1,000 lb. | 19 |
| C | DRUM-X-C [Ⓢ] | ADJUSTABLE | 30, 55, 85 & 95 | CAST STEEL | 5 ¹ / ₁₆ " | 1,200 lb. | 22 |
| D | DDO-P103-HT3 [Ⓢ] | CAST IRON | 55 & 30 | HARD RUBBER | 6 ³ / ₁₆ " | 550 lb. | 37 |
| E | DRUM-SS-55-H [Ⓢ] | STAINLESS STEEL | 55 | HARD RUBBER | 6" | 800 lb. | 23 |
| E | DRUM-FSD-SS-5-N | STAINLESS STEEL | 55 | NYLON | 7" | 1,100 lb. | 20 |
| F | DRUM-DRH-HR [Ⓢ] | WITH HANDLE | 5, 30 & 55 | HARD RUBBER | 6 ¹ / ₄ " | 1,000 lb. | 23 |

Multi-Purpose Dollies

Multi-Purpose Dollies have a high polished bright zinc finish for corrosion resistance and four (4) 3" x 1¼" swivel casters. Each unit comes with a 4 foot long nylon pull strap that helps in transporting down aisles or over thresholds. Rubber-coated hook allows strap to hook on top of drum for storage.

Quad Dolly, series *DRUM-QUAD*, can transport a 5 gallon pail, 30 or 55 gallon drum, or LP gas tank. Available with hard rubber or cast iron wheels. Also available in Stainless Steel.

Tri Dolly, series *DRUM-TRI*, will transport 5 gallon pails, 30 gallon drums, or LP gas tank.

| MODEL NUMBER | CASTER TYPE | UNIFORM CAPACITY | WEIGHT (POUND) |
|---------------------------|-------------|------------------|----------------|
| DRUM-QUAD-H Ⓢ | HARD RUBBER | 900 lb. | 22 |
| DRUM-QUAD-C Ⓢ | CAST IRON | 1,200 lb. | 24 |
| DRUM-QUAD-CS-SS *Ⓢ | HARD RUBBER | 900 lb. | 24 |
| DRUM-TRI-H Ⓢ | HARD RUBBER | 900 lb. | 19 |
| DRUM-TRI-C Ⓢ | CAST IRON | 1,200 lb. | 22 |

*STAINLESS STEEL



series DRUM-QUAD

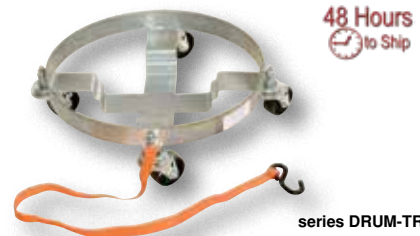

series DRUM-TRI

Tilting Drum Dollies

Tilt drums 10° for better liquid extraction. Tilting feature is foot-operated and locks into place when activated. This feature only works with the outside/ biggest drum that the unit will accommodate. Patent pending.

DRUM-QUAD, can transport a 5 gallon pail, 30 or 55 gallon drum, or LP gas tank.

DRUM-TRI, will transport 5 gallon pails, 30 gallon drums, or LP gas tank.

DRUM-DRH-HR-TLT, will transport 5 gallon pails and 30 or 55 gallon drums.

| MODEL NUMBER | CASTER TYPE | TILT CAPACITY | UNIFORM CAPACITY | WEIGHT (POUND) |
|--------------------------|-------------|---------------|------------------|----------------|
| DRUM-QUAD-H-TLT Ⓢ | HARD RUBBER | 200 lb. | 900 lb. | 28 |
| DRUM-QUAD-C-TLT Ⓢ | CAST IRON | 200 lb. | 1,200 lb. | 28 |
| DRUM-TRI-H-TLT Ⓢ | HARD RUBBER | 200 lb. | 900 lb. | 22 |
| DRUM-TRI-C-TLT Ⓢ | CAST IRON | 200 lb. | 1,200 lb. | 24 |
| DRUM-DRH-HR-TLT Ⓢ | HARD RUBBER | 200 lb. | 1,000 lb. | 27 |



DRUM-QUAD & DRUM-TRI include a 4 ft. long nylon pull strap

48 Hours
to Ship



model DRUM-DRH-HR-TLT includes a 36" metal handle.

Polyethylene Drum Dollies

Manufactured from high impact strength polyethylene, these drum dollies are lightweight, yet strong. Dollies come standard with four (4) 3" swivel hard rubber casters and they are suited for both indoor and outdoor applications.

| MODEL NUMBER | ACCEPTABLE DRUM SIZE | POLY DIAMETER | UNIFORM CAPACITY | COLOR | WEIGHT (POUND) |
|---------------------------|----------------------|---------------|------------------|-------|----------------|
| DRUM-DP-HD-30-BK Ⓢ | 5* & 30 GALLON | 20" | 600 lb. | BLACK | 15 |
| DRUM-DP-HD-30-BU Ⓢ | 5* & 30 GALLON | 20" | 600 lb. | BLUE | 15 |
| DRUM-DP-HD-55-BK Ⓢ | 30 & 55 GALLON | 24¾" | 600 lb. | BLACK | 17 |
| DRUM-DP-HD-55-BU Ⓢ | 30 & 55 GALLON | 24¾" | 600 lb. | BLUE | 17 |
| DRUM-DP-LD-30-BK Ⓢ | 5* & 30 GALLON | 20" | 300 lb. | BLACK | 14 |
| DRUM-DP-LD-30-BU Ⓢ | 5* & 30 GALLON | 20" | 300 lb. | BLUE | 14 |
| DRUM-DP-LD-55-BK Ⓢ | 30 & 55 GALLON | 24¾" | 300 lb. | BLACK | 16 |
| DRUM-DP-LD-55-BU Ⓢ | 30 & 55 GALLON | 24¾" | 300 lb. | BLUE | 16 |

*5 GALLON BUCKETS



series DRUM-DP-55

48 Hours
to Ship

New



Multi-Level Plastic Drum Dolly

Heavy-duty molded plastic (HDPE) construction with support rib understructure. Two tier design for use with both 55 and 30 gallon drums. Usable opening is 23¾" for 55 gallon drums and 18¾" for 30 gallon drums. Rolls smoothly on five (5) swivel 3" x 1¼" hard rubber casters.

| MODEL NUMBER | ACCEPTABLE DRUM SIZES | OVERALL SIZE (D x H) | UNIFORM CAPACITY | WEIGHT (POUND) |
|-------------------|-----------------------|----------------------|------------------|----------------|
| DRUM-PDD Ⓢ | 30 & 55 GALLON | 24¼" x 7" | 600 lb. | 16 |



model DRUM-PDD

48 Hours
to Ship



Round All-Fiber Drums

Lightweight, cost effective design for an alternative to steel drums. For use with dry or solid materials. All-fiber construction. Does not include any steel components. Features flat tops and bottoms for better stacking to save storage space. FDR-30 and FDR-55 include a bag inside of drum.

| MODEL NUMBER | VOLUME CAPACITY | UNIFORM CAPACITY | DIAMETER | HEIGHT | UN SPECIFICATIONS | WEIGHT (POUND) |
|--------------|-----------------|------------------|----------------------------------|------------------------------------|-------------------|----------------|
| FDR-5 | 5 GAL | 130 lb. | 11 ⁵ / ₈ " | 12 ³ / ₈ " | UN 1G/X60/S | 4 |
| FDR-12 | 12 GAL | 130 lb. | 12 ⁷ / ₈ " | 22 ¹³ / ₁₆ " | UN 1G/X60/S | 7 |
| FDR-30 | 30 GAL | 260 lb. | 18 ⁷ / ₈ " | 26" | UN 1G/Y92/S | 15 |
| FDR-55 | 55 GAL | 260 lb. | 21 ⁷ / ₈ " | 35 ¹ / ₈ " | UN 1G/Y100/S | 21 |

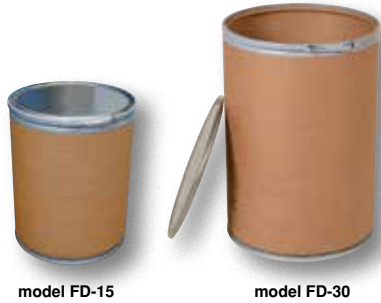

model FD-15

model FD-30

Fiber Drums

A lightweight and cost effective alternative to steel drums. Open Head Fiber Drums are a great choice for storage and shipping of dry or solid materials. Steel chime reinforces the top and bottom to keep drum shape and secure contents. Lock rim side lever lock with steel lid cover.

| MODEL NUMBER | VOLUME CAPACITY | UNIFORM CAPACITY | DIAMETER | HEIGHT | UN SPECIFICATIONS | WEIGHT (POUND) |
|--------------|-----------------|------------------|----------|----------------------------------|-------------------|----------------|
| FD-15 | 15 GAL | 150 lb. | 16" | 20" | UN 1G/Y120/S | 8 |
| FD-30 | 30 GAL | 225 lb. | 19" | 27 ¹ / ₄ " | UN 1G/Y172/S | 14 |
| FD-55 | 55 GAL | 550 lb. | 22" | 36" | UN 1G/Y200/S | 18 |



CLOSED HEAD STEEL DRUM

OPEN HEAD STEEL DRUM

Steel Drums Standard and U.N. Rated

Steel Drums

Quality cold rolled drums meet most U.N. requirements for shipping and packaging. Drum interior is coated with a corrosion inhibitor. Open head drums have removable lids and 12 gauge bolt ring closure. Drums have a 2" and 3/4" bung. Additional sizes and stainless steel drums available, contact factory. Steel surcharges may apply, contact factory.

Stainless Steel Drums

High quality 304 stainless drums are finished in a 2B polish. Meets most U.N. requirements for shipping and packaging. Excellent corrosion resistance makes these stainless steel drums superior for storage and shipping of foods and chemicals. Open head drums have removable lids and 12 gauge bolt ring closure. 2" and 3/4" bung standard.

Quick Release Lever Option

This option is used with open head drums only. Lever automatically tightens drum lids to U.N. specifications. Replaces standard 12 gauge bolt ring closure.



QUICK RELEASE LEVER OPTION

STANDARD STEEL DRUMS

| MODEL NUMBER | VOLUME CAPACITY | GAUGE TOP/BODY/BOTTOM | STYLE | UN SOLID | UN LIQUID | WEIGHT (POUND) |
|---------------|-----------------|-----------------------|-------------|----------------|------------------|----------------|
| SD-30-OH-02 | 30 GALLON | 20 / 20 / 20 | OPEN HEAD | 1A2 / X200 / S | 1A2 / Y1.5 / 150 | 26 |
| SD-30-OH-05 | 30 GALLON | 18 / 18 / 18 | OPEN HEAD | 1A2 / X235 / S | 1A2 / Y1.5 / 150 | 33 |
| SD-30-OH-07 | 30 GALLON | 16 / 18 / 18 | OPEN HEAD | 1A2 / X235 / S | 1A2 / Y1.5 / 150 | 35 |
| SD-30-OH-07-Q | 30 GALLON | 16 / 18 / 18 | OPEN HEAD | 1A2 / X235 / S | 1A2 / Y1.5 / 150 | 35 |
| SD-55-OH-04 | 55 GALLON | 18 / 20 / 20 | OPEN HEAD | 1A2 / Y425 / S | 1A2 / Y1.2 / 100 | 38 |
| SD-55-OH-06 | 55 GALLON | 18 / 18 / 18 | OPEN HEAD | 1A2 / X435 / S | 1A2 / Y1.5 / 150 | 48 |
| SD-55-OH-07 | 55 GALLON | 16 / 18 / 18 | OPEN HEAD | 1A2 / X400 / S | 1A2 / Y1.5 / 150 | 50 |
| SD-55-OH-07-Q | 55 GALLON | 16 / 18 / 18 | OPEN HEAD | 1A2 / X400 / S | 1A2 / Y1.4 / 150 | 50 |
| SD-55-OH-08 | 55 GALLON | 16 / 16 / 16 | OPEN HEAD | 1A2 / X430 / S | 1A2 / Y1.5 / 175 | 60 |
| SD-55-OH-08-Q | 55 GALLON | 16 / 16 / 16 | OPEN HEAD | 1A2 / X430 / S | 1A2 / Y1.4 / 175 | 60 |
| SD-30-TH-08 | 30 GALLON | 20 / 20 / 20 | CLOSED HEAD | N/A | 1A1 / Y1.5 / 300 | 26 |
| SD-30-TH-13 | 30 GALLON | 16 / 20 / 16 | CLOSED HEAD | N/A | 1A1 / Y1.8 / 300 | 31 |
| SD-55-TH-13 | 55 GALLON | 20 / 20 / 20 | CLOSED HEAD | N/A | 1A1 / Y1.2 / 200 | 37 |
| SD-55-TH-15 | 55 GALLON | 18 / 18 / 18 | CLOSED HEAD | N/A | 1A1 / Y1.8 / 300 | 48 |
| SD-55-TH-16 | 55 GALLON | 16 / 16 / 16 | CLOSED HEAD | N/A | 1A1 / Y1.8 / 300 | 60 |

SUFFIX "Q" INDICATES THE QUICK RELEASE LEVER OPTION

STAINLESS STEEL DRUMS

| MODEL NUMBER | VOLUME CAPACITY | GAUGE TOP/BODY/BOTTOM | STYLE | UN SOLID | UN LIQUID | WEIGHT (POUND) |
|--------------|-----------------|-----------------------|-------------|----------------|------------------|----------------|
| SSD-30-TH-03 | 30 GALLON | 18 / 18 / 18 | CLOSED HEAD | N/A | 1A1 / X1.2 / 300 | 33 |
| SSD-30-OH-04 | 30 GALLON | 18 / 18 / 18 | OPEN HEAD | 1A2 / X225 / S | 1A2 / Y1.5 / 150 | 35 |
| SSD-55-OH-01 | 55 GALLON | 16 / 16 / 16 | OPEN HEAD | 1A2 / X430 / S | 1A2 / Y1.5 / 200 | 60 |
| SSD-55-TH-03 | 55 GALLON | 16 / 16 / 16 | CLOSED HEAD | N/A | 1A1 / X1.8 / 300 | 48 |
| SSD-55-TH-04 | 55 GALLON | 16 / 16 / 16 | CLOSED HEAD | N/A | 1A1 / X1.8 / 550 | 60 |

Drum Heaters

Quickly and efficiently heat-up your steel drums or pails. Easily adjust thermostat set-point: 50 to 425°F. for steel drums and 50 to 160°F. on poly drums. This extra-wide 4" silicone rubber band heater is moisture and chemical resistant. Multi-stranded grounded heating element provides uniform heat and a long service life. Spring closure can be expanded 3". Unit comes with a 6-foot-long power cord, grounded 3-prong. The -CA suffix indicates models that are CSA approved for use in Canada only. Feature a 6 foot long power cord with no plug.

| MODEL NUMBER | ACCOMMODATES DRUM SIZE | VOLTS | WATTS | STRAP SIZE | AMPS | WEIGHT (POUND) |
|---------------------------|------------------------|-------|-------|------------|------|----------------|
| STEEL DRUM HEATERS | | | | | | |
| DRH-S-5 [Ⓢ] | 5 | 120 | 550 | 4" | 4.5 | 3 |
| DRH-S-15 [Ⓢ] | 15 | 120 | 700 | 4" | 4.5 | 3 |
| DRH-S-30 [Ⓢ] | 30 | 120 | 1000 | 4" | 4.5 | 4 |
| DRH-S-55 [Ⓢ] | 55 | 120 | 1200 | 4" | 4.5 | 5 |
| DRH-S-55-240 | 55 | 240 | 1200 | 4" | 2.3 | 5 |
| DRH-S-5-CA | 5 | 120 | 550 | 4" | 4.5 | 3 |
| DRH-S-15-CA | 15 | 120 | 700 | 4" | 4.5 | 3 |
| DRH-S-30-CA | 30 | 120 | 1000 | 4" | 4.5 | 4 |
| DRH-S-55-CA | 55 | 120 | 1200 | 4" | 4.5 | 5 |
| DRH-S-55-240-CA | 55 | 240 | 1200 | 4" | 2.3 | 5 |
| POLY DRUM HEATERS | | | | | | |
| DRH-P-5 [Ⓢ] | 5 | 120 | 150 | 4" | 4.5 | 3 |
| DRH-P-55 [Ⓢ] | 55 | 120 | 300 | 4" | 4.5 | 5 |
| DRH-P-5-CA | 5 | 120 | 300 | 4" | 4.5 | 3 |
| DRH-P-55-CA | 55 | 120 | 150 | 4" | 4.5 | 5 |

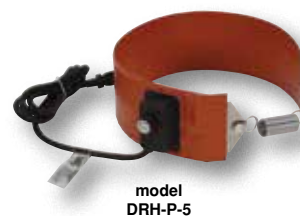

Drum Liners

Flexible Drum Liners revolve around the concept of "no loss of product" and "total recovery of product." The cylindrical 360° shape of the round bottom liner seal prevents product from "lodging" in the wrinkles and creases that are typical in "flat" bottom liners. Product weight is distributed around the entire seal so that seal stress is reduced. Low Density Polyethylene construction unless otherwise noted.

Rigid Drum Liners are constructed from seamless polyethylene unless otherwise noted. Rigid liners make disposing of materials easy, plus they help keep our environment cleaner by ensuring the maximum recovery of product. Saves you money by extending the lifetime of drums and reducing the cost to clean and recondition them. All rigid drum liners are made using prime virgin FDA compliant polyolefin resins.

| FLEXIBLE, ROUND BOTTOM DRUM LINERS | | | | | | |
|---|--------------------|----------|-----------------------|-----------|-----------|----------------|
| MODEL NUMBER | TYPE | DIAMETER | LAY FLAT SIZE (W x H) | THICKNESS | CASE QTY. | WEIGHT (POUND) |
| 55 GALLON DRUMS | | | | | | |
| DLINE-55-4-P | PEEL OVER | 22½" | 38" x 40" | 4 MIL | 100 | 55 |
| DLINE-55-8-P | PEEL OVER | 22½" | 38" x 40" | 8 MIL | 50 | 64 |
| DLINE-55-10-P | PEEL OVER | 22½" | 38" x 40" | 10 MIL | 50 | 66 |
| DLINE-55-4-T | TIE OFF | 22½" | 38" x 53" | 4 MIL | 100 | 70 |
| DLINE-55-8-T | TIE OFF | 22½" | 38" x 53" | 8 MIL | 50 | 72 |
| DLINE-55-10-T | TIE OFF | 22½" | 38" x 53" | 10 MIL | 50 | 88 |
| DLINE-55-8-T-AS | TIE OFF ANTISTAT | 22½" | 38" x 53" | 8 MIL | 50 | 72 |
| DLINE-55-4-PP* | PEEL OVER | 22½" | 38" x 40" | 4 MIL | 100 | 59 |
| DLINE-55-4-T-PP* | TIE OFF | 22½" | 38" x 53" | 4 MIL | 100 | 76 |
| 15 GALLON DRUMS | | | | | | |
| DLINE-15-P | PEEL OVER | 16" | 26" x 36" | 4 MIL | 200 | 71 |
| DLINE-15-T | TIE OFF | 16" | 26" x 48" | 4 MIL | 150 | 71 |
| 30 GALLON DRUMS | | | | | | |
| DLINE-30-P | PEEL OVER | 19" | 30" x 36" | 4 MIL | 150 | 60 |
| DLINE-30-T | TIE OFF | 19" | 30" x 48" | 4 MIL | 150 | 71 |
| RIGID DRUM LINERS | | | | | | |
| MODEL NUMBER | TYPE | DIAMETER | HEIGHT | THICKNESS | CASE QTY. | WEIGHT (POUND) |
| 55 GALLON DRUMS | | | | | | |
| DLINE-55-15 | SMOOTH | 22½" | 34" | 15 MIL | 20 | 35 |
| DLINE-55-15-ACC | ACCORDION | 22½" | 34" | 15 MIL | 20 | 37 |
| DLINE-55-15-ACC-AS | ACCORDION ANTISTAT | 22½" | 34" | 15 MIL | 20 | 37 |
| DLINE-55-18 | SMOOTH | 22½" | 34" | 18 MIL | 15 | 37 |
| DLINE-55-18-ACC | ACCORDION | 22½" | 34" | 18 MIL | 15 | 33 |
| DLINE-55-18-AS | SMOOTH ANTI-STAT | 22½" | 34" | 18 MIL | 15 | 37 |
| DLINE-55-15-PP* | SMOOTH | 22½" | 34" | 15 MIL | 12 | 33 |
| DLINE-30-15-ACC | 30 GAL ACCORDION | 19" | 28½" | 15 MIL | 25 | 30 |

*POLYPROPYLENE CONSTRUCTION



model
DLINE-55-15

48 Hours
to Ship



model DD-9



model DD-9-NS

CA Residents see
WARNING A, Pg. 459



model DD-10



model D-HEAD-1



model DD-M



model DD-EZ-M



model DD-EZ-E



model DD-EX-E



model DD-EX-A

CA Residents see
WARNING A, Pg. 459

Manual Drum Deheaders

Convert your closed head steel drums into storage containers with our Drum Deheaders.

The *DD-9* and *DD-9-NS* can be adjusted to open steel drums with different thicknesses. The blade is angled for maximum penetration and flattens the cut edge so there are no sharp or jagged edges. Replacement blades available.

Model *DD-9-NS* features a bronze, spark resistant alloy.

Model *DD-10* features an ergonomic handle allowing smoother operation to cut drum.

Quickly remove the head of a steel drum with our Express-Open Drum Deheader! Unique design, model *D-HEAD-1*, is similar to a household can-opener and is very easy to use. Includes vice-grip style mechanism for securely attaching unit to drum. Inside cutting blade does not leave a sharp edge on the drum. ONLY use either a 1/2" manual ratchet wrench or electric drill to operate the deheader ratchet (ratchet drive not included).

WARNING: Improper use of this drum deheader might result in personal injury or damage to the deheader. DO NOT use a pneumatic or electric impact wrench to operate the deheader ratchet. Replacement blades available separately, model *D-HEAD-B*. Both styles open 30 and 55 gallon steel drums and 5 gallon pails.

| MODEL NUMBER | DESCRIPTION | WEIGHT (POUND) |
|--------------------|--|----------------|
| DD-9 ☺ | STANDARD DRUM DEHEADER | 7 |
| DDB-1 ☺ | REPLACEMENT BLADE FOR DD-9 | 2 |
| DD-9-NS ☺ | MANUAL DRUM DEHEADER, SPARK RESISTANT | 7 |
| DDB-1-NS ☺ | REPLACEMENT CUTTING BLADE, SPARK RESISTANT | 2 |
| DD-10 ☺ | MANUAL DRUM DEHEADER | 8 |
| DDB-2 ☺ | REPLACEMENT BLADE FOR DD-10 | 3 |
| D-HEAD-1 ☺ | EXPRESS-OPEN DRUM DEHEADER | 4 |
| D-HEAD-B ☺ | REPLACEMENT BLADE FOR D-HEAD-1 | 1 |
| D-HEAD-GK ☺ | REPLACEMENT GEAR/BUSHING KIT FOR D-HEAD-1 | 1 |

Drum Deheaders

Manual Drum Deheader, *model DD-M* is for use with occasional drum deheading. Provides ribbed grip for comfort. Inside chime cut.

Burr-Free Manual Drum Deheader, *model DD-EZ-M* is a ratchet style manual drum deheader. For use with moderate drum volumes and leaves a burr-free edge. Inside chime cut.

Electric Drum Deheader, *model DD-EZ-E* is a compact, portable, self-propelled, electric unit. It is also quiet, easy to use, and designed for moderate drum deheading and leaves a burr-free edge. 1/3 HP, 110V, 60 Hz (220V available, contact factory). Inside chime cut.

High Duty Drum Deheader, *model DD-EX-E (electric) and model DD-EX-A (air powered)* are designed for moderate to high drum deheading. Deheads a drum in less than 1 minute, leaves a burr-free edge, and is long lasting. 1/3 HP, 110V, 60 Hz (220V available, contact factory). 60-100 psi, 25 cfm. FLR is required; not included. Inside chime cut.

| MODEL NUMBER | DESCRIPTION | WEIGHT (POUND) |
|----------------|---|----------------|
| DD-M | MANUAL DRUM DEHEADER (1 pass) | 7 |
| DD-EZ-M | BURR-FREE MANUAL DRUM DEHEADER (3-5 pass) | 34 |
| DD-EZ-E | ELECTRIC DRUM DEHEADER (3-5 pass) | 34 |
| DD-EX-E | HIGH DUTY ELECTRIC DRUM DEHEADER (1-2 pass) | 80 |
| DD-EX-A | AIR POWERED DRUM DEHEADER (1-2 pass) | 80 |
| NFCW** | BRONZE NON-FERROUS CUTTING WHEEL | 1 |

**FOR USE WITH DD-EX-A

Galvanized Steel Drum Covers

Galvanized Steel Drum Covers for 55 gallon drums. Manufactured from 26 gauge galvanized steel. Cover drum tops for added protection. Perimeter rim is beaded for safety.

Recycling Top, *model CAN-CAP-G*, includes a "CANS ONLY" decal. Disposal hole measures 3 $\frac{1}{8}$ ".

| MODEL NUMBER | ACCEPTABLE DRUM TYPES | INSIDE DIAMETER | WEIGHT (POUND) |
|------------------------|-------------------------|--------------------|----------------|
| DC-235 [Ⓢ] | CLOSED HEAD | 24 $\frac{1}{4}$ " | 6 |
| DC-245 [Ⓢ] | OPEN HEAD | 25" | 6 |
| DC-245-H [Ⓢ] | OPEN HEAD (WITH HANDLE) | 25" | 6 |
| CAN-CAP-G [Ⓢ] | OPEN HEAD | 24 $\frac{1}{2}$ " | 4 |



model DC-235



model DC-245-H



model CAN-CAP-G

48 Hours
to Ship

CA Residents see
WARNING A, Pg. 459

Drum Covers

Protect your drums from bung seepage and unprotected outdoor storage situations. Convenient, and designed for years of reliable use. *Models DC-TP* and *DC-TPO* are constructed of flexible 60 mil thick polyethylene. Features an ultraviolet screen. Temperature range is -50 to +212°F.

Models DC-P have a low-density polyethylene construction with detents to hold the lid securely. Other colors are available - call factory.

*: Units work with closed head and open head drums with lid and ring closure removed.

** : Units work with closed head and open head drums.

| MODEL NUMBER | COLOR | DIAMETER | QTY. PER PACKAGE | WEIGHT (POUND) |
|------------------------|--------------------------------|--------------------|------------------|----------------|
| 55 GALLON DRUMS | | | | |
| DC-TP [Ⓢ] | CLEAR, CLOSED HEAD STEEL DRUMS | 25" | 5 | 7 |
| DC-TPO [Ⓢ] | CLEAR, OPEN HEAD STEEL DRUMS | 25" | 5 | 6 |
| DC-TP-B [Ⓢ] | BLACK, CLOSED HEAD STEEL DRUMS | 25" | 5 | 8 |
| DC-TPO-B [Ⓢ] | BLACK, OPEN HEAD STEEL DRUMS | 25" | 5 | 7 |
| DC-P-55-BK* | BLACK, CLOSED HEAD | 25" | 1 | 10 |
| DC-P-55-BU* | BLUE, CLOSED HEAD | 25" | 1 | 10 |
| DC-P-55-UF-BK** | BLACK, OPEN & CLOSED HEAD | 24 $\frac{5}{8}$ " | 1 | 3 |
| DC-P-55-UF-BU** | BLUE, OPEN & CLOSED HEAD | 24 $\frac{5}{8}$ " | 1 | 3 |
| 30 GALLON DRUMS | | | | |
| DC-P-30-BK* | BLACK, CLOSED HEAD | 20" | 1 | 7 |
| DC-P-30-BU* | BLUE, CLOSED HEAD | 20" | 1 | 7 |



model DC-TP

New

48 Hours
to Ship



model DC-TPO-B



series DC-P-55-

series DC-P-55-UF-

Recycling Lids

Collecting aluminum cans or plastic bottles could not be easier with Recycling Lids. Fits on open head plastic or steel drums only with lid and ring are removed. Low-density polyethylene construction. Fits snug to resist blowing off in outdoor environments or being tampered with by people or animals. *CANF* models have a flap to help discourage the removal of contents.

*: Units work with open head drums with the lid and ring closure removed.

** : Units work with open head drums with the lid removed.

| MODEL NUMBER | COLOR | DIAMETER | CENTER OPENING | WEIGHT (POUND) |
|------------------------|-------|--------------------|----------------|----------------|
| 55 GALLON DRUMS | | | | |
| CAN-CAP-P | BLUE | 24 $\frac{1}{2}$ " | 7" | 4 |
| DC-P-55-CAN-BK* | BLACK | 24 $\frac{3}{4}$ " | 4" | 10 |
| DC-P-55-CAN-BU* | BLUE | 24 $\frac{3}{4}$ " | 4" | 10 |
| DC-P-55-CANF-BK* | BLACK | 24 $\frac{3}{4}$ " | 4" | 10 |
| DC-P-55-CANF-BU* | BLUE | 24 $\frac{3}{4}$ " | 4" | 10 |
| DC-P-55-CAN-UF-BK** | BLACK | 24 $\frac{1}{2}$ " | 4" | 10 |
| DC-P-55-CAN-UF-BU** | BLUE | 24 $\frac{1}{2}$ " | 4" | 10 |
| DC-P-55-CANF-UF-BK** | BLACK | 24 $\frac{5}{8}$ " | 4" | 10 |
| DC-P-55-CANF-UF-BU** | BLUE | 24 $\frac{5}{8}$ " | 4" | 10 |
| 30 GALLON DRUMS | | | | |
| DC-P-30-CAN-BK* | BLACK | 20" | 4" | 7 |
| DC-P-30-CAN-BU* | BLUE | 20" | 4" | 7 |
| DC-P-30-CANF-BK* | BLACK | 20" | 4" | 7 |
| DC-P-30-CANF-BU* | BLUE | 20" | 4" | 7 |

model
CAN-CAP-Pmodel
DC-P-55-CAN-BKmodel
DC-P-55-CAN-BU

New



series FTT

series TRASH-TOP

series TRASH-TOP-DD

48 Hours
to Ship

POWDER
COATED
TOUGH

New

Waste Disposal Tops for Drums

Convert empty drums into waste recycling, general, or disposal containers. Spring-loaded front door closes automatically to prevent bugs and bees from entering. Fits standard 55 gallon steel drum, 23½" outside diameter. Secures to drum top with set screws. Baked-in powder-coat toughness except for TRASH-TOP-ZGY, which is zinc-plated with a gray baked-in powder-coated finish for toughness and superior corrosion protection.

| MODEL NUMBER | MATERIAL | COLOR | OVERALL SIZE (H x D) | WEIGHT (POUND) |
|--------------------------------------|------------|-----------|--|----------------|
| SINGLE DOOR | | | | |
| TRASH-TOP-RD | STEEL | RED | 10¾" x 24½" | 13 |
| TRASH-TOP-GN | STEEL | GREEN | 10¾" x 24½" | 13 |
| TRASH-TOP-BK | STEEL | BLACK | 10¾" x 24½" | 13 |
| TRASH-TOP-ZGY | STEEL | GRAY | 10¾" x 24½" | 13 |
| FTT-RD | FIBERGLASS | RED | 11 ¹⁵ / ₁₆ " x 25" | 8 |
| FTT-GN | FIBERGLASS | GREEN | 11 ¹⁵ / ₁₆ " x 25" | 8 |
| FTT-BK | FIBERGLASS | BLACK | 11 ¹⁵ / ₁₆ " x 25" | 8 |
| SINGLE DOOR - (3) THREE PACKS | | | | |
| TRASH-TOP-RD-3PK | STEEL | RED | 10¾" x 24½" | 13 |
| TRASH-TOP-GN-3PK | STEEL | GREEN | 10¾" x 24½" | 13 |
| TRASH-TOP-BK-3PK | STEEL | BLACK | 10¾" x 24½" | 13 |
| TRASH-TOP-ZGY-3PK* | STEEL | ZINC/GRAY | 10¾" x 24½" | 13 |
| DUAL DOOR | | | | |
| TRASH-TOP-DD-RD | STEEL | RED | 10¾" x 24½" | 14 |
| TRASH-TOP-DD-GN | STEEL | GREEN | 10¾" x 24½" | 14 |
| TRASH-TOP-DD-BK | STEEL | BLACK | 10¾" x 24½" | 14 |
| TRASH-TOP-DD-ZGY* | STEEL | ZINC/GRAY | 10¾" x 24½" | 14 |
| DUAL DOOR - (3) THREE PACKS | | | | |
| TRASH-TOP-DD-RD-3PK | STEEL | RED | 10¾" x 24½" | 14 |
| TRASH-TOP-DD-GN-3PK | STEEL | GREEN | 10¾" x 24½" | 14 |
| TRASH-TOP-DD-BK-3PK | STEEL | BLACK | 10¾" x 24½" | 14 |
| TRASH-TOP-DD-ZGY-3PK* | STEEL | ZINC/GRAY | 10¾" x 24½" | 14 |

*ZINC PLATED WITH GRAY TOP COAT



model
DCVR-55-E



model
DCVR-GBEC

Elastic Drum Covers

Polyethylene Elastic Drum Covers protect in-plant or packaged products from outside contaminants such as water, grease, dust, and other outside elements. These low density poly covers are used for covering and protecting drums and containers that are packaging products such as foods, chemicals, pharmaceuticals, as well as many other industrial packaging applications.

| MODEL NUMBER | ACCEPTABLE DRUM SIZES | TYPE | THICKNESS | CASE QTY. | WEIGHT (POUND) |
|--------------|-----------------------|----------------------|-----------|-----------|----------------|
| DCVR-30-E | 30 GALLON | LOW DENSITY POLY | 4 MIL | 100 | 8 |
| DCVR-55-E | 55 GALLON | LOW DENSITY POLY | 4 MIL | 100 | 12 |
| DCVR-30-E-AS | 30 GALLON | LOW DENSITY ANTISTAT | 4 MIL | 100 | 8 |
| DCVR-55-E-AS | 55 GALLON | LOW DENSITY ANTISTAT | 4 MIL | 100 | 12 |
| DCVR-GBEC | GAYLORD BOX | LOW DENSITY POLY | 4 MIL | 25 | 14 |



48 Hours
to Ship

Drum Lid Tool

Finally an answer for opening those stubborn lids! Multi-purpose design for use with removable head steel drums. A special hook is used for breaking open-lid seals and a long handle provides adequate torque for easy operation. Integral wrench for use with removable ring bolt and nut. Slotted end used to close drum ring lever lock. Steel construction with a silver baked-in powder-coated toughness.



| MODEL NUMBER | DRUM TYPE | WRENCH OPENING | WEIGHT (POUND) |
|--------------|-----------------------|----------------|----------------|
| DRUM-PLB | REMOVABLE HEAD, STEEL | 1" | 4 |

Drum Bung Nut Wrenches

Bung Nut Wrenches are available in several different materials to meet many applications. These multipurpose drum tools not only open and close drum bungs or plugs, they also work as a bung wrench, ring wrench, and faucet wrench all in one! Wrenches are universal because they fit all types of industrial drum plugs and bungs in metal or plastic. The angled handles on models BNW-I-W and BNW-B-W protect knuckles in most positions. Model BNW-SS-W is made of NSF 51 compliant stainless steel and meets 2009 FDA Food Code requirements for non-food contact equipment. These durable wrenches will not bend, break, or chip. Eliminate the need for extra tools with these multifunctional drum wrenches! Patent pending.



| MODEL NUMBER | DESCRIPTION | OVERALL LENGTH | WEIGHT (POUND) |
|--------------|---|----------------|----------------|
| BNW-A | SPARK RESISTANT ALUMINUM (SINGLE ENDED) | 10½" | 2 |
| BNW-I-W | POLISHED ZINC CAST STEEL | 13" | 5 |
| BNW-B-W | SPARK RESISTANT BRONZE ALLOY | 13" | 5 |
| BNW-IX-W | POLISHED ZINC CAST STEEL | 12" | 2 |
| BNW-BX-W | SPARK RESISTANT BRONZE ALLOY | 12" | 2 |
| BNW-SS-W | STAINLESS STEEL | 12" | 2 |
| BNW-P | SPARK RESISTANT SOLID NYLON-66 | 9⅞" | 2 |

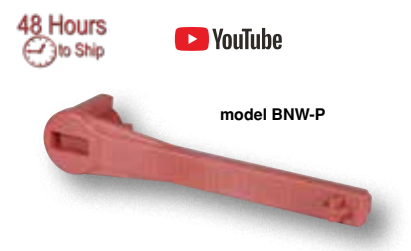

Drum Bung Sockets

Open drum bungs easily! Tighten or remove with a socket wrench (wrench not included). Manufactured from high quality steel alloy for use with impact drive tools. Available in spark resistant bronze alloy or zinc plated cast steel. Fits ¾" and 2" drum plugs.



| MODEL NUMBER | DESCRIPTION | DRIVE SIZE | WEIGHT (POUND) |
|--------------|-------------------------------|------------|----------------|
| BUNG-S-B1 | SPARK RESISTANT BRONZE ALLOY | ¾" | 1 |
| BUNG-S-B2 | SPARK RESISTANT BRONZE ALLOY | ½" | 1 |
| BUNG-S-S1 | BRIGHT ZINC PLATED CAST STEEL | ¾" | 1 |
| BUNG-S-S2 | BRIGHT ZINC PLATED CAST STEEL | ½" | 1 |
| BUNG-S | BRIGHT ZINC PLATED CAST STEEL | ¾" | 1 |



Drum Impact Socket

Designed for opening and closing 2" and ¾" drum plugs. Use with a ½" ratchet drive. Manufactured from heat treated chrome vanadium steel for strength when using with pneumatic impact driver. Works with several ¾" and 2" drum plugs.

| MODEL NUMBER | DESCRIPTION | DRUM SOCKET ACCOMMODATES | RATCHET DRIVE | WEIGHT (POUND) |
|--------------|---------------|--------------------------|---------------|----------------|
| BUNG-X | IMPACT SOCKET | 2" & ¾" | ½" | 2 |





model DVA-B

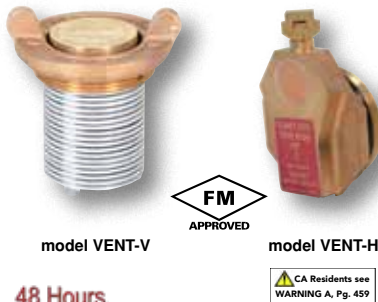

model VENT-V

model VENT-H



model TW-38



model TW-12



model BLD-80



model DTL-22



THE TAP-3 WILL ONLY WORK WITH THIS TYPE OF DRUM PLUG.

Brass Drum Vent Adaptor

Allows for use of 2" drum vents in 3/4" drum plugs. No need to remove drum faucets to use drum vents. Top features 2" female threads. Bottom features 3/4" male threads. Solid brass construction is non-sparking. Drum Vents are sold separately.

| MODEL NUMBER | DESCRIPTION | WEIGHT (POUND) |
|--------------|-------------------------|----------------|
| DVA-B | BRASS DRUM VENT ADAPTOR | 2 |

Drum Vents

Two styles available for use with drums in horizontal or vertical positions. Use with standard 2" drum plug openings. Each vent includes a flash arrestor for safety. FM approved.

| MODEL NUMBER | DESCRIPTION | DISPLACEMENT | WEIGHT (POUND) |
|--------------|------------------------------|------------------|----------------|
| VENT-V | VERTICAL DRUM VENT (BRASS) | FITS 2" OPENINGS | 2 |
| VENT-H | HORIZONTAL DRUM VENT (BRASS) | FITS 2" OPENINGS | 2 |

Torque Wrenches

Reversible ratchet-head style torque wrenches. Easy to set torque setting - wrench 'clicks' when setting is reached. Knurled handle grip surface for extra grip during use. Use with bung sockets to comply with UNC standards.

| MODEL NUMBER | DRIVE SIZE | TORQUE RATING | OVERALL LENGTH | WEIGHT (POUND) |
|--------------|------------|-------------------|----------------|----------------|
| TW-38 | 3/8" | 10 - 80 ft.-lbs. | 15 1/2" | 4 |
| TW-12 | 1/2" | 10 - 150 ft.-lbs. | 18 1/4" | 5 |

Drum Locks

Prevent unauthorized access to drum contents. Simply screw drum lock into place, insert steel rod, and secure with padlock (padlock not included). Steel rod is pre-drilled with a 5/16" diameter padlock hole. Works with both 3/4" and 2" bungs.

| MODEL NUMBER | DESCRIPTION | THREAD DIAMETER | WEIGHT (POUND) |
|--------------|-------------------------|-----------------|----------------|
| BLD-80 | BRASS DRUM LOCK | 2" & 3/4" | 4 |
| DTL-22 | POLYCARBONATE DRUM LOCK | 2" & 3/4" | 2 |

Horizontal Drum Tap

This unique product will allow you to open a 2" drum bung, empty the contents of the drum, and close the drum bung, all with the drum in the horizontal position. Eliminates the need to rotate the drum into the vertical position to gain access. Operation is simple: attach Drum Tap to bung with locking ring, push handle towards drum and twist to unscrew bung, pull handle out away from drum to empty drum contents. Reverse operation to close drum and remove Drum Tap from bung. This product saves time, energy, and reduces the risk of spills. May be used to fill drums in the horizontal position with the bung positioned at the top of the drum. Constructed of fiberglass reinforced polypropylene. O-rings are made of nitrile rubber.

| MODEL NUMBER | DESCRIPTION | ACCOMMODATES | WEIGHT (POUNDS) |
|--------------|---------------------|-----------------|-----------------|
| TAP-3 | HORIZONTAL DRUM TAP | 2" DRUM OPENING | 2 |

Manual Drum Faucets

Quickly and easily dispense drum contents with our Drum Faucets. Available in plastic, stainless steel, aluminum, zinc, and brass.

Polyethylene Drum Faucet, model VDFT, is constructed of corrosion-resistant polyethylene. Handles viscous materials. Instant on/off control ensures fast, smooth flow. Padlock not included. Integral hook allows users to hang pail on faucet (51 pounds).

The Jumbo Drum Faucets, model JDFT, are ideal for dispensing viscous, non-corrosive flammables such as adhesives, paint, heavy oils, grease, and varnish. Padlock not included. Integral hook allows users to hang pail on faucet (51 pounds).



model VDFT
Non-Adjustable Nozzle

CA Residents see
WARNING A, Pg. 459

48 Hours
to Ship



model DFT-SS
Adjustable Nozzle

model DFT-AL
Non-Adjustable Nozzle

model DFT-AS-SC
Non-Adjustable Nozzle

model DFT-RIGID
Non-Adjustable Nozzle

model DFT-ADJ
Adjustable Nozzle

model JDFT-B
Non-Adjustable Nozzle

| MODEL NUMBER | DESCRIPTION | ACCOMMODATES BUNG SIZE | WEIGHT (POUND) |
|--------------|---|------------------------|----------------|
| VDFT*Ⓢ | POLYETHYLENE (MANUAL HANDLE) | 3/4" | 1 |
| VDFT-6PKG*Ⓢ | POLYETHYLENE (MANUAL HANDLE) - 6 PACK | 3/4" | 2 |
| DFT-SSⓈ | STAINLESS STEEL (SPRING-LOADED HANDLE) | 3/4" | 2 |
| DFT-ALⓈ | BRASS-PLATED ALUMINUM (LOCKABLE HANDLE) | 3/4" | 1 |
| DFT-AS-SCⓈ | BRASS-PLATED ZINC (LOCKABLE HANDLE) | 3/4" | 1 |
| DFT-RIGIDⓈ | BRASS (LOCKABLE HANDLE) | 3/4" | 1 |
| DFT-ADJⓈ | BRASS (SPRING-LOADED HANDLE) | 3/4" | 2 |
| JDFT*Ⓢ | JUMBO PLASTIC (MANUAL HANDLE) | 2" | 1 |
| JDFT-6PKG*Ⓢ | JUMBO PLASTIC (MANUAL HANDLE) - 6 PACK | 2" | 6 |
| JDFT-BⓈ | JUMBO BRASS (MANUAL HANDLE) | 2" | 7 |



model JDFT
Non-Adjustable Nozzle



*INCLUDES (3) THREE GASKETS TO FIT DIFFERENT KINDS OF DRUMS.

Horizontal Drum Gauge Level Indicator

The Horizontal Drum Gauge Level Indicator allows personnel to read the level of contents in a drum. Gauge accepts a 3/4" faucet (sold separately). 18 3/8" site gauge. For use with plastic or steel drums. Works well with most oils, solvents, and chemicals. Faucet is not included.

| MODEL NUMBER | DESCRIPTION | DISPLACEMENT | WEIGHT (POUND) |
|--------------|-----------------------|--------------|----------------|
| DGLI-4Ⓢ | HORIZONTAL DRUM GAUGE | 3/4" BUNGS | 3 |



48 Hours
to Ship

Steel Drum Funnel (with self-closing lid)

Allows for quick filling of 55 gallon drums with 2" plug. Includes 8 3/4" long brass flame arrestor for safety. Hinged lid with fusible link automatically closes at 155°. Lid latch may be locked for security (lock not included). Fits 2" NPS threaded drum bung. Gasket included for tight seal. Steel funnel construction with painted finish. Exterior finish is not chemical-resistant and might be damaged by alcohols, e.g. ethanol in fuels. If necessary, apply a chemical-resistant spray coating to the exterior (red) finish before using the funnel.

| MODEL NUMBER | CONSTRUCTION | DRUM SIZE | FITS DRUM BUNGS | WEIGHT (POUND) |
|--------------|--------------|-----------|-----------------|----------------|
| DF-SⓈ | STEEL | 55 GALLON | 2" | 10 |



48 Hours
to Ship

CA Residents see
WARNING A, Pg. 459

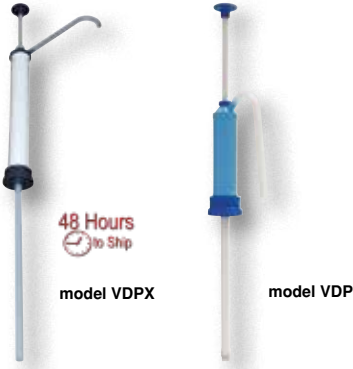

Self-Venting Drum Pumps

Designed for dispensing and transferring liquids out of 55 gallon drums, 5 gallon and 15 gallon pails. Constructed of polypropylene for application specific chemical resistance.

VDP & VDPX - Exceptional resistance to corrosive chemicals (non-flammable solvents). VDP includes a 2 piece dip tube with connector 32" long total.

| MODEL NUMBER | CONSTRUCTION | DISPLACEMENT PER STROKE | BUNG SIZE | WEIGHT (POUND) |
|-------------------|---------------|-------------------------|-----------|----------------|
| VDP [®] | POLYPROPYLENE | 8 oz. | ¾" & 2" | 2 |
| VDPX [®] | POLYPROPYLENE | 16 oz. | ¾" & 2" | 2 |

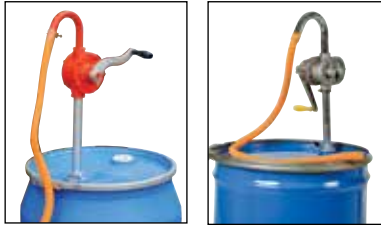

Rotary Drum Pumps

For dispensing and transferring liquids out of 55 gallon drums.

RDP-55 - Ideal for light oils, anti-freeze, and other light non-flammable and non-combustible liquids. Hose included.

ADP-55 - High-speed drum pump for light oils up to 40 weight. Hose included.

RP-90RT - Ideal for soluble, corrosive, volatile, and aggressive chemicals. Suitable for use with Acetone, Ad-Blue and MEK.

RP-90R - For transferring soluble, corrosive, volatile, and aggressive chemicals (esters, alcohols, alkali, acids, hydrocarbons, petroleum based fluid, transmission fluid, and water based chemicals).

RP-90FG - Suitable for most soluble, corrosive, volatile, and liquids which are compatible with PTFE and HFP/TFE.

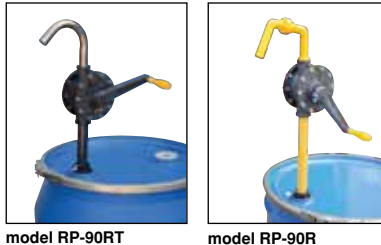

| MODEL NUMBER | CONSTRUCTION | DISPLACEMENT PER STROKE | BUNG SIZE | WEIGHT (POUND) |
|----------------------|--------------|-------------------------|-----------|----------------|
| RDP-55 [®] | STEEL | 11.8 oz. | 2" | 12 |
| ADP-55 [®] | ALUMINUM | 11.8 oz. | 2" | 14 |
| RP-90RT [®] | PPS | 11.8 oz. | 2" | 5 |
| RP-90R [®] | PPS | 11.8 oz. | 2" | 5 |
| RP-90FG [®] | PTFE | 10.14 oz. | 2" | 5 |



Lever Action Drum Pumps

Designed for dispensing and transferring liquids out of 55 gallon drums.

VLDP - Handles viscous liquids up to 12,000 cPs (equivalent to SAE 90 oil). Not for use above 125°F or with heated drums. Includes 35" long dip tube.

LDP-ST - For petroleum products up to 200 cPs.

LDP-SS-316 - Model is hand pumped rather than levered.

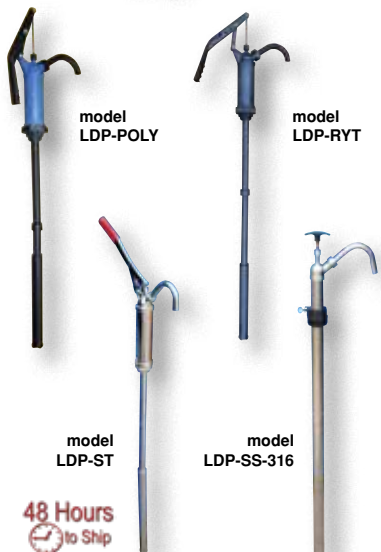

| MODEL NUMBER | CONSTRUCTION | DISPLACEMENT PER STROKE | BUNG SIZE | WEIGHT (POUND) |
|---------------------------|---------------------------------|-------------------------|-----------|----------------|
| VLDP [®] | POLYPROPYLENE | 10 oz. | 2" | 2 |
| LDP-ST [®] | STEEL | 12 oz. | 2" | 5 |
| LDP-POLY [®] | POLYPROPYLENE, PLATED STEEL ROD | 12 oz. | 2" | 4 |
| LDP-RYT [®] | PPS, 316 SS ROD | 12 oz. | 2" | 4 |
| LDP-POLY-304 [®] | POLYPROPYLENE, 304 SS ROD | 12 oz. | 2" | 4 |
| LDP-FG [®] | PTFE, SS PISTON ROD | 12 oz. | 2" | 4 |
| LDP-SS-316 [®] | 316 STAINLESS STEEL | 16 oz. | 2" | 5 |

Electric Drum Pumps 115V 1-PHASE STANDARD

Reduce time required to dispense or transfer liquids. Electric drum pumps allow you to move fluid easily and efficiently. Pumps come complete with tube for 2" bung, hose, and 115V motor.

FHL-PUMP for Flammables & Hazardous Locations

ME I 6 EX motor, Class I Group C&D, Class II Groups F&G (Explosion Proof) with 16 ft. cord, pump tube SS 39" sealless, high volume rotor, 1" SS barrel adaptor, 1" SS nozzle with swivel, 8' conductive chemical tubing with conductive fittings, ground & bonding wires, wall hanger.

ODF-PUMP for Thin-Bodied Oils & Diesel Fuel

B36 motor with 16 ft. cord, pump tube ALU 39" sealless, high head impeller, 316 stainless steel shaft, PP Barrel Adaptor, 1" aluminum nozzle with swivel, 8" PVC hose, hose clamps, and wall hanger.

ABS-PUMP for Acids & Base Solutions

B36 motor with 16 ft cord, pump tube PP 39" sealless, high volume rotor, Hastelloy C shaft, PP barrel adaptor, 3/4" PP nozzle, 8' PVC hose, hose clamps, and wall hanger.

HCB-PUMP for Highly Corrosive Acids & Base Solutions

B55T-5 motor with 16 ft. cord, pump tube PVDF 39" sealless, high volume rotor, Hastelloy C shaft, PP barrel adaptor, 1" PVDF nozzle with swivel, 8' chemical hose, hose clamps, and wall hanger.

| MODEL NUMBER | MAXIMUM VISCOSITY | MAXIMUM CAPACITY | MAXIMUM HEAD | MAXIMUM S.G. | IMMERSION DEPTH | WEIGHT (POUND) |
|------------------|-------------------|------------------|--------------|--------------|-----------------|----------------|
| EDP [Ⓢ] | 400 CPS | 22.75 GPM | 43 FT. | 1.3 | 39" | 20 |
| FHL-PUMP | 500 CPS | 18.5 GPM | 33 FT. | 1.3 | 12" | 21 |
| ODF-PUMP | 500 CPS | 15.9 GPM | 68 FT. | 1.4 | 12" | 21 |
| ABS-PUMP | 600 CPS | 13.5 GPM | 31 FT. | 1.4 | 12" | 18 |
| HCB-PUMP | 500 CPS | 13.5 GPM | 26 FT. | 1.6 | 39" | 35 |



Fire Extinguisher Carrier

The Fire Extinguisher Carrier is designed for easily transporting your fire extinguisher up to 8" in diameter. Includes two (2) heavy duty adjustable rubber straps. Sturdy handle with rubber grip and poly casters for tilt-n-go portability. Welded steel construction with yellow baked-in powder-coat toughness. 4" x 2" stabilizing plate keeps unit upright when empty and helps retain extinguisher. Adjustable EPDM restraining straps keep extinguisher secure and allow for quick access. Wall mount bracket included to store the extinguisher off the floor.

| MODEL NUMBER | OVERALL SIZE (W x L x H) | WHEEL TYPE | WHEEL SIZE | WEIGHT (POUND) |
|--------------------|--|--------------|--------------------------------------|----------------|
| FEC-1 [Ⓢ] | 14 ³ / ₈ " x 11 ¹ / ₈ " x 41 ³ / ₈ " | POLY-ON-POLY | 4" x 1 ¹ / ₄ " | 13 |

48 Hours to Ship



Wall Mounted Cylinder Brackets

Simple design is easy to install. Simply bolt to wall and then secure cylinder with strap. Edges are protected with rubber guards on the steel units. Choose either steel or molded plastic construction. Maximum 12" cylinder diameter. Installation hardware is not included.

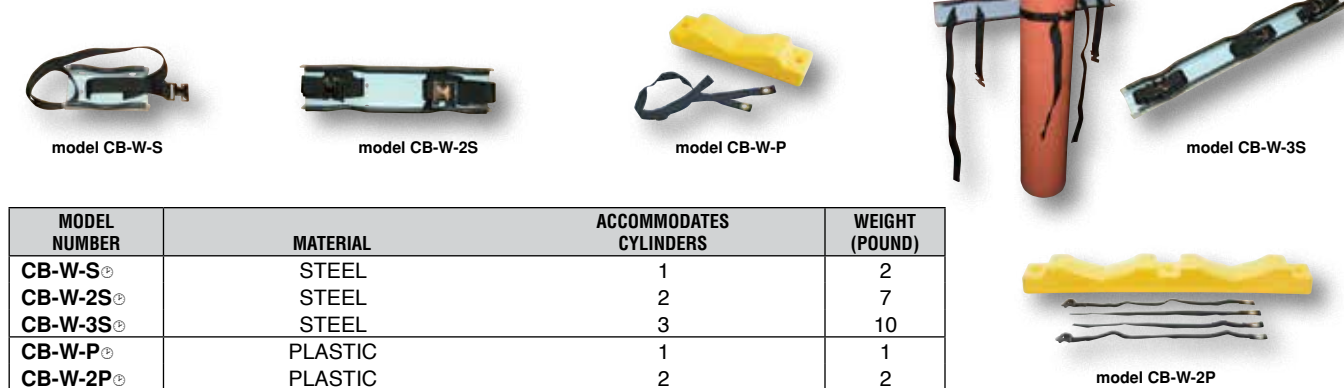

| MODEL NUMBER | MATERIAL | ACCOMMODATES CYLINDERS | WEIGHT (POUND) |
|----------------------|----------|------------------------|----------------|
| CB-W-S [Ⓢ] | STEEL | 1 | 2 |
| CB-W-2S [Ⓢ] | STEEL | 2 | 7 |
| CB-W-3S [Ⓢ] | STEEL | 3 | 10 |
| CB-W-P [Ⓢ] | PLASTIC | 1 | 1 |
| CB-W-2P [Ⓢ] | PLASTIC | 2 | 2 |



model
CYL-W

Wall Mounted Cylinder Holder

The Wall Mounted Cylinder Holder is great for any industrial environment. The cylinder holder keeps cylinders in a defined area for both safety and convenience. The unit is standard with removable straps for securing tanks in place, as well as pre-drilled holes for quick wall mounting and a yellow painted finish for clear visibility.

| MODEL NUMBER | OVERALL SIZE (W x D x H) | UNIFORM CAPACITY | WEIGHT (POUND) |
|--------------|--|------------------|----------------|
| CYL-W | 24 ¹ / ₄ " x 15 ¹³ / ₁₆ " x 66 ³ / ₈ " | 500 lb. | 219 |

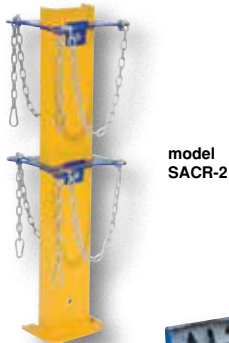

model
SACR-2

Cylinder Storage Stand

A cylinder storage stand is great for additional cylinders that are both used and unused. The sturdy steel construction with a bright yellow and blue finish endorses visibility of the unit, both near and far. Two cylinders are able to be stood in a secure position due to the shaped steel and safety chain. The unit can be secured to the floor by utilizing the pre-drilled mounting holes at the base of the stand.

| MODEL NUMBER | OVERALL SIZE (W x D x H) | CYLINDER CAPACITY | WEIGHT (POUND) |
|--------------|--|-------------------|----------------|
| SACR-2 | 10 ¹ / ₁₆ " x 9 ¹ / ₂ " x 36 ¹ / ₄ " | 2 | 40 |



model CB-S-2S

48 Hours
to Ship

Cylinder Bracket Stands

Our Cylinder Bracket Stands allow for storage of cylinders in the vertical position. The straps are included for securing the cylinders to the stand. Stands have pre-drilled mounting holes for attachment to the floor (floor mounting hardware is not included). Stands are a blue baked-in powder-coated toughness. Steel brackets feature a gray painted finish. Assembly hardware included.

| MODEL NUMBER | OVERALL SIZE (W x D x H) | CYLINDER CAPACITY | WEIGHT (POUND) |
|--------------|--|-------------------|----------------|
| CB-S-2S | 10 ³ / ₄ " x 27" x 30 ³ / ₈ " | 2 | 35 |
| CB-ST-4 | 35 ¹ / ₂ " x 20 ³ / ₄ " x 36 ¹ / ₂ " | 4 | 58 |
| CB-ST-6 | 47 ¹ / ₂ " x 20 ³ / ₄ " x 36 ¹ / ₂ " | 6 | 69 |
| AS-125 | ANCHOR BOLTS FOR CONCRETE (1) 1/2" x 5" | | |
| AS-125-4PK | ANCHOR BOLTS FOR CONCRETE (4) 1/2" x 5" | | |



model CB-ST-6

48 Hours
to Ship

Cylinder Dollies

Transport cylinders up to 11¹/₂" in diameter from workstation to workstation. Nose plate measures 12"W x 15¹/₂"D. The deluxe version, feature roller guides attached to the nose plate. The hard rubber roller guides measure 4" x 1¹/₄". These wheels allow for easier entry onto the nose plate. Secure the cylinder with the included restraint chains. Tilt unit back and transport. Units ships knockdown.

| MODEL NUMBER | OVERALL SIZE (W x L x H) | WHEEL TYPE | WHEEL SIZE | WEIGHT (POUND) |
|----------------|--|-------------|--|----------------|
| DELUXE | | | | |
| CYL-DLX-1-HR | 19" x 26 ¹⁵ / ₁₆ " x 51 ⁵ / ₁₆ " | HARD RUBBER | 10" x 2 ¹ / ₂ " | 71 |
| CYL-DLX-1-PN | 19" x 27 ¹ / ₁₆ " x 51 ⁵ / ₁₆ " | PNEUMATIC | 10 ¹ / ₄ " x 3 ¹ / ₂ " | 86 |
| ECONOMY | | | | |
| CYL-D-1-HR | 15 ³ / ₈ " x 24 ¹⁵ / ₁₆ " x 53 ³¹ / ₃₂ " | HARD RUBBER | 10" x 2 ¹ / ₂ " | 65 |
| CYL-D-1-PN | 16 ⁵ / ₈ " x 25 ¹ / ₁₆ " x 54 ³ / ₃₂ " | PNEUMATIC | 10 ¹ / ₄ " x 3 ¹ / ₂ " | 60 |



model
MCHT-350

Magnetic Cylinder Hand Truck

Designed and built to transport gas cylinders with ease, this hand truck uses strong magnets to hold the tanks in place. Units rolls easily on two (2) 10" x 2¹/₂" rubber tires and two (2) 3" x 1¹/₄" swivel casters. The tilt back design allows for effortless transportation. Baked-in powder-coated toughness.

| MODEL NUMBER | OVERALL SIZE (W x L x H) | UNIFORM CAPACITY | WEIGHT (POUND) |
|--------------|---|------------------|----------------|
| MCHT-350 | 18 ¹¹ / ₁₆ " x 35 ¹ / ₄ " x 50" | 350 lb. | 104 |

Welding Tank Cart

The Welding Tank Cart is a great addition to manufacturing and industrial facilities. The strong steel construction is perfect for transporting and holding single tanks. The included straps allow for safe maneuvering while transporting products. The cart contains a bright yellow finish that promotes visibility in the workplace. For best use, place the cylinder onto the cart in the proper working position. Once in place, increase the tension of the straps around the unit until the tank is secured.

| MODEL NUMBER | OVERALL SIZE (W x L x H) | USABLE WIDTH | MAXIMUM CYLINDER | UNIFORM CAPACITY | WEIGHT (POUND) |
|--------------|---|---------------------------------|------------------|------------------|----------------|
| WTC-1 | 18 ¹¹ / ₁₆ " x 13 ¹ / ₈ " x 57 ⁷ / ₁₆ " | 9 ⁵ / ₈ " | 10" dia. | 350 lb. | 49 |

model WTC-1

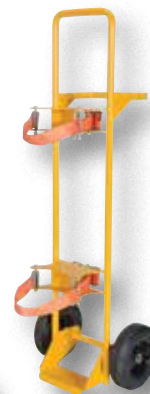
 YouTube

Cylinder Hand Truck

Ideal for transporting cylinders from storage to work space. Tilt back design for effortless transportation. Chains and contoured back cradle provide utmost safety. The two mounted chains measure 28" long. Unit rolls smoothly on two (2) 10" x 2" mold-on-rubber wheels and two (2) 4" x 1³/₈" phenolic casters.

| MODEL NUMBER | OVERALL SIZE (W x L x H) | NOSE PLATE (W x D) | UNIFORM CAPACITY | WEIGHT (POUND) |
|--------------|--|---------------------------------------|------------------|----------------|
| CYHT-350 | 30 ¹ / ₂ " x 17" x 47" | 25 ¹ / ₂ " x 7" | 350 lb. | 84 |

 48 Hours to Ship

model CYHT-350

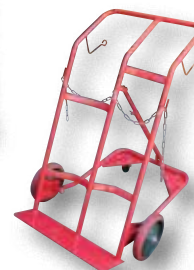

Cylinder Hand Truck

Fold-down single cylinder hand truck are designed and built to transport gas cylinders with ease. Tilt back design for effortless transportation. Fold-down hand trucks are designed to carry cylinder loads on 4-wheel base, thus minimizing operator fatigue and risk. Gas cylinder hand trucks hold cylinders up to 12". Chains and contoured back cradle provide utmost safety. Fold-down trucks are designed for quick, easy, and safe movement of most types of gas cylinders. Units roll on two (2) 8" x 1¹/₂" and two (2) 3" x 1¹/₈" poly-on-poly wheels with brakes.

| MODEL NUMBER | CYLINDER QUANTITY | CAPACITY (POUNDS) | CYLINDER DIAMETER | OVERALL SIZE (W x L x H) | WEIGHT (POUND) |
|--------------|-------------------|-------------------|---|--|----------------|
| CYL-S-FDT | SINGLE | 265 lb. | 5 ¹ / ₂ " to 11 ⁷ / ₈ " | 16 ¹ / ₄ " x 39 ¹ / ₂ " x 34 ¹ / ₂ " | 45 |

 POWDER COATED TOUGH

 48 Hours to Ship

Welding Cylinder Carts

Our Welding Cylinder Carts are ideal for transporting cylinders from storage to work space. Model *CYHT-1* is capable of handling two (2) 9" cylinders. Model *CYHT-2* accommodates one 9" and one 12" cylinder and includes a convenient open-top storage tray. Cylinders are secured in the cart with a ³/₁₆" double twist chain. Chains provide utmost safety. Tilt back design for effortless transportation. Welded steel construction with a baked-in powder-coated toughness.

 New

 48 Hours to Ship

| MODEL NUMBER | WHEEL TYPE | CYLINDER CAPACITY | UNIFORM CAPACITY | WEIGHT (POUND) |
|--------------|---------------|--------------------------|------------------|----------------|
| CYHT-1 | MOLDED RUBBER | 2 @ 9" diameter | 150 lb. | 82 |
| CYHT-2 | FOAM FILLED | 1 @ 9", 1 @ 12" diameter | 250 lb. | 109 |



model CYHT-1



model CYHT-2

Manual Cylinder Lifters

Manual Cylinder Lifters are easy to use and allow for safely lifting cylinders. The pivoting design grabs and squeezes the cylinder when lifted. Lifters feature a rubber-coated center and handle holes. Straight lift with one person or use for a 2 person team lift. Steel construction with a yellow baked-in powder-coated toughness. Uniform capacity is 200 pounds.

| MODEL NUMBER | CYLINDER SIZE | COLOR | WEIGHT (POUND) |
|--------------|---------------|--------|----------------|
| CYL-M-7 | 7" DIAMETER | YELLOW | 8 |
| CYL-M-9 | 9" DIAMETER | YELLOW | 9 |
| CYL-M-10 | 10" DIAMETER | YELLOW | 10 |



model CYL-M-7

 48 Hours to Ship



series CYL-LT

48 Hours
to Ship



model CYL-HLT

Portable Cylinder Lifters

Easily move and lift cylinders for placement into portable welders. Lift cylinders up to 14" high. For use with maximum cylinder height of 56" and a maximum cylinder diameter of 11½". Cylinder is secured to cart with manual ratchet strap. Cylinder is raised and lowered with manual hand crank cable winch. Portable with two (2) 10" wheels. Steel construction with yellow baked-in powder-coated toughness. Uniform capacity is 300 pounds.

| MODEL NUMBER | OVERALL SIZE (W x D x H) | WHEEL TYPE | WHEEL SIZE | WEIGHT (POUND) |
|--------------------------|---|-------------|---------------|----------------|
| CYL-LT-1-HR [®] | 17 ⁵ / ₈ " x 23 ³ / ₈ " x 79 ⁵ / ₁₆ " | HARD RUBBER | (2) 10" x 2½" | 106 |
| CYL-LT-1-PN [®] | 17 ⁵ / ₈ " x 23 ³ / ₈ " x 79 ⁵ / ₁₆ " | PNEUMATIC | (2) 10" x 3½" | 102 |

Cylinder Lifter/Transporter

Perfect for transporting gas cylinders and loading them onto a truck. This unit raises cylinders by simply turning a mechanical hand crank to the desired height. Cylinder is held in place with a tough polyester webbing strap that guards against damage and slipping. Maximum cylinder diameter 11½" by 56" tall.

| MODEL NUMBER | OVERALL SIZE (W x L x H) | HEIGHT TO BOTTOM OF CYLINDER | UNIFORM CAPACITY | WEIGHT (POUND) |
|--------------|---|------------------------------|------------------|----------------|
| CYL-HLT | 37 ¹ / ₃₂ " x 48 ¹⁵ / ₁₆ " x 85 ²⁹ / ₃₂ " | 40" | 300 lb. | 305 |



model CYL-E



model CYL-EH-FP



model CYL-2



TORCH BOX



48 Hours
to Ship

CA Residents see
WARNING A, Pg. 459



model CYL-2-FF



model CYL-2-G



Raise with hoist, lift with fork truck, or manually push around.

Welding Cylinder Torch Carts

Designed for transporting cylinders and cutting torch. Includes two (2) tank compartments with heavy-duty ratchet straps. Brackets are included for holding cutting torch and hose. Sturdy handles and large 16" diameter wheels for tilt-n-go portability. Heavy-duty uniform capacity rating is 500 pounds. Convenient open-top storage tray included on all CYL-E series carts only. CYL-2 models include lockable storage box for regulators. Box includes hose opening so regulator does not need to be disconnected for storage. Lifting eye is 2" maximum diameter, material thickness is 7/16". Fork pockets for transportation is included on CYL-2 models. Usable size of each fork pocket is 7½"W x 2³/₁₆"H. Units with fire protection include ½" (approximately 13mm) marineite 1 material, which provides a 30 minute fire protection barrier as described by OSHA standards 1910.253 and 1926.350. Welded steel construction with a yellow, baked-in powder-coated toughness. Not designed for use as a storage means for gas cylinders.

Models CYL-2-G & CYL-2-FF-G feature a hot dipped galvanized finish.

| MODEL NUMBER | WHEEL TYPE | CUTTING TORCH BOX | OVERHEAD LIFT EYE | FORK POCKETS | OVERALL SIZE (W x L x H) | FIRE PROTECTION | WEIGHT (POUND) |
|---------------------------|-------------|-------------------|-------------------|--------------|--|-----------------|----------------|
| CYL-E [®] | PNEUMATIC | NO | NO | NO | 34½" x 23" x 57" | NO | 144 |
| CYL-E-FF [®] | FOAM-FILLED | NO | NO | NO | 34½" x 22 ¹³ / ₁₆ " x 57" | NO | 150 |
| CYL-EH [®] | PNEUMATIC | NO | YES | NO | 34½" x 23" x 66 ³ / ₈ " | NO | 172 |
| CYL-EH-FF [®] | FOAM-FILLED | NO | YES | NO | 34½" x 22 ¹³ / ₁₆ " x 66 ³ / ₈ " | NO | 185 |
| CYL-EH-FP [®] | PNEUMATIC | NO | YES | NO | 34½" x 23" x 66 ³ / ₈ " | YES | 194 |
| CYL-EH-FP-FF [®] | FOAM-FILLED | NO | YES | NO | 34½" x 22 ¹³ / ₁₆ " x 66 ³ / ₈ " | YES | 224 |
| CYL-2 [®] | PNEUMATIC | YES | YES | YES | 40¼" x 34 ⁹ / ₁₆ " x 66 ³ / ₈ " | NO | 278 |
| CYL-2-FF [®] | FOAM-FILLED | YES | YES | YES | 40¼" x 34 ³ / ₈ " x 66 ³ / ₈ " | NO | 306 |
| CYL-2-FP [®] | PNEUMATIC | YES | YES | YES | 40¼" x 34 ⁹ / ₁₆ " x 66 ³ / ₈ " | YES | 305 |
| CYL-2-FP-FF [®] | FOAM-FILLED | YES | YES | YES | 40¼" x 34 ³ / ₈ " x 66 ³ / ₈ " | YES | 336 |
| CYL-2-G [®] | PNEUMATIC | YES | YES | YES | 40¼" x 34 ⁹ / ₁₆ " x 66 ³ / ₈ " | NO | 275 |
| CYL-2-FF-G [®] | FOAM-FILLED | YES | YES | YES | 40¼" x 34 ³ / ₈ " x 66 ³ / ₈ " | NO | 302 |

Portable Cylinder Clutcher

Designed for lifting and moving gas cylinders with automatic operation. Simply raise and lower handle to operate. Unit raises cylinders 2" off the ground. Works with cylinder diameters between 8½" to 12½". Includes one (1) 5" x 2" swivel with brake, poly on steel back caster and two (2) 8" x 2" rigid, glass filled nylon casters. Welded steel construction with painted yellow finish.

| MODEL NUMBER | OVERALL SIZE (W x L x H) | UNIFORM CAPACITY | ACCOMMODATES CYLINDERS | WEIGHT (POUND) |
|--------------------|---|------------------|------------------------|----------------|
| OCC-2 [Ⓢ] | 32 ¹⁵ / ₁₆ " x 28 ⁵ / ₁₆ " x 53 ³ / ₈ " | 200 lb. | 8½" to 12½" | 162 |



48 Hours
to Ship



model OCC-2

Cylinder Caddies

Transport cylinders safely with casters, overhead lifting assembly, fork mounted, or pallet jack style cylinder caddies. These units can hold anywhere from 2 to 8 cylinders and come complete with safety chains to secure the cylinders in place. Made of all steel construction, these units hold cylinders up to 9½" in diameter. Includes web ratchet retaining strap and edge lip for added safety.

| MODEL NUMBER | USE WITH | UNIFORM CAPACITY | NUMBER OF CYLINDERS | WEIGHT (POUND) |
|---|--------------|------------------|---------------------|----------------|
| CYLINDER CADDIES (NO CASTERS) | | | | |
| CYL-P-4 | FORK TRUCK | 800 lb. | 4 | 173 |
| CYL-P-6 [Ⓢ] | FORK TRUCK | 800 lb. | 6 | 188 |
| CYL-P-8 | FORK TRUCK | 800 lb. | 8 | 231 |
| PJ-CYL-2* | PALLET TRUCK | 400 lb. | 2 | 49 |
| PJ-CYL-4* | PALLET TRUCK | 600 lb. | 4 | 90 |
| CYLINDER CADDIES WITH 4" POLY SWIVEL WITH LOCK CASTERS (BOLT-ON) | | | | |
| CYL-TRUCK-4 | FORK TRUCK | 800 lb. | 4 | 212 |
| CYL-TRUCK-6 | FORK TRUCK | 800 lb. | 6 | 278 |
| CYL-TRUCK-8 | FORK TRUCK | 800 lb. | 8 | 297 |
| CYLINDER CADDIES WITH 4" POLY, TWO (2) SWIVEL WITH LOCK, TWO (2) RIGID (BOLT-ON) | | | | |
| PJ-TRUCK-2 | ---- | 400 lb. | 2 | 88 |
| PJ-TRUCK-4 | ---- | 600 lb. | 4 | 139 |
| CYLINDER CADDIES WITH OVERHEAD LIFTING ASSEMBLY | | | | |
| CYL-P-4-LUG | FORK TRUCK | 800 lb. | 4 | 223 |
| CYL-P-6-LUG | FORK TRUCK | 800 lb. | 6 | 228 |
| CYL-P-8-LUG | FORK TRUCK | 800 lb. | 8 | 281 |

*RETROFIT CASTER OPTION AVAILABLE. model PJ-CYL-CK (4" POLY, TWO (2) SWIVEL W/ LOCK, TWO (2) RIGID, BOLT-ON)



model PJ-CYL-4



model PJ-TRUCK-4

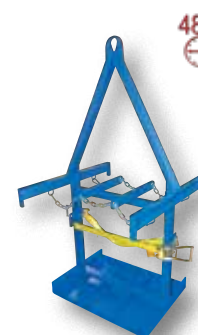

model CYL-P-6-LUG



model CYL-TRUCK-6
FEATURES BOLT-ON
CASTERS

LP Tank Lifter

The LP Tank Lifter is a great addition to manufacturing and maintenance facilities. The lifter is constructed of steel, with a baked-in powder-coated toughness, for supreme strength and durability throughout daily use. The unit also contains a bright finish for both security and discernibility, both indoors and out. To use, simply attach the lifter to a lifting device, such as a fork truck, by utilizing the centrally located chain/hook opening. Once the unit is secured, place the arms tightly under the top and base ridges of the LP tank, lift to the desired height, and transport to the preferred location.

| MODEL NUMBER | OVERALL SIZE (W x L x H) | ACCOMMODATES DIAMETERS | UNIFORM CAPACITY | WEIGHT (POUND) |
|---------------------|---|------------------------|------------------|----------------|
| BTX-LP [Ⓢ] | 34 ⁵ / ₁₆ " x 7 ⁷ / ₈ " x 15 ³ / ₁₆ " | 25" to 30" | 200 lb. | 13 |

48 Hours
to Ship



POWDER
COATED
TOUGH

Fork Truck LP Tank Caddy

Holds up to six (6) LP tanks up to 12" in diameter each. Made of all steel construction. Safety chains to hold the tanks in place are standard. Portable with fork truck. Optional caster kit available, *CYL-CK*.

| MODEL NUMBER | OVERALL SIZE (W x L x H) | ACCOMMODATES CYLINDERS | WEIGHT (POUND) |
|--------------|--|-------------------------|----------------|
| LP-170 | 38½" x 39½" x 29" | 12" DIAMETER x 24" HIGH | 258 |
| CYL-CK | FOUR (4) SWIVEL POLY CASTERS WITH LOCK | | 23 |

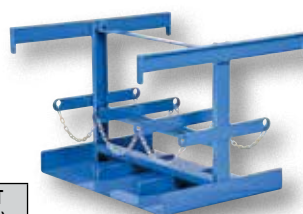

POWDER
COATED
TOUGH



model CYL-H-4-KD



model CYL-V-510



model CYL-H-8



model CYL-LP-8-CA



model CYL-LP-4-CA

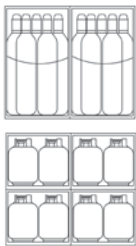

Cylinder Storage Cabinets (only for sale in the USA)

Steel cabinets for storage of cylinders. Cylinder storage capacity is based on cylinder size. Sides and door are made of expanded steel, and the bottom, back, and top are made of solid sheet steel. Lockable doors protect cylinders (padlock not included). Base includes lag holes for securing cabinets. Vertical units include chains for securing cylinders. Includes red lettered signage noting "FLAMMABLE NO SMOKING". Meets OSHA sec. 1910.110 (f)(6)(ii), ANSI NFPA 55 + 58, and CGA P-1 design standards. Rugged steel construction with safety yellow baked-in powder-coated toughness.

| MODEL NUMBER | CYLINDER CAPACITY | OVERALL SIZE (W x L x H) | TYPE | WEIGHT (POUND) |
|---|-------------------|--------------------------|-------------|----------------|
| HORIZONTAL STORAGE CABINETS | | | | |
| CYL-H-4-KD | 4 | 30" x 32" x 35¼" | UNASSEMBLED | 234 |
| CYL-H-8-KD | 8 | 30" x 32" x 68¼" | UNASSEMBLED | 341 |
| CYL-H-12-KD | 12 | 45" x 32" x 68¼" | UNASSEMBLED | 358 |
| CYL-H-16-KD | 16 | 60" x 32" x 68¼" | UNASSEMBLED | 495 |
| CYL-H-4 | 4 | 30" x 32" x 35¼" | ASSEMBLED | 181 |
| CYL-H-8 | 8 | 30" x 32" x 68¼" | ASSEMBLED | 277 |
| CYL-H-12 | 12 | 45" x 32" x 68¼" | ASSEMBLED | 358 |
| CYL-H-16 | 16 | 60" x 32" x 68¼" | ASSEMBLED | 527 |
| VERTICAL STORAGE CABINETS | | | | |
| CYL-V-4 | 4 | 30" x 32" x 35¼" | ASSEMBLED | 220 |
| CYL-V-510 | 5-10 | 30" x 32" x 68¼" | ASSEMBLED | 287 |
| CYL-V-1020 | 10-20 | 60" x 32" x 68¼" | ASSEMBLED | 456 |
| CYL-V-4-KD | 4 | 30" x 32" x 35¼" | UNASSEMBLED | 220 |
| CYL-V-510-KD | 5-10 | 30" x 32" x 68¼" | UNASSEMBLED | 287 |
| CYL-V-1020-KD | 10-20 | 60" x 32" x 68¼" | UNASSEMBLED | 456 |
| HORIZONTAL/VERTICAL STORAGE CABINETS | | | | |
| CYL-H8-V510 | 8H/10V | 60" x 32" x 68¼" | ASSEMBLED | 505 |
| CYL-H8-V510-KD | 8H/10V | 60" x 32" x 68¼" | UNASSEMBLED | 505 |

Cylinder Storage Cabinets (only for sale in CANADA)

Durable steel cabinets for storage of cylinders. Cylinder storage capacity is based on cylinder size. Sides and door are made of expanded steel, and the bottom, back, and top are made of solid sheet steel. Lockable doors protect cylinders (padlock not included). Base includes lag holes for securing unit to floor (hardware is not included). Vertical units include chains for securing cylinders. Includes red lettered signage noting "No Smoking" message in English and French. Meets CSA B-149.2 and OSHA 1910.110 (f)(6)(ii) design standards. Rugged welded steel construction with safety yellow baked-in powder-coated toughness. All units shipped fully assembled.

| MODEL NUMBER | CYLINDER CAPACITY | OVERALL SIZE (W x L x H) | NUMBER OF SHELVES | WEIGHT (POUND) |
|---------------------------------|-------------------|--------------------------|-------------------|----------------|
| LP CYLINDER STYLE | | | | |
| CYL-LP-2-CA | 2 | 30" x 20" x 35¼" | 0 | 136 |
| CYL-LP-4-CA | 4 | 30" x 32" x 35¼" | 0 | 172 |
| CYL-LP-8-CA | 8 | 30" x 32" x 68¼" | 1 | 242 |
| CYL-LP-16-CA | 16 | 60" x 32" x 68¼" | 2 | 452 |
| OTHER GAS CYLINDER STYLE | | | | |
| CYL-G-8-CA | 8 | 30" x 32" x 68¼" | 0 | 206 |
| CYL-G-12-CA | 12 | 60" x 32" x 68¼" | 0 | 432 |

Galvanized Cylinder Storage Cabinets

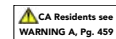

Store LP tanks horizontally and acetylene tanks vertically in these heavy-duty Cylinder Storage Cabinets. Made of all steel construction, these rust resistant units have 4 gauge galvanized welded wire sides with sturdy 1½" square steel angle frames. Durable 12 gauge galvanized steel roof. The galvanized rust resistant finish stands up to harsh outdoor environments. Features a padlock hasp for security (padlock not included), "Danger Flammable Materials" sign, and all necessary hardware. Meets OSHA 1910.110 requirements. Assembly required.



model CYL-T-COMBO

| MODEL NUMBER | CYLINDER CAPACITY | OVERALL SIZE (W x L x H) | WEIGHT (POUND) |
|-------------------------------------|-------------------------|--------------------------|----------------|
| HORIZONTAL STORAGE CABINETS | | | |
| CYL-T-4 | 4 HORIZONTAL | 29" x 29" x 40" | 188 |
| CYL-T-8 | 8 HORIZONTAL | 30" x 30" x 64" | 252 |
| CYL-T-16 | 16 HORIZONTAL | 58" x 29" x 64⅜" | 385 |
| VERTICAL STORAGE CABINETS | | | |
| CYL-T-10 | 9 VERTICAL | 30½" x 30½" x 64⅜" | 211 |
| CYL-T-20 | 18 VERTICAL | 60½" x 30½" x 64½" | 303 |
| COMBINATION STORAGE CABINETS | | | |
| CYL-T-COMBO | 8 HORIZONTAL/9 VERTICAL | 58" x 29" x 66" | 344 |

Propane Exchange Cylinder Cabinets

Durable steel Propane Exchange Cylinder Cabinets for storage of standard propane gas cylinders. The sides are made of expanded steel, and the bottom, back, and top are made of solid sheet steel. Solid steel or expanded metal door available. Lockable door protects cylinders (padlock not included). Each shelf can hold a maximum of six (6) cylinders. White baked-in powder-coated toughness. Includes red lettered signage noting "PROPANE EXCHANGE, FLAMMABLE, NO SMOKING".

| MODEL NUMBER | CYLINDER CAPACITY | OVERALL SIZE (W x L x H) | NUMBER OF SHELVES | WEIGHT (POUND) |
|----------------------------|-------------------|---|-------------------|----------------|
| SOLID STEEL DOOR | | | | |
| CYL-EX-12-S | 12 | 40" x 32 ¹ / ₈ " x 44 ¹ / ₈ " | 1 | 343 |
| CYL-EX-18-S | 18 | 40" x 32 ¹ / ₈ " x 68 ¹ / ₄ " | 2 | 353 |
| EXPANDED METAL DOOR | | | | |
| CYL-EX-12-E | 12 | 40" x 32 ¹ / ₈ " x 44 ¹ / ₈ " | 1 | 301 |
| CYL-EX-18-E | 18 | 40" x 32 ¹ / ₈ " x 68 ¹ / ₄ " | 2 | 393 |



model CYL-EX-12-S



model CYL-EX-18-E

LP Tank Truck

Finally an easy answer to lifting, storing, and transporting problems associated with LP tanks. The built-in crane can be used to safely load full tanks into fork trucks. The crane pivots 360° for maximum versatility. The crane boom is raised and lowered with a manual hand pump hydraulic lift. The tank attachment at the end of the boom automatically clamps to each end of the cylinder. The built-in racks are ideal for LP tank storage-racks. Store two (2) tanks in the vertical position and four (4) tanks in the horizontal position. Unit includes a push handle with two (2) rigid and two (2) swivel with brake casters for portability. Welded steel construction with a painted finish.

| MODEL NUMBER | STORAGE CAPACITY | OVERALL SIZE (W x L x H) | CASTER SIZE AND TYPE | WEIGHT (POUND) |
|--------------|------------------|--|----------------------|----------------|
| LP-6 | 6 TANKS | 33 ¹³ / ₁₆ " x 137 ⁹ / ₁₆ " x 97 ¹¹ / ₁₆ " | 8" x 2" GFN* | 775 |

*GLASS-FILLED NYLON



model LP-6

Aerosol Can Recycle System

Turn aerosol cans into scrap metal, exempting them from disposal regulations for hazardous waste. This system safely punctures aerosol cans to relieve pressure and then empties any residual contents into your drum. Thread the recycler body into the 2" diameter threaded bung and the filter into the 3/4" bung of your 30 or 55 gallon steel or poly drum. Push the lever to puncture the can, and two piece filter with a carbon cartridge drains out odors and harmful emissions. Unit includes puncturing device, safety goggles, carbon filter, and anti-static wire, which prevents static buildup by grounding the drum as required by OSHA.

| MODEL NUMBER | OVERALL SIZE (D x H) | MAXIMUM CAN HEIGHT | MAXIMUM CAN DIAMETER | WEIGHT (POUND) |
|------------------------|---|----------------------------------|----------------------|----------------|
| CAN-RECY [®] | 14 ⁵ / ₁₆ " x 10 ¹ / ₁₆ " | 14 ⁵ / ₈ " | 3" | 9 |
| CAN-R-FLT [®] | REPLACEMENT FILTER | | | 4 |



48 Hours
to Ship

vestil
green

Oil Filter Crushers, *CrushMasters* 208-230V, 1-PHASE STANDARD

Recycle used filters and oil quickly, safely, and easily.

The *CM-1* Oil Filter Crusher operates on normal shop air, delivers over 13,000 pounds of crushing force at 120 PSI, accommodates all standard oil filters, and is designed for high volume use. Will crush up to four (4) automotive spin-on filters at one time. Crushing chamber door is prevented from opening if the ram is in any position other than fully raised. Can be connected to a variety of waste oil containers.

The *CM-2* accommodates standard size filters and heavy-duty truck filters up to 16" high. Convenience and safety features include waste oil drain connections, easily located on/off switch for safe operation, and heavy-duty totally enclosed fan cooled 4HP motor delivering 37,500 pounds of crushing force. Electric-hydraulic operation.

The *Tubular Stand* accommodates model CM-1. Requires 29"W x 22¹/₂"D of floor space. The *Deluxe Stand* accommodates both the CM-1 and CM-2. It is designed with a heavy-duty grated top for drainage of filters before crushing. The floor space required is 29"W x 22³/₈"D. Also allows for placement of 55 gallon drum, sold separately, under crusher to contain oil.

model CM-1
Shown with Tubular Stand,
model CM-Tmodel CM-2
Shown with Deluxe Stand,
model CM-D

| MODEL NUMBER | DESCRIPTION | USABLE SIZE (W x D x H) | OVERALL SIZE (W x D x H) | CYCLE TIME (SECONDS) | WEIGHT (POUND) |
|--------------|-----------------------------------|-------------------------|--|----------------------|----------------|
| CM-1 | AIR OPERATED, 100-180 PSI | 8" x 8" x 9" | 13 ³ / ₄ " x 18" x 27" | 11-20 | 301 |
| CM-2 | ELECTRIC-HYDRAULIC, 208-230V, 1PH | 9" x 9" x 16" | 25" x 27" x 41 ¹ / ₂ " | 12 | 500 |
| CM-T | TUBULAR STAND | -- | 41" HIGH | -- | 120 |
| CM-D | DELUXE STAND | -- | 44" HIGH | -- | 140 |



Aerol Can Crusher

The Aerol Can Crusher uses air bag technology and is 100% air operated with 15 tons of crushing force, enough to shatter the mixing ball. Crushes 2 aerosol cans by 98%. Equipped with a timer and filter regulator gauge, the crusher has a cycle time of 25-60 seconds and requires air input of 120 psi. An outlet valve allows for draining and capturing liquid. Activated carbon filter absorbs contaminants and odors and a fume extractor directs gases outside of area. Greatly reduces disposal costs.

| MODEL NUMBER | DESCRIPTION | OVERALL SIZE (W x L x H) | CYCLE TIME (SECONDS) | WEIGHT (POUND) |
|--------------|-----------------------|--------------------------|----------------------|----------------|
| CAN-RECY-DLX | AIR OPERATED, 120 PSI | 27½" x 27½" x 55" | 25-60 | 550 |



Pail Lid Closing Press

The Plastic Pail Lid Closing Press quickly and easily secures a cover onto a plastic pail. The lid closure allows for easily pressing lids on plastic pails in a single motion. The 39" long handle provides 14:1 advantage - 50 pounds on handle applies 700 pounds on the pail. The long handle provides leverage, reducing the effort necessary to secure lids to pails. Adjustable height table allows for use with different sized pails. Works with pails from 6" to 22" tall. Compression plate diameter is 16" and is fitted with an adjustable burp plunger. Base frame is predrilled for lagging to the floor (hardware not included). Steel construction with a baked-in powder-coated toughness. Not for use with UN-rated pails for hazardous material shipping.

PLC-CK *Optional Caster Kit* includes four (4) 3" x 1¼" poly swivel stem casters with brake.

| MODEL NUMBER | ACCOMMODATES PAIL SIZES | OVERALL SIZE (W x L x H) | UNIFORM CAPACITY | WEIGHT (POUND) |
|--------------|-------------------------|---|------------------|----------------|
| PLC-P-FM | 2-7 GALLONS | 29 ⁷ / ₈ " x 36 ¹³ / ₁₆ " x 96 ³ / ₁₆ " | 250 lb. | 241 |
| PLC-CK | OPTIONAL CASTER KIT | | | 9 |



Manual Pail Tipper

The back saving Manual Pail Tipper is designed for dispensing 5 gallon plastic or steel pails. Variable height chime lock for quick loading and unloading. Sturdy steel or stainless steel construction available. The overall size is 14³/₈"W x 14¹/₄"D x 32³/₁₆"H. Ships knockdown. Some assembly required. Pail is rotated manually.

| MODEL NUMBER | CONSTRUCTION | DISPENSING HEIGHT | UNIFORM CAPACITY | WEIGHT (POUND) |
|--------------|-----------------|-------------------|------------------|----------------|
| CAN-A | STEEL | 10" | 70 lb. | 11 |
| CAN-S | STAINLESS STEEL | 10" | 70 lb. | 12 |

model CAN-A **48 Hours to Ship** model CAN-S



Variable Height Pail Dispensers

Variable Height Pail Dispensers provide 24 angle settings for dispensing 5 gallon, 11" diameter, plastic or steel pails. Dispense at any height between 1" and 52" by turning the hand cable winch. Steel construction with a baked-in powder-coated toughness.

Model LLW-PAILD-100, 4" poly-on-poly rear swivel casters with total lock and 2" steel front rigid casters. Model LLW-PAILD-100-SS, is a stainless steel construction.

Model LLW-PAILD-200, 6" rigid poly-on-poly wheels with tilt back "hand truck" design can go virtually anywhere. Includes 2" diameter front steel wheels and 4" rigid poly-on-poly top wheels.

| MODEL NUMBER | POUR HEIGHT LOWERED / RAISED | CRADLE HEIGHT LOWERED / RAISED | UNIFORM CAPACITY | WEIGHT (POUND) |
|------------------|------------------------------|---|------------------|----------------|
| LLW-PAILD-100 | 1" TO 52" | 6" TO 62¾" | 125 lb. | 139 |
| LLW-PAILD-200 | 1" TO 52" | 7 ¹ / ₈ " TO 62¾" | 200 lb. | 131 |
| LLW-PAILD-100-SS | 1" TO 52" | 6" TO 62¾" | 125 lb. | 139 |

model LLW-PAILD-100 model LLW-PAILD-200

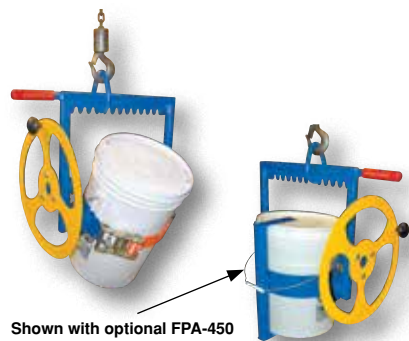

Hoist Mounted Pail Carrier / Rotator

The Hoist Mounted Pail Carrier/Rotator works with both plastic and metal pails. For use with 5, 6, and 6½ gallon pails. It has an adjustable upper bail for easy balancing and allows the user to accurately control and empty pails. 3:1 gear ratio makes for effortless tipping of pails. Meets ANSI B30.20 standard for overhead lifting. A ratcheting nylon harness securely holds the pail in any position. Blue and yellow baked-in powder-coated toughness.

FPA-450 *Optional Mixer Adaptor Arm* allows pails to rotate 360° for mixing of contents.

| MODEL NUMBER | ACCOMMODATES PAIL SIZES | UNIFORM CAPACITY | WEIGHT (POUND) |
|--------------|----------------------------|------------------|----------------|
| PCT-5 | 5, 6, 6½ GALLONS | 200 lb. | 28 |
| FPA-450 | OPTIONAL MIXER ADAPTOR ARM | | 3 |

Shown with optional FPA-450 Mixer Adaptor Arm

Pail Dolly

A pail dolly is a great accessory for the home or the workshop by delivering a more ergonomically friendly way to transfer products. Instead of lifting heavy pails, which can put stress on joints and muscles, this unit can be pushed and steered to the designated location. A large weight capacity and a 5-7 gallon pail accommodation, the user can efficiently move objects in a timely manner while minimizing risk of fatigue. The compact design is easily stored when not in use. Strong construction. Lightweight. Maximizes workload proficiency.



| MODEL NUMBER | ACCOMMODATES PAIL TYPES | OVERALL SIZE (W x H) | UNIFORM CAPACITY | WEIGHT (POUND) |
|--------------|-------------------------|--|------------------|----------------|
| PDD-5 | 5-7 GALLON | 14 ³ / ₄ " x 3 ³ / ₄ " | 80 lb. | 3 |

Ergonomic Elevated Bucket & Pail Dolly

Unique dolly features elevated bucket/pail platform for better ergonomic position. Elevated platform allows for better posture during use, which leads to less fatigue and strain. For use with maximum 10⁹/₁₆" diameter round buckets. Also works with square buckets and boxes with maximum size 10⁹/₁₆" x 10⁹/₁₆". Design folds flat easily for storage when not in use. Portable on four (4) swivel poly casters. Steel construction with a yellow baked-in powder-coated toughness.

| MODEL NUMBER | MAXIMUM PAIL SIZE | OVERALL SIZE (W x D x H) | UNIFORM CAPACITY | WEIGHT (POUND) |
|--------------|--|--|------------------|----------------|
| PDOL-26 | 10 ⁹ / ₁₆ " | 29 ³ / ₈ " x 29 ³ / ₈ " x 32 ¹ / ₈ " | 100 lb. | 19 |
| PDOL-DPAN | OPTIONAL PLASTIC DRIP PAN (with mounting brackets) | | | 5 |



model PDOL-26

Multi-Pail Dolly

Move your 5 gallon containers with ease. Ideal for job sites, tile and grout work, janitorial and cleaning tasks, and other industrial uses. Designed to work with round and square 5 gallon pails; plastic or steel. Rolls smoothly with all swivel 3" polyurethane casters. Ground clearance is 1³/₈". All steel construction with a blue baked-in powder-coated toughness. Includes a 4 foot long pull strap.

| MODEL NUMBER | ACCOMMODATES PAIL TYPES | OVERALL SIZE (W x H) | UNIFORM CAPACITY | WEIGHT (POUND) |
|--------------|-------------------------|--|------------------|----------------|
| MPD-5 | 5 GALLON | 16 ¹ / ₁₆ " x 5" | 150 lb. | 15 |



Pail Hand Truck

This Pail Hand Truck allows one person to easily and efficiently move 5 gallon pails or other miscellaneous items. The nose plate can be flipped down and pail retention fingers flipped up in order for this cart to be used as a basic hand truck. Flip the pail retaining fingers down to utilize the pail lifting feature. An arched back allows the pail to fit safely on the hand truck. Units roll smoothly on large 10" x 2¹/₂" diameter wheels. Baked-in powder-coated toughness.

| MODEL NUMBER | NOSE PLATE (W x L) | OVERALL SIZE (W x D x H) | UNIFORM CAPACITY | WEIGHT (POUND) |
|--------------|--|---|------------------|----------------|
| PAIL-T | 10 ³ / ₄ " x 7 ¹ / ₂ " | 20 ⁹ / ₁₆ " x 16 ¹¹ / ₁₆ " x 55 ³ / ₄ " | 500 lb. | 48 |



Steel Pail Pals (PAIL OPENER)

A must-have product for anyone using five gallon plastic and steel pails. The cutter is used to cut a slit in the lid lip of the pail to enable the lid of the plastic pail to be removed. The side guide conveniently slides under the lid lip for easy removal of the lid. The end hook is used to open steel pails. Just hook the lid lip and rotate. The opposite end is used to close and seal the lid by bending the lip back around the steel pail top. Not for UN rated pails.

The PAIL-PAL-UN features the additional torque required to open UN rated pails by hand.

| MODEL NUMBER | ACCOMMODATES PAIL TYPES | OVERALL SIZE (W x L x THICK) | WEIGHT (POUND) |
|--------------|--------------------------|---|----------------|
| PAIL-PAL | 5 GALLON PLASTIC & STEEL | 3 ¹ / ₂ " x 11" x 1" | 2 |
| PAIL-PAL-UN | 5 GALLON PLASTIC & STEEL | 3 ¹ / ₂ " x 11" x 1 ⁷ / ₈ " | 3 |

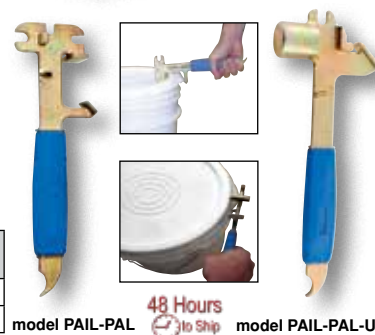

model PAIL-PAL model PAIL-PAL-UN

Steel Pail Lid Closing Tool

Quickly and easily secure steel pail lids onto steel pails with the Steel Pail Lid Closing Tool. Manually crimps and closes 16 lugs in a single motion. Long handles provide leverage, reducing the effort necessary to secure lids to pails. Intended for use with non-UN Vestil Steel Lids and Steel Pails on page I45.

| MODEL NUMBER | ACCOMMODATES PAIL TYPES | NOMINAL DIAMETER | GAUGE RANGE | WEIGHT (POUND) |
|--------------|-------------------------|----------------------------------|-------------|----------------|
| PLC-5 | 5 GALLON STEEL | 11 ¹ / ₄ " | 26 to 29 | 27 |





Hydraulic Pail Crusher 115V 1-PHASE STANDARD

Crush 5 gallon steel pails quickly and easily. Crushes steel pails to approximately 2" high and resets automatically to crush another pail. Reduce storage space and disposal costs. Safety features include: pressure relief valve to prevent overload, door interlock system to prevent the motor from running if the door is unlatched, and mushroom head emergency stop button. Other features include a hydraulic pump that provides 70 second cycle time, 10,000 pounds of crushing force, removable legs for bench top mounting, and 115 volt single phase for "plug in operation". Meets OSHA and JIC standards. Aluminum drip pan, model HPC-DPN, is available for catching any excess liquid that may be expelled during the crushing operation.

| MODEL NUMBER | DESCRIPTION | OVERALL SIZE (W x D x H) | WEIGHT (POUND) |
|----------------------|--------------------|---|----------------|
| HPC-405 | STEEL PAIL CRUSHER | 27" x 22 ³ / ₁₆ " x 67 ⁹ / ₁₆ " | 360 |
| HPC-DPN [®] | ALUMINUM DRIP PAN | 17" x 9" x 2 ¹ / ₄ " | 10 |



Piston Pail Pumps

Designed for dispensing and transferring liquids out of 5 gallon pails.

PAIL-PST - Includes an adaptor to accommodate 2" bungs.

PAIL-PST-SS - Handles most liquids*

*NOT RECOMMENDED FOR: Ammonium Chloride, Aqua Regia, Bromine Water, Calcium Chloride, Chloracetic Acid, Chlorine Water, Ferric Chloride, Ferrous Chloride, Freon 12, Hydrobromic Acid, Hydrofluoric Acid, Sodium Hydroxide, Stannic Chloride, and Sulfuric Acid.

| MODEL NUMBER | CONSTRUCTION | DISPLACEMENT PER STROKE | BUNG SIZE | WEIGHT (POUND) |
|--------------------------|-----------------|-------------------------|-----------|----------------|
| PAIL-PST [®] | STEEL | 8 oz. | 1" | 3 |
| PAIL-PST-SS [®] | STAINLESS STEEL | 8 oz. | 1" | 3 |



Elastic Pail Covers

Polyethylene Elastic Pail Covers protect in-plant or packaged products from outside contaminants such as water, grease, dust, and other outside elements. These low density poly covers are used for covering and protecting drums, pails, and containers that are packaging products such as foods, chemicals, pharmaceuticals, and many more industrial packaging applications.

| MODEL NUMBER | TYPE | THICKNESS | CASE QUANTITY | WEIGHT (POUND) |
|--------------|--------------------------|-----------|---------------|----------------|
| DCVR-5-E | LOW DENSITY POLYETHYLENE | 4 MIL | 100 | 5 |
| DCVR-5-E-AS | LOW DENSITY ANTISTAT | 4 MIL | 100 | 5 |

48 Hours
to Ship



model DLINE-5-15-HD



model DLINE-5-15-LD



model DLINE-5-15-LD-AS



model PAIL-LINE

Pail Liners

Pail Liners make disposing of materials easy, plus they help keep our environment cleaner by ensuring the maximum recovery of product. Liners also save you money by extending the lifetime of pails and reducing the cost to clean and recondition them. All rigid liners are manufactured using prime virgin FDA compliant polyolefin resins. Pails sold separately.

| MODEL NUMBER | TYPE | MATERIAL | DIAMETER | LAY FLAT SIZE (W x H) | THICKNESS | CASE QUANTITY | WEIGHT (POUND) |
|--------------|--------------------|--------------------------|----------------------------------|-----------------------|-----------|---------------|----------------|
| DLINE-5-P | FLEXIBLE PEEL-OVER | LOW DENSITY POLYETHYLENE | 11 ¹ / ₄ " | 18" x 15" | 4 MIL | 500 | 45 |
| DLINE-5-T | FLEXIBLE TIE-OFF | LOW DENSITY POLYETHYLENE | 11 ¹ / ₄ " | 18" x 22" | 4 MIL | 350 | 47 |

| MODEL NUMBER | TYPE | MATERIAL | DIAMETER | HEIGHT | THICKNESS | CASE QUANTITY | WEIGHT (POUND) |
|------------------------|-------|-----------------------------|----------------------------------|--------|-----------|---------------|----------------|
| DLINE-5-15-LD | RIGID | LOW DENSITY POLYETHYLENE | 11 ¹ / ₄ " | 13" | 15 MIL | 100 | 44 |
| DLINE-5-15-HD | RIGID | HIGH DENSITY POLYETHYLENE | 11 ¹ / ₄ " | 13" | 15 MIL | 100 | 44 |
| DLINE-5-15-LD-AS | RIGID | LOW DENSITY ANTISTAT (PINK) | 11 ¹ / ₄ " | 13" | 15 MIL | 100 | 44 |
| PAIL-LINE [®] | RIGID | HIGH DENSITY POLYETHYLENE | 12 ¹ / ₂ " | 13" | 15 MIL | 5 | 2 |

Galvanized, Stainless Steel, & Bronze Buckets

Galvanized and stainless steel buckets are for use in industrial and commercial applications where durability is required. Buckets are nestable and come standard with a carrying handle/bail for easy transport.

BKT-GAL: Galvanized steel, 0.4mm thickness.

BKT-SS: Grade 202 stainless steel. 1mm thickness for 3.25 gallon, 2mm thickness for 5 gallon.

BKT-BRZ-250: Bronze pail is ideal for a variety of settings. The aluminum bronze spark resistant alloy construction works well in hazardous conditions. The pail can be used with a range of materials and surroundings such as petroleum, various chemicals, and mining.



A

B

| MODEL NUMBER | CAPACITY (GALLONS) | CAPACITY (QUARTS) | CAPACITY (POUNDS) | BASE DIAMETER | TOP DIAMETER | WEIGHT (POUND) |
|----------------------------|--------------------|-------------------|-------------------|---------------|--------------|----------------|
| GALVANIZED STEEL | | | | | | |
| A BKT-GAL-325 [Ⓢ] | 3.25 | 13 | 28 | 10" | 12¾" | 3 |
| A BKT-GAL-500 [Ⓢ] | 5 | 20 | 44 | 11¾" | 14¼" | 4 |
| STAINLESS STEEL | | | | | | |
| B BKT-SS-325 [Ⓢ] | 3.25 | 13 | 88 | 8¼" | 12¾" | 4 |
| B BKT-SS-500 [Ⓢ] | 5 | 20 | 57 | 10½" | 15¾" | 8 |
| BRONZE | | | | | | |
| C BKT-BRZ-250 | 2.5 | 10 | 25 | 10¾" | 10½" | 7 |



C

CA Residents see
WARNING A, Pg. 459

48 Hours
to Ship

Lids

Lids for use with plastic and steel pails. All plastic lids are constructed of 100% prime virgin high density polyethylene (HDPE) and comply with FDA regulations. Suitable for shipping according to D.O.T. standards. Steel crimp-style lids with and without spout available for steel pails.

| MODEL NUMBER | ACCOMMODATING PAIL SIZE (GAL.) | STYLE | COLOR | WEIGHT (POUND) |
|--------------------------------|--------------------------------|----------------------------------|---------|----------------|
| PLASTIC LIDS | | | | |
| A LID-54-PN [Ⓢ] | 5 | STANDARD | NATURAL | 1 |
| A LID-54-PW [Ⓢ] | 3.5, 5 & 6 | STANDARD | WHITE | 1 |
| A LID-54-PB [Ⓢ] | 3.5, 5 & 6 | STANDARD | BLUE | 1 |
| A LID-54-PR [Ⓢ] | 3.5, 5 & 6 | STANDARD | RED | 1 |
| A LID-54-PY [Ⓢ] | 3.5, 5 & 6 | STANDARD | YELLOW | 1 |
| A LID-54-UBK [Ⓢ] | 3.5, 5 & 6 | STANDARD | BLACK | 1 |
| B LID-1-PWT [Ⓢ] | 1 | TEAR TAB | WHITE | 1 |
| B LID-2-PWT [Ⓢ] | 2 | TEAR TAB | WHITE | 1 |
| B LID-54-PWT [Ⓢ] | 3.5, 5 & 6 | TEAR TAB | WHITE | 1 |
| B LID-54-PRT [Ⓢ] | 3.5, 5 & 6 | TEAR TAB | RED | 1 |
| C LID-2-PWST [Ⓢ] | 2 | SPOUT TOP W/TEAR TAB | WHITE | 1 |
| C LID-54-PNST [Ⓢ] | 3.5, 5 & 6 | SPOUT TOP W/TEAR TAB | NATURAL | 1 |
| C LID-54-PWST [Ⓢ] | 3.5, 5 & 6 | SPOUT TOP W/TEAR TAB | WHITE | 1 |
| C LID-54-PRST [Ⓢ] | 3.5, 5 & 6 | SPOUT TOP W/TEAR TAB | RED | 1 |
| C LID-54-PYST [Ⓢ] | 3.5, 5 & 6 | SPOUT TOP W/TEAR TAB | YELLOW | 1 |
| A LID-UN-54-PW* [Ⓢ] | 5 | UN RATED | WHITE | 1 |
| C LID-UN-54-PWS* [Ⓢ] | 5 | UN RATED W/SPOUT | WHITE | 1 |
| LID-SCR | 3.5, 5 & 6.5 | SCREW TOP | WHITE | 2 |
| STEEL LIDS | | | | |
| E LID-STL [Ⓢ] | 5 | STANDARD | BLACK | 1 |
| F LID-STL-S [Ⓢ] | 5 | SPOUT TOP | BLACK | 1 |
| E LID-STL-UN* [Ⓢ] | 5 | UN RATED | BLACK | 2 |
| F LID-STL-S-UN* [Ⓢ] | 5 | UN RATED W/SPOUT | BLACK | 2 |
| G LID-STL-LL [Ⓢ] | 5 | LEVER LOCK | BLACK | 2 |
| G LID-STL-LL-UN* [Ⓢ] | 5 | UN RATED W/LEVER LOCK | BLACK | 2 |
| G LID-STL-LL-UNR* [Ⓢ] | 5 | UN RATED FOR LIQUID W/LEVER LOCK | BLACK | 2 |

*UN RATED



A



48 Hours
to Ship



B



C



E



F

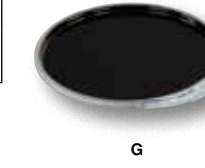

G



Pails

Strong enough for use in shipping applications and durable enough for the most demanding storage applications. Our heavy duty pails come in variety of sizes ranging from 1 to 6.5 gallons in a spectrum of colors. All plastic pails are constructed of 100% prime virgin high density polyethylene (HDPE) and comply with FDA regulations. Can be used with liquids up to 190°F, as well as in freezer applications. Steel pails with rust inhibitor lining are also available. Pails with plastic handles available in bulk, contact factory.

UN Certified when used with UN Rated covers listed on page 330:

PAIL-54: UN 1H2/Y1.5/50

PAIL-SCR-35-W: UN 1H2/Y19/S

PAIL-SCR-5-W & PAIL-SCR-65-W: UN 1H2/Y30/S

PAIL-STL-RI-UN: UN 1A2/Y1.5/70

| MODEL NUMBER | CAPACITY (GALLONS) | STYLE | HANDLE | COLOR | WEIGHT (POUND) | |
|--------------------------------|--------------------|--------------------------|-----------|---------|----------------|---|
| PLASTIC PAILS | | | | | | |
| A | PAIL-1-PWP | 1 | OPEN HEAD | PLASTIC | WHITE | 1 |
| C | PAIL-35-PWP | 3.5 | OPEN HEAD | PLASTIC | WHITE | 2 |
| D | PAIL-54-PNP-G* | 5 | OPEN-HEAD | PLASTIC | NATURAL | 3 |
| B | PAIL-2-PWS | 2 | OPEN HEAD | STEEL | WHITE | 1 |
| C | PAIL-35-PWS | 3.5 | OPEN HEAD | STEEL | WHITE | 2 |
| D | PAIL-54-PNS-G* | 5 | OPEN-HEAD | STEEL | NATURAL | 3 |
| D | PAIL-54-PWS | 5 | OPEN HEAD | STEEL | WHITE | 3 |
| E | PAIL-6-PWS | 6 | OPEN HEAD | STEEL | WHITE | 3 |
| PLASTIC PAILS WITH LIDS | | | | | | |
| F | PAIL-SCR-35-W | 3.5 | SCREW TOP | PLASTIC | WHITE | 3 |
| G | PAIL-SCR-5-W | 5 | SCREW TOP | PLASTIC | WHITE | 3 |
| G | PAIL-SCR-65-W | 6.5 | SCREW TOP | PLASTIC | WHITE | 4 |
| STEEL PAILS | | | | | | |
| H | PAIL-STL-RI | 5 | OPEN HEAD | STEEL | BLACK | 3 |
| H | PAIL-STL-RI-UN | 5 | OPEN HEAD | STEEL | BLACK | 4 |
| HANDLE | | | | | | |
| - | PAIL-HDL | REPLACEMENT STEEL HANDLE | | | | 1 |

*FEATURES GRADUATION MARKINGS & VESTIL LOGO



Jugs

For use in industrial and commercial applications. Ideal for storing or transporting a variety of liquids.

JUG: Lightweight, natural color, FDA compliant high density polyethylene (HDPE) construction. HDPE closure with EVA liner.

JUG-W: Lightweight, white color, FDA compliant high density polyethylene (HDPE) construction. HDPE closure with EVA liner.

JUG-S: Tin-plated steel construction with threaded steel closure.

| MODEL NUMBER | CAPACITY | DESCRIPTION | CAP SIZE* | CAP COLOR | WEIGHT (POUND) |
|-------------------------|------------|-------------------------|-----------|-----------|----------------|
| PLASTIC | | | | | |
| H | JUG-64 | 64 OZ. ROUND | -- | NATURAL | 1 |
| I | JUG-1-WIDE | 1 GAL. WIDE MOUTH ROUND | -- | NATURAL | 1 |
| J | JUG-W-16 | 16 OZ. RECTANGULAR | -- | NATURAL | 1 |
| J | JUG-W-32 | 32 OZ. RECTANGULAR | -- | NATURAL | 1 |
| J | JUG-W-64 | 64 OZ. RECTANGULAR | -- | NATURAL | 1 |
| J | JUG-W-1 | 1 GAL. RECTANGULAR | -- | NATURAL | 1 |
| TIN-PLATED STEEL | | | | | |
| K | JUG-S-32 | 32 OZ. RECTANGULAR | -- | METALLIC | 1 |
| K | JUG-S-64 | 64 OZ. RECTANGULAR | -- | METALLIC | 2 |
| K | JUG-S-1 | 1 GAL. RECTANGULAR | -- | METALLIC | 2 |

48 Hours to Ship

Carboys

General-purpose carboys with rugged design for use in industrial and commercial applications. Used for transporting material, not for long term storage. All carboys are constructed of natural colored FDA compliant high-density polyethylene. Models with "S" suffix come standard with 3/4" polyethylene spigot. NOT designed for use with gasoline, diesel, or kerosene.

CARB-LP: Low profile "briefcase" design for optimum ease for handling. Fits easily into confined spaces, while providing easy transport. Includes 3/4" polyethylene spigot.

CARB-T: Designed for storage and easy dispensing of water. Tilt top design includes pour spout cap, vent, and recessed bottom hand grip for easy pouring. Rectangular shape for efficient use of space. Molded in graduations listed in gallons and liters.

CARB-SSH: Rectangular wide-mouth carboys are designed for easier filling and cleaning. Stainless steel handle is standard for easy, ergonomic transport. Molded in graduations listed in gallons and liters.

| MODEL NUMBER | CAPACITY (GALLON) | DESCRIPTION | COLOR | WEIGHT (POUND) | |
|-------------------------------|---------------------------|-------------|--------------------|----------------|---|
| HANDLE | | | | | |
| A | CARB-4-LP [Ⓢ] | 4 | LOW PROFILE | NATURAL | 4 |
| TILT TOP WITH HANDLE | | | | | |
| B | CARB-T-125 [Ⓢ] | 1.25 | MOLDED HANDLE | NATURAL | 2 |
| C | CARB-T-5 [Ⓢ] | 5 | MOLDED HANDLE | NATURAL | 3 |
| STAINLESS STEEL HANDLE | | | | | |
| - | CARB-2-SSH [Ⓢ] | 2 | SS HANDLE | NATURAL | 3 |
| D | CARB-5-SSH [Ⓢ] | 5 | SS HANDLE | NATURAL | 5 |
| E | CARB-5-SSH-S [Ⓢ] | 5 | SS HANDLE & SPIGOT | NATURAL | 5 |
| ROUND WITH SPIGOT | | | | | |
| F | CARB-R-1-S [Ⓢ] | 1 | ROUND | NATURAL | 2 |
| F | CARB-R-2-S [Ⓢ] | 2 | ROUND | NATURAL | 3 |

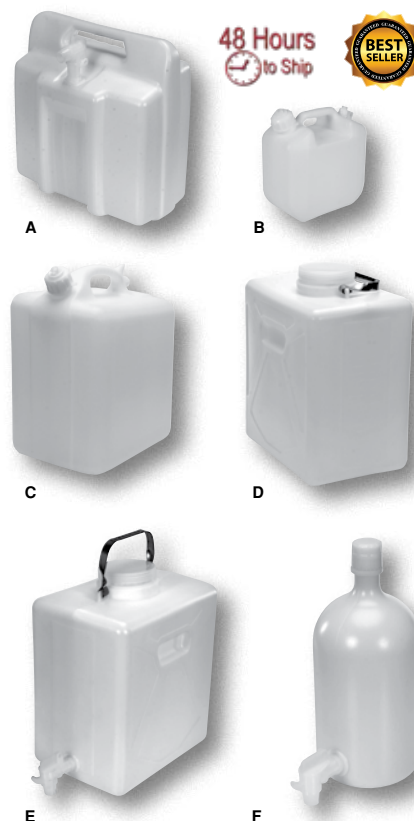

Metal Bottles

General-purpose Metal Bottles for use in applications where glass and plastic are too fragile.

BTL-MA: Aluminum bottles are lightweight and rigid. Includes polypropylene (PP) threaded cap with polyethylene (PE) foam liner.

BTL-MT: Tin-plated steel construction is ideal for storing, transporting, or packaging liquids. Includes threaded screw-on cap with polyethylene (PE) liner.

| MODEL NUMBER | CAPACITY (OUNCES) | DESCRIPTION | CAP COLOR | WEIGHT (POUND) |
|------------------------|-------------------|-------------|-----------|----------------|
| BTL-MA-2 [Ⓢ] | 2 | ALUMINUM | WHITE | >1 |
| BTL-MA-4 [Ⓢ] | 4 | ALUMINUM | WHITE | >1 |
| BTL-MA-8 [Ⓢ] | 8 | ALUMINUM | WHITE | >1 |
| BTL-MT-16 [Ⓢ] | 16 | TIN | METALLIC | >1 |
| BTL-MT-32 [Ⓢ] | 32 | TIN | METALLIC | >1 |



Tin Bottles with Brush Lids

Metal bottles are perfect for use in applications where glass and plastic are too fragile.

Tin-plated steel construction is perfect for transportation and storage of paints and lacquers. Includes brush-cap for dispensing contents. Caps are constructed of tin with a polyethylene (PE) liner.

| MODEL NUMBER | CAPACITY (OUNCES) | DESCRIPTION | CAP COVER | WEIGHT (POUND) |
|-------------------------|-------------------|-------------|-----------|----------------|
| BTL-MTB-16 [Ⓢ] | 16 | TIN | METALLIC | >1 |
| BTL-MTB-32 [Ⓢ] | 32 | TIN | METALLIC | >1 |



Round Metal Cans with Lids

Round tin-plated steel cans are perfect for use with paints and lacquers. Each can includes a press-fit lid.

| MODEL NUMBER | CAPACITY (OUNCES) | DESCRIPTION | CAP COLOR | WEIGHT (POUND) |
|---------------------|-------------------|-------------|-----------|----------------|
| MRC-4 [Ⓢ] | 4 | TIN | METALLIC | >1 |
| MRC-8 [Ⓢ] | 8 | TIN | METALLIC | >1 |
| MRC-16 [Ⓢ] | 16 | TIN | METALLIC | >1 |



Make sure you get the perfect Hydraulic Drum Crusher for your application!

Complete and return this form to the factory or your distributor.
A professional will evaluate your needs and provide you with more information.

**HDC
HYDRAULIC DRUM
CRUSHER/COMPACTOR
SURVEY SHEET**

CUSTOMER INFORMATION

CONTACT: _____
 COMPANY: _____
 PHONE: _____
 EMAIL: _____

CONTAINER SIZE

_____ 55 GALLON DRUM
 _____ 30 GALLON DRUM
 _____ OTHER
 IF NOT STANDARD DRUM SIZE PLEASE DESCRIBE: _____

DRUM MATERIAL: _____
 *STRAIGHT SIDED DRUMS CANNOT BE CRUSHED

PAINT COLOR

_____ STANDARD ERGO BLUE
 _____ RAL#
 _____ SPECIAL COLOR
 _____ COLOR NAME

POWER (CHECK ONE)

A/C
 _____ 220V, 1-PHASE, AMP HOUR REQ. 30
 _____ 208-230V, 3-PHASE, AMP HOUR REQ. 20
 _____ 460V, 3-PHASE, AMP HOUR REQ. 10
 _____ OTHER

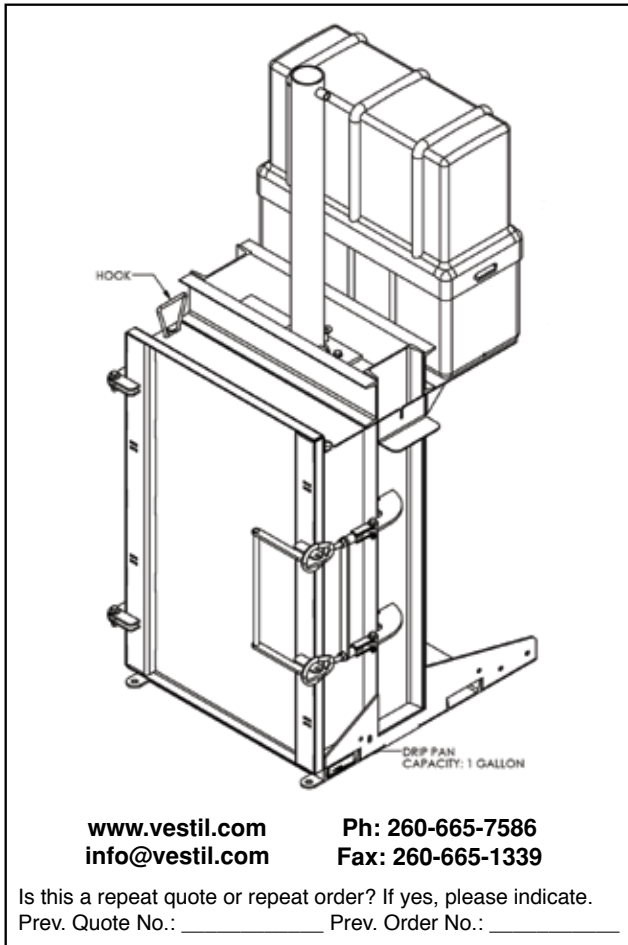

www.vestil.com Ph: 260-665-7586
info@vestil.com Fax: 260-665-1339

Is this a repeat quote or repeat order? If yes, please indicate.
 Prev. Quote No.: _____ Prev. Order No.: _____

OPTIONS (*ALL OPTIONS MAY NO BE AVAILABLE ON ALL MODELS.)

_____ HIGH CYCLE, HDC-905-HC
 _____ WASH DOWN, HDC-905-WD
 _____ GAS POWERED/PORTABLE, HDC-900-GPT
 ADDITIONAL OPTIONS: _____

APPLICATION INFORMATION

DUTY CYCLE: STARTS PER HOUR: _____ HOURS PER SHIFT: _____
 SHIFTS PER DAY: _____ DAYS PER WEEK: _____

DUTY CYCLE IS CALCULATED BY STARTS PER HOUR OR NUMBER OF TIMES "UP" BUTTON IS PUSHED.

SPECIAL TEMPERATURE REQUIREMENTS: _____

ARE THERE OVERHEAD HEIGHT RESTRICTIONS? _____

OTHER SPECIAL REQUESTS OR APPLICATION INFORMATION: _____

*NO DRUM CRUSHERS FOR CLASSIFIED LOCATIONS

Complete and return this form to the factory or your distributor. A professional will evaluate your needs and provide you with more information.

DRK-SRS-2 DRUM STORAGE RACK SURVEY SHEET

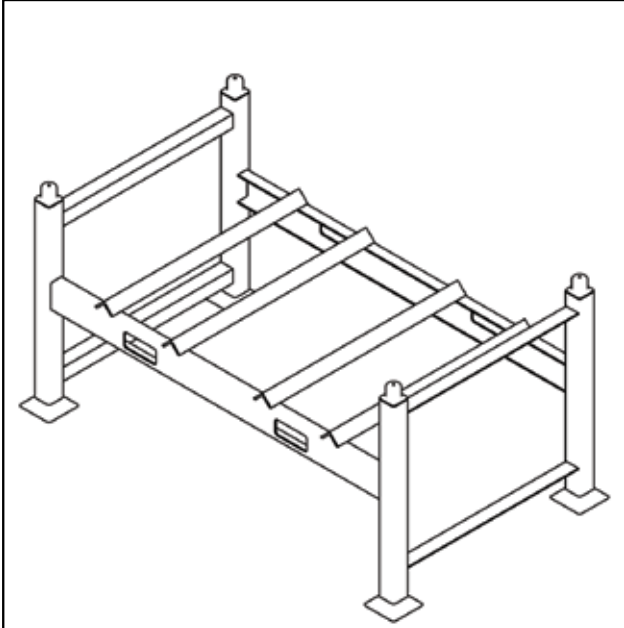

www.vestil.com
info@vestil.com

**VESTIL
MANUFACTURING**
P.O. BOX 507
ANGOLA, IN 46703

Ph: 260-665-7586
Fax: 260-665-1339

Is this a repeat quote or repeat order? If yes, please indicate.
Prev. Quote No.: _____ Prev. Order No.: _____

CUSTOMER INFORMATION

CONTACT: _____
COMPANY: _____
PHONE: _____
EMAIL: _____

PRODUCT INFO

DRUM SIZE:
DIAMETER: _____
HEIGHT: _____
CAPACITY/DRUM WEIGHT: _____

ADDITIONAL INFORMATION:

RACK SIZE

OVERALL WIDTH: _____
OVERALL DEPTH: _____
OVERALL HEIGHT: _____
USABLE DEPTH: _____
OF DRUMS TO BE STORED _____

NOT CRITICAL

APPLICATION / LOADING INFO

VESTIL MANUFACTURING COMPANY

info@vestil.com - general company inquiries and price quotes

status@vestil.com - check order status

freight@vestil.com - freight quotes

orders@vestil.com - remit purchase orders

parts@vestil.com - replacement parts

tech@vestil.com - technical product support & troubleshooting