

CASTERS & WHEELS



SUPERIOR QUALITY



PREMIUM QUALITY



ECONOMICAL





SPECIALTY CASTERS



WHEELS



CASTER ACCESSORIES

Buyer's Guide to Casters and Wheels.....	424
Selecting the Right Material.....	425
SUPERIOR QUALITY CASTERS 	
Light Duty	426-428
Medium Duty	429-430
Medium-Heavy Duty	431
PREMIUM QUALITY CASTERS 	
Medium-Heavy Duty	432
USA MADE CASTERS 	
Medium-Heavy Duty	433
SPECIALTY CASTERS	
100% Maintenance-Free	434
Spring Loaded & Towing, Extra Heavy Duty.....	435
Stainless Steel.....	436
CUSTOM-MADE CASTERS & WHEELS	437
ECONOMICAL CASTERS	
Light Duty	438-439
Medium Duty	440-441
Medium-Heavy Duty	442-443
WHEELS	444
CASTER ACCESSORIES	445-446

BUYER'S GUIDE TO CASTERS & WHEELS

All Casters Are Not Equal . . .

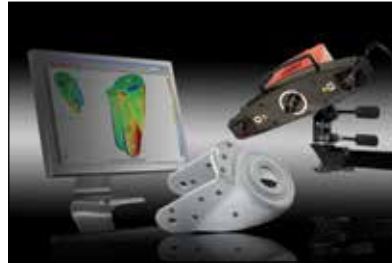
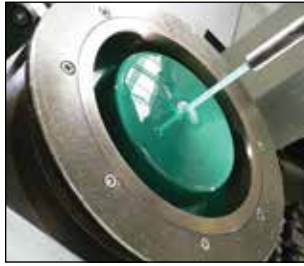

FEATURES & DESIGN

We offer a line of superior industrial casters that are *second to none*. Providing you with the safest, most reliable casters in the industry stems from having the highest quality in raw materials, design, and testing analysis. Our superior casters are rated by the following criteria and valued by the number of ★'s found next to their description. Rating criteria is below.

SUPERIOR CONSTRUCTION GUIDE

- ★★★★★ (5) = Superior Construction (includes 80% or more of the structural features below)
- ★★★★ (4) = Excellent Construction (includes 60% or more of the structural features below)
- ★★★ (3) = Exceptional Construction (includes 50% or more of the structural features below)
- ★★ (2) = Admirable Construction (includes 30% or more of the structural features below)
- ★ (1) = Good Construction (includes 25% or more of the structural features below)

SUPERIOR STRUCTURAL FEATURES INCLUDE

- Strategic Poly Bond: Sand blast and thermal cleaning of steel using a computer-controlled laser, automated adhesive applicator to ensure the same consistency every time, pre-heat mold and center (with more heat on the center to ensure poly bonds to the center first), and/or mechanically bonded together.
- Testing Analysis: May include raw material analysis, abrasion resistance, tread hardness, rotation, swivel of head, temperature resistance, rolling resistance, destructive tests, and/or locking systems (when applicable).
- State of the Art Injection Molding Machines: Equipped with linear robots or multi-lifts.
- Machined or Double Precision Steel Raceways: Offer some of the tightest performance in the industry.
- Bearing Dust Cover Seals or Thread Guards: Assist in protecting the bearings around the raceway (Dust Cover Seals) or the caster bearings (Thread Guard) from dust and debris that could impact the functionality and life of the bearings.
- High Quality Tread: Often provide longer lasting durability and better ergonomic performance than a standard tread of similar material.
- Kingpinless Design: A kingpin in a standard caster absorbs most of the abuse and tension received in a rigorous application. Over time, this can cause the kingpin to fail. Kingpinless casters provide a more even distribution of load offering stronger durability, especially in towing, heavy load, and shock absorbing applications.
- Non-Marking: Tread protects flooring from marks and scuffing.
- Anti-Corrosive Finish: Assists in protecting rigging from corrosion and rust that can inhibit the life of a caster.
- 100% of our Blickle® Casters go through a Debonding Press Test.
- 2-3 Year Warranty.
- Featured Cores:
 - A) Cast Iron or Steel: Provide better durability in high capacity applications.
 - B) Cast Aluminum: Lighter weight and offer maximum heat dissipation in high cycle applications.
 - C) Nylon or Polyolefin: Provide ideal vibration absorption. Especially useful in light capacity, low cycle applications.

SELECTING THE RIGHT MATERIAL

*Each material offers unique qualities for specific applications**

<p>Besthane®: Floor-preserving, non-marking, non-staining, highly abrasion resistant, and resistant to many aggressive substances. It is also water resistant, but not resistant to hot water, hot water vapor, humid air and aromatic solvents. Color brown. Maintenance-Free under standard conditions.</p>	<p>Besthane Soft®: High-quality-elastomer with a dynamic load capacity, non-marking, and non-staining. Also has a very low rolling resistance, good floor preservation, and high abrasion resistance. Color blue. Maintenance-Free under standard conditions.</p>
<p>Cast Iron: Wear-resistant and withstands abrasion. A relatively high floor pressure should be considered for pressure-sensitive floors. Hard tread rolls easily.</p>	<p>Extrathane®: A reaction-injected polyurethane-elastomer. It is floor-preserving, non-marking, non-staining, abrasion-resistant, and resistant to many chemicals. Non-resistant to hot water, hot water vapor, humid air, and aromatic solvents. Color light brown (butterscotch).</p>
<p>Glass Filled Nylon: Strong thermoplastic compound that resists hard impacts. Resistant to most chemicals, salts, solvents, and steam. Does not absorb water and ideal for many industrial and institutional applications. The wheel is non-marking.</p>	<p>Nylon: Impact-resistant nylon has very low rolling and swivel resistance. Provides a smooth roll on even floors and offers paramount chemical resistance to many aggressive substances.</p>
<p>Phenolic: Provides longer wear and handles high load capacities. Good for use in deep freeze temperatures. Hard tread rolls easily. Provides better floor protection and is quieter than steel wheels.</p>	<p>Polyolefin: Lightweight, resists most chemicals and oils, while providing exceptional impact resistance.</p>
<p>Polypropylene: A thermoplastic synthetic material. It is impact-resistant, non-marking, non-staining, corrosion resistant, and odorless. It also offers a low rolling resistance and does not absorb humidity. Color natural white.</p>	<p>Polyurethane: Offers paramount resistance to most oils, chemicals, solvents, and acids.</p>
<p>Rubber: Quiet-rolling, good for corrosive and damp environments. Provides shock absorption and rolls easily over small debris. Offers good floor protection and works well both in and outdoors.</p>	<p>Softthane®: High operational comfort due to an extremely thick elastic tread. Low-noise operation and rolling resistance. It is non-marking, while offering high abrasion and chemical resistance. Color green.</p>
<p>Surelastic Rubber: Characterized by a special rubber compound. This tread provides incredible floor-preserving qualities. It also offers a high load capacity, high operational comfort, and is resistant to many aggressive substances except oils. Color black.</p>	<p>Thermoplastic Polyurethane Rubber (TPR): Characterized by a non-marking, non-staining, good floor preservation. Also has low noise operation, rolling and swivel resistance. Resistant to chemicals, acids, bases, alcohol, salts, and steam. Color gray. Maintenance-free under standard conditions.</p>
<p>Thermoplastic Rubber-Elastomer (TPE): This tread provides a high operational comfort, low-noise operation, and good floor preservation. It is also non-marking. Color gray.</p>	<p>*ALL BENEFITS AND EXPECTATIONS STATED IN CATALOG ARE BASED UNDER STANDARD CONDITIONS.</p> <p>PLEASE CONTACT FACTORY FOR ADDITIONAL CASTER SIZES, MATERIALS AND TYPES.</p>

SUPERIOR QUALITY CASTERS

Made in GERMANY

New



CST-AL-5X2NY-SWTB



model CST-AL-5X2NY-S

High Quality Nylon ★★★★★

Made of **impact-resistant nylon**. Smooth running performance on even floors. Gray tread color. 70 Shore D. Wheel core material is nylon. Made in Germany.

- Impact Resistant
- Exceptionally Low Rolling Resistance
- Bearing Dust Cover Seals
- High Abrasion Resistance
- High Chemical Resistance
- Non-Staining / Non-Marking

4 YEAR WARRANTY

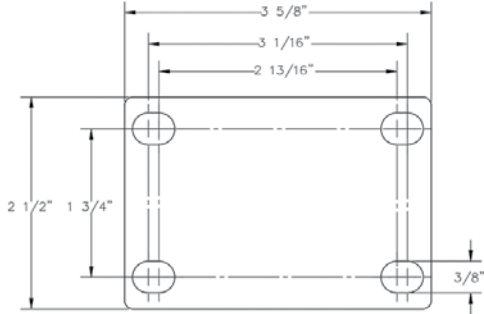

MODEL NUMBER	CASTER SIZE	CAPACITY	OVERALL HEIGHT	CASTER WHEEL BEARING	CASTER RACEWAY	WEIGHT (POUND)
SWIVEL CASTERS						
CST-AL-4X1NY-S	4" x 1 ⁷ / ₁₆ "	400 lb.	5 ¹ / ₈ "	Precision Ball	Double Ball	1.55
CST-AL-5X2NY-S	5" x 1 ⁹ / ₁₆ "	400 lb.	6 ¹ / ₈ "	Precision Ball	Double Ball	1.90
RIGID CASTERS						
CST-AL-4X1NY-R	4" x 1 ⁷ / ₁₆ "	400 lb.	5 ¹ / ₈ "	Precision Ball	--	1.32
CST-AL-5X2NY-R	5" x 1 ⁹ / ₁₆ "	400 lb.	6 ¹ / ₈ "	Precision Ball	--	1.65
SWIVEL CASTER WITH TOTAL BRAKE						
CST-AL-4X1NY-SWTB	4" x 1 ⁷ / ₁₆ "	400 lb.	5 ¹ / ₈ "	Precision Ball	Double Ball	1.60
CST-AL-5X2NY-SWTB	5" x 1 ⁹ / ₁₆ "	400 lb.	6 ¹ / ₈ "	Precision Ball	Double Ball	2.22

Made in GERMANY

New



CST-AL-5X2EX-SWTB



model CST-AL-5X2EX-S

High Quality Non-Marking Polyurethane-Elastomer ★★★★★

Made from **high-quality, reaction-cast polyurethane-elastomer** (Extrathane Soft®). Butterscotch tread color. 92 Shore A. Wheel core constructed of die cast aluminum. Made in Germany.

- Low Rolling Resistance
- High Chemical Resistance
- Non-Marking
- Bearing Dust Cover Seals

4 YEAR WARRANTY

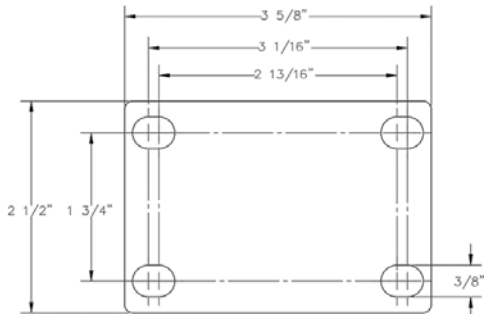

MODEL NUMBER	CASTER SIZE	CAPACITY	OVERALL HEIGHT	CASTER WHEEL BEARING	CASTER RACEWAY	WEIGHT (POUND)
SWIVEL CASTERS						
CST-AL-5X2EX-S	5" x 1 ⁹ / ₁₆ "	400 lb.	6 ¹ / ₈ "	Precision Ball	Double Ball	2.50
RIGID CASTERS						
CST-AL-5X2EX-R	5" x 1 ⁹ / ₁₆ "	400 lb.	6 ¹ / ₈ "	Precision Ball	--	2.14
SWIVEL CASTER WITH TOTAL BRAKE						
CST-AL-5X2EX-SWTB	5" x 1 ⁹ / ₁₆ "	400 lb.	6 ¹ / ₈ "	Precision Ball	Double Ball	2.85

SUPERIOR QUALITY CASTERS

Made in
GERMANY

New



CST-AL-5X2SO-SWTB



model CST-AL-5X2SO-S

High Quality Non-Marking Polyurethane-Elastomer ★★★★★

Made of **reaction-cast polyurethane-elastomer** (Softthane®). Incredible operational comfort due to an **extremely thick elastic tread**. Green tread color. 75 Shore A. Wheel core constructed of die cast aluminum. Made in Germany.

- High Chemical Resistance
- High Dynamic Load Capacity
- High Abrasion Resistance
- Low Operating Noise
- Bearing Dust Cover Seals
- Thick elastic tread for smooth operation

4 YEAR WARRANTY

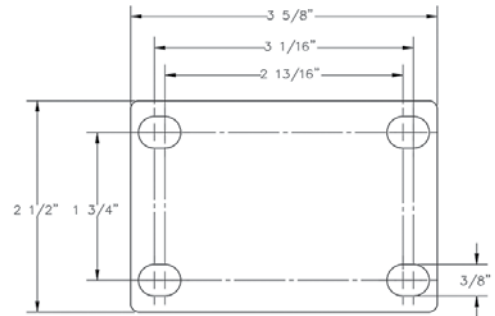

MODEL NUMBER	CASTER SIZE	CAPACITY	OVERALL HEIGHT	CASTER WHEEL BEARING	CASTER RACEWAY	WEIGHT (POUND)
SWIVEL CASTERS						
CST-AL-4X2SO-S	4" x 1 ⁹ / ₁₆ "	400 lb.	5 ¹ / ₈ "	Precision Ball	Double Ball	2.2
CST-AL-5X2SO-S	5" x 1 ⁹ / ₁₆ "	400 lb.	6 ¹ / ₈ "	Precision Ball	Double Ball	3.9
RIGID CASTERS						
CST-AL-4X2SO-R	4" x 1 ⁹ / ₁₆ "	400 lb.	5 ¹ / ₈ "	Precision Ball	--	1.9
CST-AL-5X2SO-R	5" x 1 ⁹ / ₁₆ "	400 lb.	6 ¹ / ₈ "	Precision Ball	--	2.25
SWIVEL CASTER WITH TOTAL BRAKE						
CST-AL-4X2SO-SWTB	4" x 1 ⁹ / ₁₆ "	400 lb.	5 ¹ / ₈ "	Precision Ball	Double Ball	2.5
CST-AL-5X2SO-SWTB	5" x 1 ⁹ / ₁₆ "	400 lb.	6 ¹ / ₈ "	Precision Ball	Double Ball	2.95

Made in
GERMANY

New



CST-AL-5X1TPU-SWTB



model CST-AL-5X1TPU-S

High Quality Non-Marking Thermoplastic Polyurethane ★★★★★

Made from **high-quality thermoplastic polyurethane** (TPU). Gray tread color. 94 Shore A. Wheel core is constructed of impact resistant nylon. Made in Germany.

- High Operational Comfort
- Good Floor Preservation
- Non-Staining
- Non-Marking
- Bearing Dust Cover Seals

4 YEAR WARRANTY

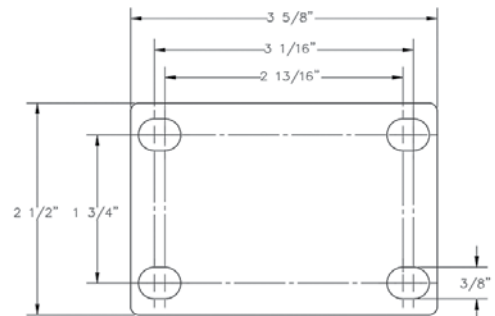

MODEL NUMBER	CASTER SIZE	CAPACITY	OVERALL HEIGHT	CASTER WHEEL BEARING	CASTER RACEWAY	WEIGHT (POUND)
SWIVEL CASTERS						
CST-AL-4X1TPU-S	4" x 1 ¹ / ₄ "	400 lb.	5 ¹ / ₈ "	Precision Ball	Double Ball	1.67
CST-AL-5X1TPU-S	5" x 1 ¹ / ₄ "	400 lb.	6 ¹ / ₈ "	Precision Ball	Double Ball	1.85
RIGID CASTERS						
CST-AL-4X1TPU-R	4" x 1 ¹ / ₄ "	400 lb.	5 ¹ / ₈ "	Precision Ball	--	1.27
CST-AL-5X1TPU-R	5" x 1 ¹ / ₄ "	400 lb.	6 ¹ / ₈ "	Precision Ball	--	1.50
SWIVEL CASTER WITH TOTAL BRAKE						
CST-AL-4X1TPU-SWTB	4" x 1 ¹ / ₄ "	400 lb.	5 ¹ / ₈ "	Precision Ball	Double Ball	1.90
CST-AL-5X1TPU-SWTB	5" x 1 ¹ / ₄ "	400 lb.	6 ¹ / ₈ "	Precision Ball	Double Ball	2.20

SUPERIOR QUALITY CASTERS

Made in GERMANY

New



model CST-AL-5X1SR-S



model CST-AL-5X1SR-SWTB

High Quality Non-Marking Solid Rubber ★★★★★

Made of elastic solid rubber for smooth rolling quality. **Vulcanized onto wheel center.** Blue tread color. 65 Shore A. Wheel core constructed of impact resistant nylon. Made in Germany.

- Non-Marking
- Low Rolling Resistance
- High Operational Comfort
- Bearing Dust Cover Seals

4 YEAR WARRANTY

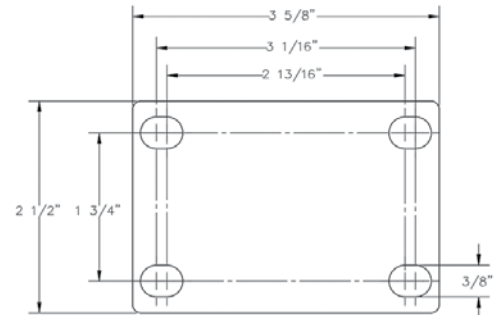

MODEL NUMBER	CASTER SIZE	CAPACITY	OVERALL HEIGHT	CASTER WHEEL BEARING	CASTER RACEWAY	WEIGHT (POUND)
SWIVEL CASTERS						
CST-AL-4X1SR-S	4" x 1 ³ / ₈ "	400 lb.	5 ¹ / ₈ "	Precision Ball	Double Ball	1.70
CST-AL-5X1SR-S	5" x 1 ³ / ₈ "	400 lb.	6 ¹ / ₈ "	Precision Ball	Double Ball	1.94
RIGID CASTERS						
CST-AL-4X1SR-R	4" x 1 ³ / ₈ "	400 lb.	5 ¹ / ₈ "	Precision Ball	--	1.35
CST-AL-5X1SR-R	5" x 1 ³ / ₈ "	400 lb.	6 ¹ / ₈ "	Precision Ball	--	1.60
SWIVEL CASTER WITH TOTAL BRAKE						
CST-AL-4X1SR-SWTB	4" x 1 ³ / ₈ "	400 lb.	5 ¹ / ₈ "	Precision Ball	Double Ball	1.86
CST-AL-5X1SR-SWTB	5" x 1 ³ / ₈ "	400 lb.	6 ¹ / ₈ "	Precision Ball	Double Ball	2.30

Made in GERMANY

New



model CST-ALK-4X1.5SR-S



model CST-ALK-4X1.5SR-SWTB

High Quality Non-Marking Solid Rubber ★★★★★

Made of elastic solid rubber for smooth rolling quality. **Vulcanized onto wheel center.** Gray tread color. 65 Shore A. Wheel core is constructed of impact resistant nylon. Made in Germany.

- Non-Marking
- Low Rolling Resistance
- High Operational Comfort
- Bearing Dust Cover Seals

4 YEAR WARRANTY

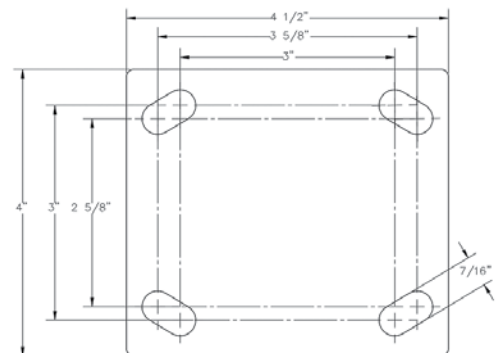

MODEL NUMBER	CASTER SIZE	CAPACITY	OVERALL HEIGHT	CASTER WHEEL BEARING	CASTER RACEWAY	WEIGHT (POUND)
SWIVEL CASTERS						
CST-ALK-4X1.5SR-S	4" x 1 ¹ / ₂ "	440 lb.	5 ¹ / ₈ "	Precision Ball	Double Ball	2.50
RIGID CASTERS						
CST-ALK-4X1.5SR-R	4" x 1 ¹ / ₂ "	440 lb.	5 ¹ / ₈ "	Precision Ball	--	2.95
SWIVEL CASTER WITH TOTAL BRAKE						
CST-ALK-4X1.5SR-SWTB	4" x 1 ¹ / ₂ "	440 lb.	5 ¹ / ₈ "	Precision Ball	Double Ball	2.97

SUPERIOR QUALITY CASTERS

Made in
GERMANY

New



model CST-ALEH-6X2NY-S



model
CST-ALEH-6X2NY-SWTB

High Quality Nylon ★★★★★

Made of **impact-resistant nylon**. **Smooth running performance** on even floors. Gray tread color. 70 Shore D. Wheel core material is nylon. Made in Germany.

- Low Rolling Resistance
- Bearing Dust Cover Seals
- High Abrasion Resistance
- Impact Resistant
- High Chemical Resistance

4 YEAR
WARRANTY

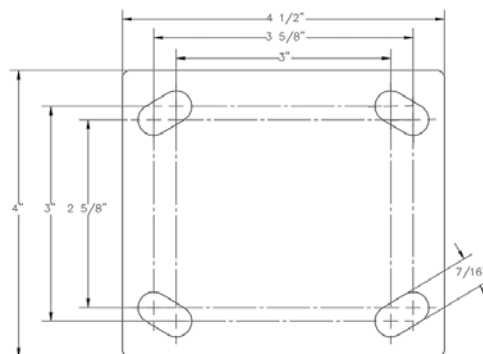

MODEL NUMBER	CASTER SIZE	CAPACITY	OVERALL HEIGHT	CASTER WHEEL BEARING	CASTER RACEWAY	WEIGHT (POUND)
SWIVEL CASTERS						
CST-ALEH-6X2NY-S	6" x 2"	1,250 lb.	7½"	Precision Ball	Double Ball	4.85
CST-ALEH-8X2NY-S	8" x 2"	1,250 lb.	9½"	Precision Ball	Double Ball	7
RIGID CASTERS						
CST-ALEH-6X2NY-R	6" x 2"	1,250 lb.	7½"	Precision Ball	--	4.5
CST-ALEH-8X2NY-R	8" x 2"	1,250 lb.	9½"	Precision Ball	--	6.5
SWIVEL CASTER WITH TOTAL BRAKE						
CST-ALEH-6X2NY-SWTB	6" x 2"	1,250 lb.	7½"	Precision Ball	Double Ball	5.5
CST-ALEH-8X2NY-SWTB	8" x 2"	1,250 lb.	9½"	Precision Ball	Double Ball	7.13

Made in
GERMANY

New



model CST-ALEH-8X2EX-S



model
CST-ALEH-8X2EX-SWTB

48 Hours
to Ship

4 YEAR
WARRANTY

High Quality Non-Marking Polyurethane-Elastomer ★★★★★

Made from **high-quality, reaction-cast polyurethane-elastomer** (Extrathane®). Model CST-ALH-6X2EX-S, -R, -SWTB feature a 4½" x 6¼" top plate. Drawing below represents other models. Butterscotch tread color. 92 Shore A. Wheel core is constructed of die cast aluminum. Made in Germany.

- Non-Staining
- Bearing Dust Cover Seals
- Non-Marking
- High Chemical Resistance

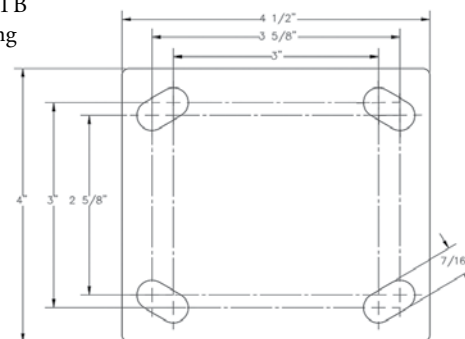

MODEL NUMBER	CASTER SIZE	CAPACITY	OVERALL HEIGHT	CASTER WHEEL BEARING	CASTER RACEWAY	WEIGHT (POUND)
SWIVEL CASTERS						
CST-ALH-5X2EX-S	5" x 1 ⁹ / ₁₆ "	770 lb.	6½"	Precision Ball	Double Ball	4.75
CST-ALH-6X2EX-S	6" x 2"	1,100 lb.	7 ³ / ₄ "	Precision Ball	Double Ball	7.89
CST-ALEH-6X2EX-S	6" x 2"	1,100 lb.	7½"	Precision Ball	Double Ball	5.04
CST-ALEH-8X2EX-S	8" x 2"	1,250 lb.	9½"	Precision Ball	Double Ball	6.26
RIGID CASTERS						
CST-ALH-5X2EX-R	5" x 1 ⁹ / ₁₆ "	770 lb.	6½"	Precision Ball	--	4.40
CST-ALH-6X2EX-R	6" x 2"	1,100 lb.	7 ³ / ₄ "	Precision Ball	--	5.85
CST-ALEH-6X2EX-R	6" x 2"	1,100 lb.	7½"	Precision Ball	-	4.18
CST-ALEH-8X2EX-R	8" x 2"	1,250 lb.	9½"	Precision Ball	--	6.40
SWIVEL CASTER WITH TOTAL BRAKE						
CST-ALH-5X2EX-SWTB	5" x 1 ⁹ / ₁₆ "	770 lb.	6½"	Precision Ball	Double Ball	5.50
CST-ALH-6X2EX-SWTB	6" x 2"	1,100 lb.	7 ³ / ₄ "	Precision Ball	Double Ball	8.50
CST-ALEH-6X2EX-SWTB	6" x 2"	1,100 lb.	7½"	Precision Ball	Double Ball	6.17
CST-ALEH-8X2EX-SWTB	8" x 2"	1,250 lb.	9½"	Precision Ball	Double Ball	7.53

SUPERIOR QUALITY CASTERS

Made in GERMANY



New

model CST-ALK-5X2SR-SWTB

**High Quality Non-Marking ★★★★★
Solid Rubber**

Made of elastic solid rubber for smooth rolling. **Vulcanized onto wheel center.** Gray tread color. 65 Shore A. Wheel core is constructed of **impact resistant nylon.** Made in Germany.

- Bearing Dust Cover Seals
- Low Rolling Resistance
- Non-Marking
- High Operational Comfort

4 YEAR WARRANTY

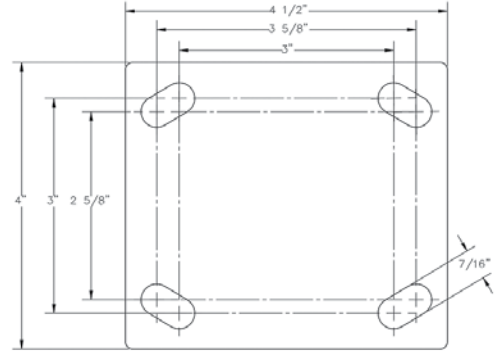

model CST-ALK-5X2SR-S

MODEL NUMBER	CASTER SIZE	CAPACITY	OVERALL HEIGHT	CASTER WHEEL BEARING	CASTER RACEWAY	WEIGHT (POUND)
SWIVEL CASTERS						
CST-ALK-5X2SR-S	5" x 1 ⁹ / ₁₆ "	550 lb.	6 ¹ / ₈ "	Precision Ball	Double Ball	2.80
RIGID CASTERS						
CST-ALK-5X2SR-R	5" x 1 ⁹ / ₁₆ "	550 lb.	6 ¹ / ₈ "	Precision Ball	--	2.50
SWIVEL CASTER WITH TOTAL BRAKE						
CST-ALK-5X2SR-SWTB	5" x 1 ⁹ / ₁₆ "	550 lb.	6 ¹ / ₈ "	Precision Ball	Double Ball	3.10

Made in GERMANY



New

model CST-ALEH-6X2TPU-SWTB

**High Quality Non-Marking ★★★★★
Thermoplastic Polyurethane**

Made from **high-quality thermoplastic polyurethane (TPU).** Gray tread color. 94 Shore A. Wheel core is constructed of **impact resistant nylon.** Made in Germany.

- Bearing Dust Cover Seals
- Non-Marking
- High Operational Comfort
- Good Floor Preservation
- Non-Staining

4 YEAR WARRANTY

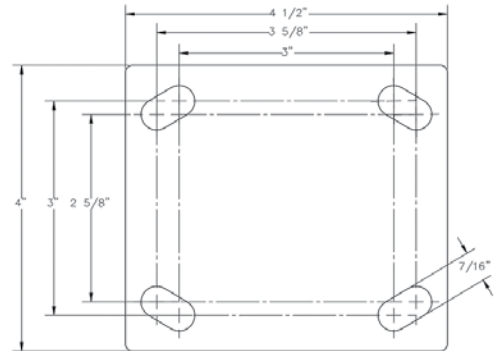

model CST-ALEH-6X2TPU-S

48 Hours to Ship

MODEL NUMBER	CASTER SIZE	CAPACITY	OVERALL HEIGHT	CASTER WHEEL BEARING	CASTER RACEWAY	WEIGHT (POUND)
SWIVEL CASTERS						
CST-ALEH-6X2TPU-S	6" x 1 ³ / ₄ "	1,100 lb.	7 ¹ / ₂ "	Precision Ball	Double Ball	4.53
CST-ALEH-8X2TPU-S	8" x 2"	1,250 lb.	9 ¹ / ₂ "	Precision Ball	Double Ball	5.8
RIGID CASTERS						
CST-ALEH-6X2TPU-R	6" x 1 ³ / ₄ "	1,100 lb.	7 ¹ / ₂ "	Precision Ball	--	4.70
CST-ALEH-8X2TPU-R	8" x 2"	1,250 lb.	9 ¹ / ₂ "	Precision Ball	--	6.06
SWIVEL CASTER WITH TOTAL BRAKE						
CST-ALEH-6X2TPU-SWTB	6" x 1 ³ / ₄ "	1,100 lb.	7 ¹ / ₂ "	Precision Ball	Double Ball	5.73
CST-ALEH-8X2TPU-SWTB	8" x 2"	1,250 lb.	9 ¹ / ₂ "	Precision Ball	Double Ball	7.11

SUPERIOR QUALITY CASTERS

Made in GERMANY

New



High Quality Non-Marking Polyurethane-Elastomer ★★★★★

Made of reaction-cast polyurethane-elastomer (Besthane Soft®). Provides paramount operational comfort due to a thick elastic tread. High dynamic load capacity. Blue tread color. 75 Shore A. Wheel core is constructed of die cast aluminum. Made in Germany.

- Non-Marking
- Non-Staining
- Low Rolling Resistance
- Low Operating Noise
- Bearing Dust Cover Seals

4 YEAR WARRANTY

48 Hours to Ship

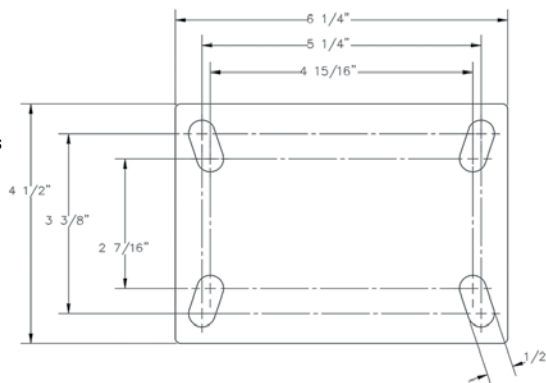

model CST-ALH-6X2BESO-SWTB

model CST-ALH-8X2BESO-SWTB

MODEL NUMBER	CASTER SIZE	CAPACITY	OVERALL HEIGHT	CASTER WHEEL BEARING	CASTER RACEWAY	WEIGHT (POUND)
SWIVEL CASTERS						
CST-ALH-6X2BESO-S	6" x 2"	1,100 lb.	7 ³ / ₄ "	Precision Ball	Double Ball	8.30
CST-ALH-8X2BESO-S	8" x 2"	1,540 lb.	9 ⁵ / ₈ "	Precision Ball	Double Ball	9.45
RIGID CASTERS						
CST-ALH-6X2BESO-R	6" x 2"	1,100 lb.	7 ³ / ₄ "	Precision Ball	--	6.30
CST-ALH-8X2BESO-R	8" x 2"	1,540 lb.	9 ⁵ / ₈ "	Precision Ball	--	7.40
SWIVEL CASTER WITH TOTAL BRAKE						
CST-ALH-6X2BESO-SWTB	6" x 2"	1,100 lb.	7 ³ / ₄ "	Precision Ball	Double Ball	9.67
CST-ALH-8X2BESO-SWTB	8" x 2"	1,540 lb.	9 ⁵ / ₈ "	Precision Ball	Double Ball	11.0

Made in GERMANY

New



Polyurethane-Elastomer ★★★★★

Made of reaction-cast polyurethane-elastomer (Softhane®). Operational comfort due to an extremely thick, elastic tread. Green tread color. 75 Shore A. Wheel core is constructed of die cast aluminum. Made in Germany.

- Bearing Dust Cover Seals
- Non-Marking
- High Dynamic Load Capacity
- High Chemical Resistance
- High Abrasion Resistance

4 YEAR WARRANTY

48 Hours to Ship

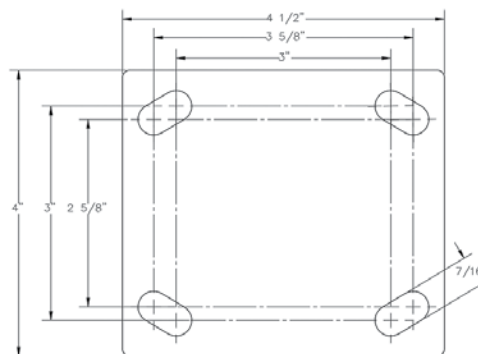

model CST-ALEH-6X2SO-SWTB

model CST-ALEH-6X2SO-S

MODEL NUMBER	CASTER SIZE	CAPACITY	OVERALL HEIGHT	CASTER WHEEL BEARING	CASTER RACEWAY	WEIGHT (POUND)
SWIVEL CASTERS						
CST-ALEH-6X2SO-S	6" x 2 ¹ / ₈ "	1,100 lb.	7 ¹ / ₂ "	Precision Ball	Double Ball	5.55
CST-ALEH-8X2SO-S	8" x 2"	1,250 lb.	9 ¹ / ₂ "	Precision Ball	Double Ball	6.6
RIGID CASTERS						
CST-ALEH-6X2SO-R	6" x 2 ¹ / ₈ "	1,100 lb.	7 ¹ / ₂ "	Precision Ball	--	5.65
CST-ALEH-8X2SO-R	8" x 2"	1,250 lb.	9 ¹ / ₂ "	Precision Ball	--	6.86
SWIVEL CASTER WITH TOTAL BRAKE						
CST-ALEH-6X2SO-SWTB	6" x 2 ¹ / ₈ "	1,100 lb.	7 ¹ / ₂ "	Precision Ball	Double Ball	6.65
CST-ALEH-8X2SO-SWTB	8" x 2"	1,250 lb.	9 ¹ / ₂ "	Precision Ball	Double Ball	8

MEDIUM-HEAVY DUTY • (1,100 to 1,540 pounds)

PREMIUM QUALITY CASTERS

Made in
TAIWAN



High-Quality Non-Marking Thermoplastic Rubber ★★★★★

Made of **high-tech thermoplastic rubber, TPR** (Duratek®) mechanically bonded to core. Gray tread color. 65 Shore A. Wheel core is constructed of polyolefin. Made in Taiwan.

- Kingpinless
- Non-Marking
- Smooth Operation
- Exceptional Floor Preservation
- Resists Most Solvents, Oil, Grease, & Water
- Higher Capacity than Standard TPR
- Great for Factory, Institution, and Food Service Environments
- Roller Bearing (available with precision ball bearings) - contact factory

3 YEAR WARRANTY



48 Hours
to Ship

model CST-F40-6X2DK-S

MODEL NUMBER	CASTER SIZE	CAPACITY	OVERALL HEIGHT	TOP PLATE SIZE	WEIGHT (POUND)
SWIVEL CASTERS (swivel rig zerk fitting & axle wheel zerk fitting)					
CST-F40-6X2DK-S	6" x 2"	600 lb.	7 1/2"	4" x 4 1/2"	5.55
RIGID CASTERS (axle wheel zerk fitting)					
CST-F40-6X2DK-R	6" x 2"	600 lb.	7 1/2"	4" x 4 1/2"	5
SWIVEL CASTER WITH BRAKE (swivel rig zerk fitting & axle wheel zerk fitting)					
CST-F40-6X2DK-SWB	6" x 2"	600 lb.	7 1/2"	4" x 4 1/2"	6.05

Made in
TAIWAN



High-Tech Non-Marking Polyurethane ★★★★★

Made of **100% pure polyurethane tread** (Duratough®). Designed with a new liquid cast flow affusion that ensures a 100% bond and "zero" trapped air. Green tread color. 90 ±5 Shore A. Wheel center is constructed of polyolefin. Made in Taiwan.

- Kingpinless
- Non-Marking
- Smooth Roll
- 100% Bond of Tread to Core
- Resists Oil, Grease, Water, and Most Solvents
- Roller Bearing (available with precision ball bearings) - contact factory

3 YEAR WARRANTY



100% BOND OF TREAD TO THE CORE



48 Hours
to Ship

model CST-F40-6X2DT-S

MODEL NUMBER	CASTER SIZE	CAPACITY	OVERALL HEIGHT	TOP PLATE SIZE	WEIGHT (POUND)
SWIVEL CASTERS (swivel rig zerk fitting & axle wheel zerk fitting)					
CST-F40-6X2DT-S	6" x 2"	900 lb.	7 1/2"	4" x 4 1/2"	5.75
CST-F40-8X2DT-S	8" x 2"	1,000 lb.	9 1/2"	4" x 4 1/2"	6.75
RIGID CASTERS (axle wheel zerk fitting)					
CST-F40-6X2DT-R	6" x 2"	900 lb.	7 1/2"	4" x 4 1/2"	5
CST-F40-8X2DT-R	8" x 2"	1,000 lb.	9 1/2"	4" x 4 1/2"	6.25
SWIVEL CASTER WITH BRAKE (swivel rig zerk fitting & axle wheel zerk fitting)					
CST-F40-6X2DT-SWB	6" x 2"	900 lb.	7 1/2"	4" x 4 1/2"	6.07
CST-F40-8X2DT-SWB	8" x 2"	1,000 lb.	9 1/2"	4" x 4 1/2"	7.25

Made in
TAIWAN



Premium Heavy Duty Polyurethane ★★★★★

Made of exclusive **premium grade proprietary polyurethane** with donut tread (Sirius Heavy Duty®). Ideal for applications where superior strength and high ergonomic performance is required. Orange tread color. 85 ±5 Shore A. Wheel core is constructed of aluminum. Made in Taiwan.

- Kingpinless
- High Capacity
- Non-Marking
- Precision Sealed Ball Bearing
- Ideal for TOWLINE Applications (3/8" diameter steel ball bearings absorb thrust and load)
- Donut Tread Allows for Easier Roll Ability
- Precision Machined and Induction Hardened Raceway

3 YEAR WARRANTY



48 Hours
to Ship

model CST-F40-6X2SI-S

MODEL NUMBER	CASTER SIZE	CAPACITY	OVERALL HEIGHT	TOP PLATE SIZE	WEIGHT (POUND)
SWIVEL CASTERS (swivel rig zerk fitting & axle wheel zerk fitting)					
CST-F40-6X2SI-S	6" x 2"	1,500 lb.	7 1/2"	4" x 4 1/2"	6.25
CST-F40-8X2SI-S	8" x 2"	2,000 lb.	9 1/2"	4" x 4 1/2"	7.75
RIGID CASTERS (axle wheel zerk fitting)					
CST-F40-6X2SI-R	6" x 2"	1,500 lb.	7 1/2"	4" x 4 1/2"	5.75
CST-F40-8X2SI-R	8" x 2"	2,000 lb.	9 1/2"	4" x 4 1/2"	7.25
SWIVEL CASTER WITH BRAKE (swivel rig zerk fitting & axle wheel zerk fitting)					
CST-F40-6X2SI-SWB	6" x 2"	1,500 lb.	7 1/2"	4" x 4 1/2"	6.63
CST-F40-8X2SI-SWB	8" x 2"	2,000 lb.	9 1/2"	4" x 4 1/2"	8.00

USA MADE CASTERS

High-Quality Polyurethane-Elastomer ★★★★★

Made of proprietary polyurethane-elastomer that allows tread to **retain its shape, reject debris**, and **increase its stored energy** to boost **ergonomic performance**. This superior caster is designed to **reduce the force exerted** to turn or start rolling, even when all wheels are not parallel. It also features **neoprene sealed precision ball bearings** and hardened raceways, providing a smooth rotation with less effort. Caramel tread color. 83+/-5 Shore A. Wheel core is constructed of aluminum. Made in the USA*.

- Kingpinless
- 100% Mechanical Bond to Core
- Reduce Push/Pull Effort Up to 50%
- Non-Marking
- Sealed Neoprene Precision Ball Bearing
- Noise Reduction
- Polyurethane Tread is Nearly 2" Thick
- Thicker, Heavier Duty Core for Long Lasting Durability
- Bearings are Off-Set for Greater Ergonomics and Load Distribution
- Crown Tread Reduces Push/Pull Effort
- Thicker Top Hat Bushings for Extended Life

3 YEAR WARRANTY

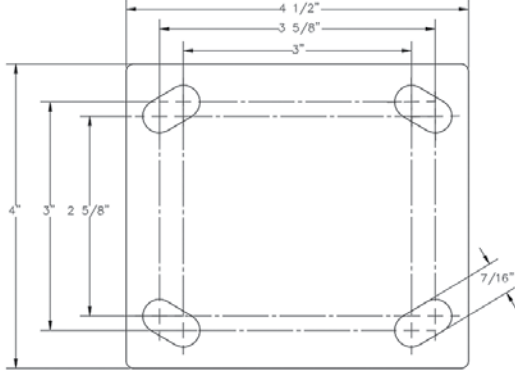

New

Made in
U.S.A.



model CST-JKING-6X2UL-S



model CST-JKING-6X2UL-SWB

48 Hours
to Ship

MODEL NUMBER	CASTER SIZE	CAPACITY	OVERALL HEIGHT	TOP PLATE SIZE	WEIGHT (POUND)
SWIVEL CASTERS (swivel rig zerk fitting)					
CST-JKING-6X2UL-S	6" x 2"	1,250 lb.	7 1/2"	4" x 4 1/2"	7.3
CST-JKING-8X2UL-S	8" x 2"	1,500 lb.	10 1/8"	4" x 4 1/2"	8.5
RIGID CASTERS					
CST-JKING-6X2UL-R	6" x 2"	1,250 lb.	7 1/2"	4" x 4 1/2"	5.55
CST-JKING-8X2UL-R	8" x 2"	1,500 lb.	10 1/8"	4" x 4 1/2"	7
SWIVEL CASTER WITH BRAKE (swivel rig zerk fitting)					
CST-JKING-6X2UL-SWB	6" x 2"	1,250 lb.	7 1/2"	4" x 4 1/2"	7.65
CST-JKING-8X2UL-SWB	8" x 2"	1,500 lb.	10 1/8"	4" x 4 1/2"	9.5

S and SWB models Swivel Rig Zerk Fitting

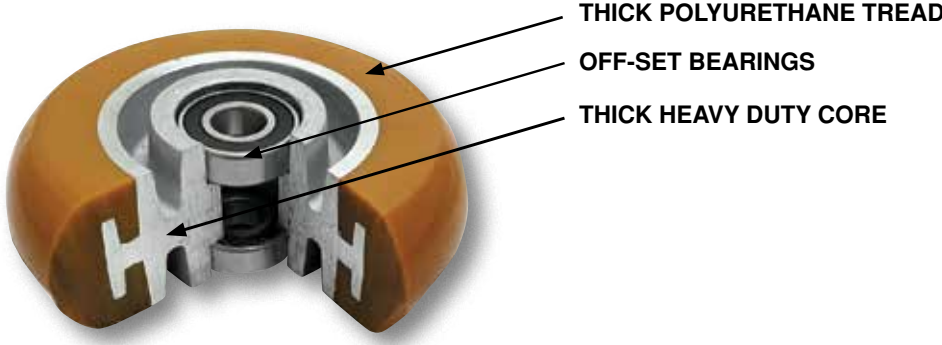

*Meets NAFTA standards for made in the USA.

MEDIUM-HEAVY DUTY • (1,250 TO 1,500 pounds)

SPECIALTY CASTERS

Made in
TAIWAN

New



3 YEAR
WARRANTY

Maintenance
Free

model
CST-FC47-6X2DK-S

48 Hours
to Ship



model
CST-FC47-6X2DK-SWB

CASTERS FEATURE . . .

- ★ Chrome Finish (swivel caster)
- ★ Double Precision Raceway for one of the tightest swivels in the industry



Thermoplastic Rubber ★★★★★

Made of high-tech thermoplastic rubber, TPR (Duratek®) mechanically bonded to core. Tread has been matched with a **double precision rigging** that offers one of the smoothest rotations in the industry. Swivel sports a high-class **three layered finish: brass, nickel, and chrome**. Rigid comes standard in zinc. Gray tread color. 65 Shore A. Wheel core is constructed of polyolefin.

- Axle Wheel Zerk Fitting • Non-Marking • Resists Most Solvents • Precision Sealed Bearing

MODEL NUMBER	CASTER SIZE	CAPACITY	OVERALL HEIGHT	TOP PLATE SIZE	WEIGHT (POUND)
SWIVEL CASTERS					
CST-FC47-6X2DK-S	6" x 2"	600 lb.	7 1/2"	4" x 4 1/2"	5.49
CST-FC47-8X2DK-S	8" x 2"	675 lb.	9 1/2"	4" x 4 1/2"	6.45
RIGID CASTERS					
CST-FC47-6X2DK-R	6" x 2"	600 lb.	7 1/2"	4" x 4 1/2"	4.85
CST-FC47-8X2DK-R	8" x 2"	675 lb.	9 1/2"	4" x 4 1/2"	5.85
SWIVEL CASTER WITH BRAKE					
CST-FC47-6X2DK-SWB	6" x 2"	600 lb.	7 1/2"	4" x 4 1/2"	6.04
CST-FC47-8X2DK-SWB	8" x 2"	675 lb.	9 1/2"	4" x 4 1/2"	6.95

Made in
TAIWAN

New



3 YEAR
WARRANTY

Maintenance
Free

model
CST-FC47-6X2DT-S

48 Hours
to Ship



model
CST-FC47-6X2DT-SWB

Polyurethane ★★★★★

Made of 100% pure polyurethane tread (Duratough®). Designed with a new liquid cast flow affusion that ensures a **100% bond and "zero" trapped air**. Tread has been matched with a **double precision rigging** that offers one of the smoothest rotations in the industry. Swivel sports a high-class **three layered finish: brass, nickel, and chrome**. Rigid comes standard in zinc. Green tread color. 90-96 Shore A. Wheel center is constructed of polyolefin.



100% BOND OF TREAD
TO THE CORE

- Axle Wheel Zerk Fitting • 100% Bond of Tread to the Core • Precision Sealed Bearing

MODEL NUMBER	CASTER SIZE	CAPACITY	OVERALL HEIGHT	TOP PLATE SIZE	WEIGHT (POUND)
SWIVEL CASTERS					
CST-FC47-6X2DT-S	6" x 2"	900 lb.	7 1/2"	4" x 4 1/2"	5.75
CST-FC47-8X2DT-S	8" x 2"	1,000 lb.	9 1/2"	4" x 4 1/2"	6.75
RIGID CASTERS					
CST-FC47-6X2DT-R	6" x 2"	900 lb.	7 1/2"	4" x 4 1/2"	5
CST-FC47-8X2DT-R	8" x 2"	1,000 lb.	9 1/2"	4" x 4 1/2"	6.25
SWIVEL CASTER WITH BRAKE					
CST-FC47-6X2DT-SWB	6" x 2"	900 lb.	7 1/2"	4" x 4 1/2"	6.25
CST-FC47-8X2DT-SWB	8" x 2"	1,000 lb.	9 1/2"	4" x 4 1/2"	7.25

Made in
TAIWAN

New



3 YEAR
WARRANTY

Maintenance
Free

model
CST-FC47-6X2SI-SWB

48 Hours
to Ship

Heavy Duty Polyurethane ★★★★★

Made of exclusive premium grade proprietary polyurethane with **donut tread** (Sirius Heavy Duty®). Ideal for applications where **superior strength and high ergonomic performance** is required. Tread has been matched with a **double precision rigging** that offers one of the smoothest rotations in the industry. Swivel sports a high-class **three layered finish: brass, nickel, and chrome**. Rigid comes standard in zinc. Orange tread color. 85 Shore A. Wheel core is constructed of aluminum.

- Axle Wheel Zerk Fitting • High Capacity • Non-Marking • Precision Sealed Bearing

MODEL NUMBER	CASTER SIZE	CAPACITY	OVERALL HEIGHT	TOP PLATE SIZE	WEIGHT (POUND)
SWIVEL CASTERS					
CST-FC47-6X2SI-S	6" x 2"	1,500 lb.	7 1/2"	4" x 4 1/2"	6.25
CST-FC47-8X2SI-S	8" x 2"	2,000 lb.	9 1/2"	4" x 4 1/2"	7.5
RIGID CASTERS					
CST-FC47-6X2SI-R	6" x 2"	1,500 lb.	7 1/2"	4" x 4 1/2"	5.63
CST-FC47-8X2SI-R	8" x 2"	2,000 lb.	9 1/2"	4" x 4 1/2"	7.1
SWIVEL CASTER WITH BRAKE					
CST-FC47-6X2SI-SWB	6" x 2"	1,500 lb.	7 1/2"	4" x 4 1/2"	6.81
CST-FC47-8X2SI-SWB	8" x 2"	2,000 lb.	9 1/2"	4" x 4 1/2"	8.1

SPECIALTY CASTERS

Japanese Engineered Spring Loaded Towing Casters (SLT) ★★ ★

These Japanese engineered casters are one of the only in the market specially designed for **spring-loading AND towing** applications. Its **high-performance polyurethane** is **abrasion resistant and tolerates longer distances, while providing great absorption.** The *state-of-the-art* caster raceway is made up of **both a radial bearing** that allows for smooth operation for towing applications, and a **thrust bearing**, which provides paramount absorption for heavy loads. The **springs provide extra support** for sensitive product. Yellow tread color. 92 ±5 Shore A. Made in China.

- Radial Bearing Supports Horizontal Force (Towing)
- Spring Loaded Supports Shock Absorption
- Thrust Bearing Supports Vertical Force (Load Impact)
- Non-Marking
- Noise Reduction
- Dust Cover Seals
- Abrasion Resistant Polyurethane



48 Hours
to Ship

model CST-G80-6X2PU-S

MODEL NUMBER	CASTER SIZE	CAPACITY	OVERALL HEIGHT	TOP PLATE SIZE	WEIGHT (POUND)
SWIVEL CASTERS					
CST-G80-6X2PU-S	6" x 1 3/4"	308 - 550 lb.	7.28" - 8.07"	4 1/2" x 6 1/4"	13.75
RIGID CASTERS					
CST-G80-6X2PU-R	6" x 1 3/4"	308 - 550 lb.	7.28" - 8.07"	4 1/2" x 6 1/4"	12

Extra Heavy Duty Kingpinless Casters ★★ ★

Ideal for **shock loading applications** that result in lost ball bearings in other constructions. **Great for towing and higher load capacities.** Top plate measures 4 1/2" x 6 1/4". Yellow tread color. Wheel core is constructed of silver iron. Made in China.

- Kingpinless
- Ideal for High Load Capacities & Towing Applications
- Precision Ball Bearing
- S and SWB models Swivel Rig Zerk Fitting
- High Operational Comfort
- Good Floor Preservation
- Axle Wheel Zerk Fitting

MODEL NUMBER	CASTER SIZE	CAPACITY	OVERALL HEIGHT	CASTER RACEWAY	WEIGHT (POUND)
SWIVEL CASTERS					
CST-APKING-6X3PU-S	6" x 3"	2,200 lb.	7 1/2"	Kingpinless	20.14
CST-APKING-8X3PU-S	8" x 3"	3,960 lb.	10 1/8"	Kingpinless	24.14
RIGID CASTERS					
CST-APKING-6X3PU-R	6" x 3"	2,200 lb.	7 1/2"	--	17.9
CST-APKING-8X3PU-R	8" x 3"	3,960 lb.	10 1/8"	--	21.10
SWIVEL CASTER WITH BRAKE					
CST-APKING-6X3PU-SWB	6" x 3"	2,200 lb.	7 1/2"	Kingpinless	21
CST-APKING-8X3PU-SWB	8" x 3"	3,960 lb.	10 1/8"	Kingpinless	25



model CST-APKING-8X3PU-S

High Capacity Non-Marking Glass Filled Nylon ★★ ★

Made of high-tech proprietary glass filled nylon (ROLLX™). Designed to be ergonomically efficient. **Resists most chemicals, solvents, gases, acids and steam cleaning. Provides a higher capacity than most glass filled nylon and phenolic casters, while weighing less.** It also **does not absorb water.** Top plate measures 4 1/2" x 6 1/4". Black tread color. 85 Shore D. Wheel core material is glass filled nylon (ROLLX™). Made in Canada.

- Kingpinless
- Environmentally Friendly
- Roller Bearing
- Higher capacity than steel or phenolic with less weight
- High impact resistance, absorbs impact without chipping or cracking
- Non-Marking



model CST-HTY-8X3GFN-S

3 YEAR
WARRANTY

MODEL NUMBER	CASTER SIZE	CAPACITY	OVERALL HEIGHT	CASTER RACEWAY	WEIGHT (POUND)
SWIVEL CASTERS (swivel rig zerk fitting & axle wheel zerk fitting)					
CST-HTY-8X3GFN-S	8" x 3"	3,500 lb.	9 1/2"	Kingpinless	15.30
RIGID CASTERS (axle wheel zerk fitting)					
CST-HTY-8X3GFN-R	8" x 3"	3,500 lb.	9 1/2"	--	11.80
FOUR POSITION SWIVEL CASTER WITH LOCK (swivel rig zerk fitting & axle wheel zerk fitting)					
CST-HTY-8X3GFN-4PSL	8" x 3"	3,500 lb.	9 1/2"	Kingpinless	15.45



model CST-HTY-8X3GFN-4PSL

SPECIALTY CASTERS

Made in GERMANY

New



model
CST-A-SS-5X1TPE-S

Stainless Steel Thermoplastic Rubber-Elastomer ★★★★★

Made of high-quality thermoplastic rubber-elastomer (TPE). Resistant to chemicals, acids, bases, alcohol, salts, and steam. Gray tread color. 85 Shore A. Wheel core is constructed of impact resistant polypropylene. Made in Germany.

- 304 Stainless Steel Rigging
- Stainless Steel Ball Bearing
- Low Rolling Resistance
- 100% Chemical Bond of Tread to Core
- Non-Marking
- Bearing Dust Cover Seals
- Good for Food Grade Applications
- High Operational Comfort

4 YEAR WARRANTY

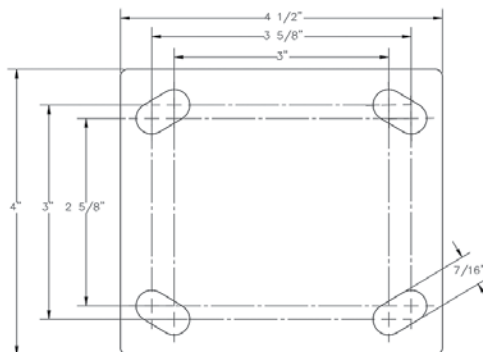

MODEL NUMBER	CASTER SIZE	CAPACITY	OVERALL HEIGHT	CASTER RACEWAY	WEIGHT (POUND)
SWIVEL CASTERS					
CST-A-SS-4X1TPE-S	4" x 1 1/4"	220 lb.	5 1/8"	Double Ball	2.25
CST-A-SS-5X1TPE-S	5" x 1 1/4"	275 lb.	6 1/8"	Double Ball	2.50
RIGID CASTERS					
CST-A-SS-4X1TPE-R	4" x 1 1/4"	220 lb.	5 1/8"	--	2.10
CST-A-SS-5X1TPE-R	5" x 1 1/4"	275 lb.	6 1/8"	--	2.20
SWIVEL CASTER WITH TOTAL BRAKE					
CST-A-SS-4X1TPE-SWTB	4" x 1 1/4"	220 lb.	5 1/8"	Double Ball	2.90
CST-A-SS-5X1TPE-SWTB	5" x 1 1/4"	275 lb.	6 1/8"	Double Ball	2.90



model
CST-BSS-6X2NY-S

New

Stainless Steel Nylon Caster ★★★★★

Excellent corrosion resistance. Ideal for applications where frequent wash downs are a necessity or have exposure to cleaning agents, steam, or other corrosive agents which could rust or corrode. Nylon wheels provide high chemical resistance as well as offer high abrasion resistance. White tread color. Wheel core is nylon. 100 Shore A. Made in China.

- 304 Stainless Steel Rigging
- High Operational Comfort
- Good Floor Preservation
- Non-Marking
- Roller Bearing
- Swivel Rig Zerk Fitting on Swivel Caster

48 Hours to Ship

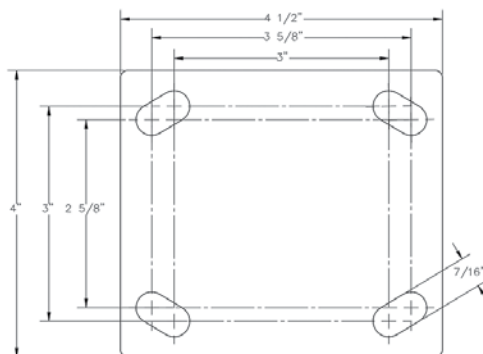

model
CST-BSS-6X2NY-R

MODEL NUMBER	CASTER SIZE	CAPACITY	OVERALL HEIGHT	TOP PLATE SIZE	CASTER RACEWAY	WEIGHT (POUND)
SWIVEL CASTERS						
CST-BSS-6X2NY-S	6" x 2"	1,764 lb.	7 1/2"	4" x 4 1/2"	Double	5.07
RIGID CASTERS						
CST-BSS-6X2NY-R	6" x 2"	1,764 lb.	7 1/2"	4" x 4 1/2"	--	4.19

CUSTOM-MADE CASTERS & WHEELS

Custom-Made Casters & Wheels are available upon request. Capacities available up to 65,000 lbs.
Often casters ship in 7 to 10 business days. Contact factory for details.

- Automotive • Aviation • Commercial • Food Service • Forged Steel • Gate Spring Loaded • Heat Resistant
- Laboratory • Medical • NSF Compliant • Pneumatic • ROHS Compliant • Scaffold • Stem • Zero Gravity



ECONOMICAL CASTERS

Thermoplastic Polyurethane Rubber (TPR) ★★

Thermoplastic polyurethane rubber casters provide low resistance when maneuvering with heavy loads. **Resistant to chemicals, acids, bases, alcohol, salts, and steam.** Gray tread color. Wheel core is constructed of polypropylene. CST-B23 90 ±5 Shore A / CST-B28 85 ±5 Shore A. Made in China.

- Resistant to chemicals, acids, bases, alcohol, salts, & steam
- Hardened Bearing Raceway
- Anti-Corrosive & Rust Resistant Finish
- Precision Ball Bearing



model CST-B23-2X1TPR-SWB model CST-B23-2X1TPR-S



48 Hours to Ship
model CST-B28-5X1TPR-S



model CST-B28-5X1TPR-R



model CST-B23-2X1TPR-S



model CST-B28-3X1PP-S



model CST-B28-4X1PP-SWB



model CST-C02-3X1CI-S



model CST-C02-3X1CI-SWB

MODEL NUMBER	CASTER SIZE	CAPACITY	OVERALL HEIGHT	TOP PLATE SIZE	HARDENED RACEWAY	WEIGHT (POUND)
SWIVEL CASTERS						
CST-B23-2X1TPR-S*⊕	2" x 4/5"	77 lb.	2 ⁵ / ₈ "	1 ⁷ / ₈ " x 2 ¹ / ₄ "	Double	0.34
CST-B28-4X1TPR-S⊕	4" x 1 ¹ / ₄ "	220 lb.	5 ¹ / ₄ "	2 ⁵ / ₈ " x 3 ³ / ₄ "	Double	1.69
CST-B28-5X1TPR-S⊕	5" x 1 ¹ / ₄ "	308 lb.	6 ¹ / ₄ "	2 ¹⁶ / ₂₅ " x 3 ³ / ₄ "	Double	1.92
RIGID CASTERS						
CST-B23-2X1TPR-R*⊕	2" x 4/5"	77 lb.	2 ⁵ / ₈ "	1 ⁷ / ₈ " x 2 ¹ / ₄ "	--	0.23
CST-B28-4X1TPR-R⊕	4" x 1 ¹ / ₄ "	220 lb.	5 ¹ / ₄ "	2 ⁵ / ₈ " x 3 ³ / ₄ "	--	1.18
CST-B28-5X1TPR-R⊕	5" x 1 ¹ / ₄ "	308 lb.	6 ¹ / ₄ "	2 ¹⁶ / ₂₅ " x 3 ³ / ₄ "	--	1.34
SWIVEL CASTER WITH BRAKE						
CST-B23-2X1TPR-SWB*⊕	2" x 4/5"	77 lb.	2 ⁵ / ₈ "	1 ⁷ / ₈ " x 2 ¹ / ₄ "	Double	0.37
CST-B28-4X1TPR-SWB⊕	4" x 1 ¹ / ₄ "	220 lb.	5 ¹ / ₄ "	2 ⁵ / ₈ " x 3 ³ / ₄ "	Double	1.91
CST-B28-5X1TPR-SWB⊕	5" x 1 ¹ / ₄ "	308 lb.	6 ¹ / ₄ "	2 ¹⁶ / ₂₅ " x 3 ³ / ₄ "	Double	2.20

*PLAIN BORE
CST-B28 MODELS HAVE A BEARING DUST COVER SEAL

Polypropylene ★★

Polypropylene casters are great for a variety of industries with their limited rolling resistance and ability to withstand rough environments. The construction is **non-staining and corrosion resistant** to a variety of outside substances. Swivel design allows the user to maneuver and change directions instantaneously. Wheel core is constructed of polypropylene. 100 ±5 Shore A (CST-B23-2X1PP-S 95 ±5 Shore A). Made in China.

- Hardened Bearing Raceway
- Anti-Corrosive & Rust Resistant Finish
- Rolls Smoothly Across Many Surfaces
- Encourages Time-Efficient Maneuvering of Products

MODEL NUMBER	CASTER SIZE	CAPACITY	OVERALL HEIGHT	TOP PLATE SIZE	HARDENED RACEWAY	WEIGHT (POUND)
SWIVEL CASTERS						
CST-B23-2X1PP-S***⊕	2" x 1 ³ / ₁₆ "	88 lb.	2 ⁵ / ₈ "	1 ⁷ / ₈ " x 2 ¹ / ₄ "	Double	0.29
CST-B28-3X1PP-S**⊕	3" x 1 ¹ / ₄ "	176 lb.	4 ¹ / ₁₆ "	2 ⁵ / ₈ " x 3 ³ / ₄ "	Double	1.43
CST-B28-4X1PP-S**⊕	4" x 1 ¹ / ₄ "	264 lb.	5 ¹ / ₈ "	2 ⁵ / ₈ " x 3 ³ / ₄ "	Double	1.69
RIGID CASTERS						
CST-B23-2X1PP-R***⊕	2" x 1 ³ / ₁₆ "	88 lb.	2 ⁵ / ₈ "	1 ⁷ / ₈ " x 2 ¹ / ₄ "	--	0.19
CST-B28-3X1PP-R**⊕	3" x 1 ¹ / ₄ "	176 lb.	4 ¹ / ₁₆ "	2 ⁵ / ₈ " x 3 ³ / ₄ "	--	1.32
CST-B28-4X1PP-R**⊕	4" x 1 ¹ / ₄ "	264 lb.	5 ¹ / ₈ "	2 ⁵ / ₈ " x 3 ³ / ₄ "	--	1.18
SWIVEL CASTER WITH TOTAL BRAKE						
CST-B23-2X1PP-SWB**/***⊕	2" x 1 ³ / ₁₆ "	88 lb.	2 ⁵ / ₈ "	1 ⁷ / ₈ " x 2 ¹ / ₄ "	Double	0.32
CST-B28-3X1PP-SWTB**⊕	3" x 1 ¹ / ₄ "	176 lb.	4 ¹ / ₁₆ "	2 ⁵ / ₈ " x 3 ³ / ₄ "	Double	2.65
CST-B28-4X1PP-SWTB**⊕	4" x 1 ¹ / ₄ "	264 lb.	5 ¹ / ₈ "	2 ⁵ / ₈ " x 3 ³ / ₄ "	Double	2.66

*SWIVEL CASTER WITH BRAKE / **PRECISION BALL BEARING / ***PLAIN BORE
CST-B28 MODELS HAVE A BEARING DUST COVER SEAL

Cast Iron ★★

Cast iron casters are a cost efficient way of getting industrial carts and dollies back to running smoothly. The units are **abrasion resistant** even when transporting substantial weight. Swivel model allows the user to change directions and maintain increased control over the device. Simple attachment for immediate use upon installation. Black tread color. Wheel core is constructed of cast iron. Made in China.

- Hardened Bearing Raceway
- Anti-Corrosive & Rust Resistant Finish
- NSF Compliant
- Roller Bearing
- All have a Wheel Axle Zerk Filling
- All have a Axle Wheel Zerk Fitting

MODEL NUMBER	CASTER SIZE	CAPACITY	OVERALL HEIGHT	TOP PLATE SIZE	HARDENED RACEWAY	WEIGHT (POUND)
SWIVEL CASTERS						
CST-C02-3X1CI-S⊕	3" x 1 ¹ / ₄ "	250 lb.	4 ¹ / ₄ "	3 ¹ / ₈ " x 4 ¹ / ₈ "	Double	3.00
RIGID CASTERS						
CST-C02-3X1CI-R⊕	3" x 1 ¹ / ₄ "	250 lb.	4 ¹ / ₄ "	3 ¹ / ₈ " x 4 ¹ / ₈ "	--	2.60
SWIVEL CASTER WITH BRAKE						
CST-C02-3X1CI-SWB⊕	3" x 1 ¹ / ₄ "	250 lb.	4 ¹ / ₄ "	3 ¹ / ₈ " x 4 ¹ / ₈ "	Double	3.15

ECONOMICAL CASTERS

Rubber ★

Rubber casters are a must have if **working in damp or corrosive environments**. The simple design and smooth finish ensure that the unit is easily cleanable. Transport loads from place to place with these **quiet-rolling** casters. Wheel core is constructed of black rubber. Made in China.

- Hardened Bearing Raceway
- Anti-Corrosive & Rust Resistant Finish
- Rolls Smoothly Across Many Surfaces
- Roller Bearing

MODEL NUMBER	CASTER SIZE	CAPACITY	OVERALL HEIGHT	TOP PLATE SIZE	HARDENED RACEWAY	WEIGHT (POUND)
SWIVEL CASTERS						
CST-B23-2X1RU-S**Ⓢ	2" x 1 ³ / ₁₆ "	75 lb.	2 ⁵ / ₈ "	1 ⁹ / ₁₀ " x 2 ⁷ / ₂₅ "	Double	0.40
CST-AP2-2X1R-SⓈ	2" x 1 ³ / ₁₆ "	125 lb.	2 ¹ / ₂ "	1 ⁷ / ₈ " x 2 ⁹ / ₁₆ "	Single	0.40
CST-B28-3X1RU-S**Ⓢ	3" x 1 ¹ / ₄ "	198 lb.	4"	2 ¹⁶ / ₂₅ " x 3 ³ / ₄ "	Double	1.58
RIGID CASTERS						
CST-B23-2X1RU-R**Ⓢ	2" x 1 ³ / ₁₆ "	75 lb.	2 ⁵ / ₈ "	1 ⁹ / ₁₀ " x 2 ⁷ / ₂₅ "	--	0.29
CST-AP2-2X1R-RⓈ	2" x 1 ³ / ₁₆ "	125 lb.	2 ¹ / ₂ "	1 ⁷ / ₈ " x 2 ⁹ / ₁₆ "	--	0.29
CST-B28-3X1RU-R**Ⓢ	3" x 1 ¹ / ₄ "	198 lb.	4"	2 ¹⁶ / ₂₅ " x 3 ³ / ₄ "	--	.99
SWIVEL CASTER WITH BRAKE						
CST-B23-2X1RU-SWB**Ⓢ	2" x 1 ³ / ₁₆ "	75 lb.	2 ⁵ / ₈ "	1 ⁹ / ₁₀ " x 2 ⁷ / ₂₅ "	Double	0.43
CST-AP2-2X1R-SWBⓈ	2" x 1 ³ / ₁₆ "	125 lb.	2 ¹ / ₂ "	1 ⁷ / ₈ " x 2 ⁹ / ₁₆ "	Single	0.45
CST-B28-3X1RU-SWTB**Ⓢ	3" x 1 ¹ / ₄ "	198 lb.	4"	2 ¹⁶ / ₂₅ " x 3 ³ / ₄ "	Double	1.92

*SWIVEL CASTER WITH TOTAL BRAKE / **DELTRIN BEARING
CST-B28 MODELS HAVE A BEARING DUST COVER SEAL

Mold-On-Rubber ★

Transport loads from place to place with these **quiet, shock-absorbing** casters. Ideal for industrial applications such as platform trucks, wire shelving, and other warehouse carts and trucks. Black tread color. Wheel core is steel. Made in China.

- Hardened Bearing Raceway
- Anti-Corrosive & Rust Resistant Finish
- Rolls Smoothly Across Many Surfaces
- Roller Bearing

MODEL NUMBER	CASTER SIZE	CAPACITY	OVERALL HEIGHT	TOP PLATE SIZE	HARDENED RACEWAY	WEIGHT (POUND)
SWIVEL CASTERS						
CST-MR-4/2-SⓈ	4" x 2"	350 lb.	5 ¹ / ₂ "	4" x 4 ¹ / ₂ "	Double	7
CST-MR-6/2-SⓈ	6" x 2"	450 lb.	7 ¹ / ₂ "	4" x 4 ¹ / ₂ "	Double	10
CST-MR-8/2-SⓈ	8" x 2"	500 lb.	9 ¹ / ₂ "	4" x 4 ¹ / ₂ "	Double	12
RIGID CASTERS						
CST-MR-4/2-RⓈ	4" x 2"	350 lb.	5 ¹ / ₂ "	4" x 4 ¹ / ₂ "	--	6
CST-MR-6/2-RⓈ	6" x 2"	450 lb.	7 ¹ / ₂ "	4" x 4 ¹ / ₂ "	--	8
CST-MR-8/2-RⓈ	8" x 2"	500 lb.	9 ¹ / ₂ "	4" x 4 ¹ / ₂ "	--	10
SWIVEL CASTER WITH BRAKE						
CST-MR-4/2-S-SWBⓈ	4" x 2"	350 lb.	5 ¹ / ₂ "	4" x 4 ¹ / ₂ "	Double	6
CST-MR-6/2-S-SWBⓈ	6" x 2"	450 lb.	7 ¹ / ₂ "	4" x 4 ¹ / ₂ "	Double	9

Polyurethane ★★

Polyurethane casters are the perfect asset for an assortment of commercial and non-commercial settings. The polyurethane construction lessens the amount of noise caused through travel across rough surfaces. It is **resistant to a variety of chemicals**. Dark gray tread color. Wheel core is made of polypropylene. 95 ±5 Shore A (CST-C22-4X1PU-S 90 ±5 Shore A). Made in China.

- Hardened Bearing Raceway
- Anti-Corrosive & Rust Resistant Finish
- Rolls Smoothly Across Many Surfaces
- Precision Ball Bearing

MODEL NUMBER	CASTER SIZE	CAPACITY	OVERALL HEIGHT	TOP PLATE SIZE	HARDENED RACEWAY	WEIGHT (POUND)
SWIVEL CASTERS						
CST-C22-4X1PU-S**Ⓢ	4" x 1 ¹ / ₄ "	250 lb.	5 ³ / ₁₆ "	2 ³ / ₄ " x 3 ³ / ₄ "	Double	2
CST-B28-5X1PU-SⓈ	5" x 1 ¹ / ₄ "	330 lb.	6 ¹ / ₄ "	2 ⁵ / ₈ " x 3 ³ / ₄ "	Double	1.93
RIGID CASTERS						
CST-B28-5X1PU-RⓈ	5" x 1 ¹ / ₄ "	330 lb.	6 ¹ / ₄ "	2 ⁵ / ₈ " x 3 ³ / ₄ "	--	1.40
SWIVEL CASTER WITH TOTAL BRAKE						
CST-B28-5X1PU-SWTBⓈ	5" x 1 ¹ / ₄ "	330 lb.	6 ¹ / ₄ "	2 ⁵ / ₈ " x 3 ³ / ₄ "	Double	2.32

*MAROON TREAD COLOR FOR CST-C22-4X1PU-S / **NSF COMPLIANT
CST-B28 MODELS HAVE A BEARING DUST COVER SEAL



model
CST-AP2-2X1R-S



model
CST-B28-3X1RU-S



model
CST-MR-6/2-S



model CST-MR-4/2-SWB



model
CST-B28-5X1PU-S



model
CST-C22-4X1PU-S

ECONOMICAL CASTERS



model CST-C44-6X2PU-S



48 Hours
to Ship



model CST-C44-6X2PU-SWB

Polyurethane ★★

Polyurethane casters are the perfect asset for an assortment of commercial and non-commercial settings. It is **resistant to a variety of chemicals**. The large capacity diminishes the number of trips needed to be taken, while reducing the amount of physical labor needed to transport products. The polyurethane construction lessens the amount of noise caused through travel across rough surfaces. Swivel design allows the user to maneuver and change directions instantaneously. Maroon tread color. Wheel core is polyolefin. 90 ±5 Shore A. Made in China.

- Resistant to a Variety of Chemicals
- Hardened Bearing Raceway
- Anti-Corrosive & Rust Resistant Finish
- NSF Compliant
- Roller Bearing
- Bearing Dust Cover Seals

MODEL NUMBER	CASTER SIZE	CAPACITY	OVERALL HEIGHT	TOP PLATE SIZE	HARDENED RACEWAY	WEIGHT (POUND)
SWIVEL CASTERS						
CST-C44-5X2PU-S	5" x 2"	700 lb.	6½"	4" x 4½"	Double	4.60
CST-C44-6X2PU-S	6" x 2"	750 lb.	7½"	4" x 4½"	Double	5.17
RIGID CASTERS						
CST-C44-5X2PU-R	5" x 2"	700 lb.	6½"	4" x 4½"	--	3.80
CST-C44-6X2PU-R	6" x 2"	750 lb.	7½"	4" x 4½"	--	4.37
SWIVEL CASTER WITH BRAKE						
CST-C44-5X2PU-SWB	5" x 2"	700 lb.	6½"	4" x 4½"	Double	5.20
CST-C44-6X2PU-SWB	6" x 2"	750 lb.	7½"	4" x 4½"	Double	5.50

ALL MODELS HAVE AXLE WHEEL ZERK FITTING
S & SWB MODELS SWIVEL RIG ZERK FITTING



model CST-E6-6X2PU-SWTB

48 Hours
to Ship



Polyurethane with Thread Guard ★★★

Polyurethane casters are the perfect asset for an assortment of commercial and non-commercial settings. The large capacity diminishes the number of trips needed to be taken while reducing the amount of physical labor needed to transport products. The polyurethane construction lessens the amount of noise caused through travel across rough surfaces. It is **resistant to a variety of chemicals**. Swivel design allows the user to maneuver and change directions instantaneously. Orange tread color. Wheel core is made of polypropylene. 95 ±5 Shore A. Made in China.

- Thread Guard Provides Added Protection Against Debris & Corrosion
- Resistant to a Variety of Chemicals
- Precision Ball Bearing
- Hardened Bearing Raceway
- Anti-Corrosive Paint Finish
- S and SWTB have Swivel Rig Zerk Fitting

MODEL NUMBER	CASTER SIZE	CAPACITY	OVERALL HEIGHT	TOP PLATE SIZE	HARDENED RACEWAY	WEIGHT (POUND)
SWIVEL CASTERS						
CST-E6-6X2PU-S	6" x 2"	900 lb.	7½"	4" x 4½"	Double	5.18
CST-E6-8X2PU-S	8" x 2"	1,000 lb.	9½"	4" x 4½"	Double	6.54
RIGID CASTERS						
CST-E6-6X2PU-R	6" x 2"	900 lb.	7½"	4" x 4½"	--	4.16
CST-E6-8X2PU-R	8" x 2"	1,000 lb.	9½"	4" x 4½"	--	5.57
SWIVEL CASTER WITH TOTAL BRAKE						
CST-E6-6X2PU-SWTB	6" x 2"	900 lb.	7½"	4" x 4½"	Double	6.33
CST-E6-8X2PU-SWTB	8" x 2"	1,000 lb.	9½"	4" x 4½"	Double	7.72

S & SWTB MODELS HAVE SWIVEL RIG ZERK FITTING

ECONOMICAL CASTERS

Glass-Filled Nylon ★

These glass filled nylon casters are constructed of a thermoplastic compound that is perfect for industrial and institutional applications. **Resistant to most chemicals, salts, solvents, and steam.** This tread **does not absorb water and is non-marking.** Black tread color. Wheel core is glass-filled nylon. 65 ±5 Shore D. Made in China.

- Resistant to most Chemicals, Salts, Solvents, and Steam
- Anti-Corrosive & Rust Resistant Finish
- NSF Compliant
- Hardened Bearing Raceway
- Roller Bearing
- Bearing Dust Cover Seals

48 Hours
to Ship

New



model CST-C44-8X2GFN-S



model CST-C44-6X2GFN-SWB

MODEL NUMBER	CASTER SIZE	CAPACITY	OVERALL HEIGHT	TOP PLATE SIZE	HARDENED RACEWAY	WEIGHT (POUND)
SWIVEL CASTERS						
CST-C44-4X2GFN-SⓈ	4" x 2"	650 lb.	5½"	4" x 4½"	Double	3.96
CST-C44-6X2GFN-SⓈ	6" x 2"	1,050 lb.	7½"	4" x 4½"	Double	5.07
CST-C44-8X2GFN-SⓈ	8" x 2"	1,100 lb.	9½"	4" x 4½"	Double	6.39
RIGID CASTERS						
CST-C44-4X2GFN-RⓈ	4" x 2"	650 lb.	5½"	4" x 4½"	--	3.25
CST-C44-6X2GFN-RⓈ	6" x 2"	1,050 lb.	7½"	4" x 4½"	--	4.27
CST-C44-8X2GFN-RⓈ	8" x 2"	1,100 lb.	9½"	4" x 4½"	--	5.56
SWIVEL CASTER WITH BRAKE						
CST-C44-4X2GFN-SWBⓈ	4" x 2"	650 lb.	5½"	4" x 4½"	Double	4.27
CST-C44-6X2GFN-SWBⓈ	6" x 2"	1,050 lb.	7½"	4" x 4½"	Double	5.40
CST-C44-8X2GFN-SWB*Ⓢ	8" x 2"	1,100 lb.	9½"	4" x 4½"	Double	6.39
CST-C44-8X2GFN-4PSL**Ⓢ	8" x 2"	1,100 lb.	9½"	4" x 4½"	Double	7.03

*SWIVEL CASTER WITH TOTAL BRAKE / **FOUR POSITION SWIVEL CASTER WITH LOCK
SWIVEL CASTERS & SWIVEL CASTERS WITH BRAKE FEATURE SWIVEL RIG ZERK FITTING & AXLE WHEEL ZERK FITTING
RIGID CASTERS FEATURE AXLE WHEEL ZERK FITTING

Phenolic ★

Phenolic wheels have a high resistance to impact damage, while providing protection for floors in commercial and industrial settings. **Resistant to water, oil, and grease.** It is also **spark resistant** and operates in a **wide temperature range.** Black tread color. Wheel core is phenolic. 100 Shore A. Made in China.

- Resistant to Water, Oil, and Grease
- Anti-Corrosive Paint Finish
- Roller Bearing
- Hardened Bearing Raceway
- Double Welds on Inside & Outside of Fork Mounts

48 Hours
to Ship



model CST-D-5X2PH-S



model CST-D-5X2PH-SWB

MODEL NUMBER	CASTER SIZE	CAPACITY	OVERALL HEIGHT	TOP PLATE SIZE	HARDENED RACEWAY	WEIGHT (POUND)
SWIVEL CASTERS						
CST-D-5X2PH-SⓈ	5" x 2"	1,000 lb.	6½"	4" x 4½"	Double	5.2
RIGID CASTERS						
CST-D-5X2PH-RⓈ	5" x 2"	1,000 lb.	6½"	4" x 4½"	--	4.3
SWIVEL CASTER WITH BRAKE						
CST-D-5X2PH-SWBⓈ	5" x 2"	1,000 lb.	6½"	4" x 4½"	Double	5.55

SWIVEL MODEL HAS A SWIVEL RIG ZERK FITTING
SWIVEL WITH BRAKE MODEL HAS A SWIVEL RIG ZERK FITTING & AXLE WHEEL ZERK FITTING

Cast Iron ★★☆☆

Cast iron casters are a cost efficient way of getting industrial carts and dollies back to running smoothly. The units are **abrasion resistant even when transporting substantial weight.** Swivel model allows the user to change directions and maintain increased control over the device. Simple attachment for immediate use upon installation. Gray tread color. Wheel core is cast iron. 100 Shore A. Made in China.

- Bearing Dust Cover Seals
- Double Welds on Inside & Outside of Fork Mounts
- Anti-Corrosive & Rust Resistant Finish
- Hardened Bearing Raceway
- Roller Bearing

48 Hours
to Ship



model CST-B29-4X2CI-S

MODEL NUMBER	CASTER SIZE	CAPACITY	OVERALL HEIGHT	TOP PLATE SIZE	HARDENED RACEWAY	WEIGHT (POUND)
SWIVEL CASTERS						
CST-B29-4X2CI-SⓈ	4" x 2"	1,102 lb.	5⅝"	4" x 4½"	Double	5.99
RIGID CASTERS						
CST-B29-4X2CI-RⓈ	4" x 2"	1,102 lb.	5⅝"	4" x 4½"	--	5.22

SWIVEL MODEL HAS A SWIVEL RIG ZERK FITTING & AXLE WHEEL ZERK FITTING
RIGID MODEL HAS AXLE WHEEL ZERK FITTING

ECONOMICAL CASTERS

Polyurethane ★★ ★

Polyurethane casters are the perfect asset for an assortment of commercial and non-commercial settings. The large capacity diminishes the number of trips needed, while reducing the amount of physical labor needed to transport products. The polyurethane construction lessens the amount of noise caused through travel across rough surfaces. These casters are **resistant to a variety of chemicals**. An assortment of wheel core materials are available. 90 ±5 Shore A. Made in China.



48 Hours
to Ship

New

model CST-B29-6X2PUA-S

- Aluminum Core for Better Corrosion Resistance
- Double Welds on Inside & Outside of Fork Mounts
- Anti-Corrosive & Rust Resistant Finish
- Bearing Dust Cover Seals
- Precision Ball Bearing
- Hardened Bearing Raceway



New

model CST-B29-8X2PUA-SWTB

POLYURETHANE (ORANGE TREAD) ON ALUMINUM WHEEL CORE

MODEL NUMBER	CASTER SIZE	CAPACITY	OVERALL HEIGHT	TOP PLATE SIZE	HARDENED RACEWAY	WEIGHT (POUND)
SWIVEL CASTERS						
CST-B29-6X2PUA-S [Ⓢ]	6" x 2"	1,212 lb.	7½"	4" x 4½"	Double	8.0
CST-B29-8X2PUA-S [Ⓢ]	8" x 2"	1,543 lb.	9 ⁷ / ₁₆ "	4" x 4½"	Double	10.66
RIGID CASTERS						
CST-B29-6X2PUA-R [Ⓢ]	6" x 2"	1,212 lb.	7½"	4" x 4½"	--	7.06
CST-B29-8X2PUA-R [Ⓢ]	8" x 2"	1,543 lb.	9 ⁷ / ₁₆ "	4" x 4½"	--	9.9
SWIVEL CASTER WITH TOTAL BRAKE						
CST-B29-6X2PUA-SWTB [Ⓢ]	6" x 2"	1,212 lb.	7½"	4" x 4½"	Double	8.6
CST-B29-8X2PUA-SWTB [Ⓢ]	8" x 2"	1,543 lb.	9 ⁷ / ₁₆ "	4" x 4½"	Double	11.4

SWIVEL & SWIVEL WITH TOTAL BRAKE HAVE A SWIVEL RIG ZERK FITTING

★★★★

- Hardened Bearing Raceway
- Rolls Smoothly Across Many Surfaces
- Bearing Dust Cover Seals
- 90 ±5 Shore A
- Double Welds on Inside & Outside of Fork Mounts
- Anti-Corrosive & Rust Resistant Finish
- The Swivel Casters have a Swivel Rig Zerk Fitting



48 Hours
to Ship

New

model CST-B29-8X2PU-S

POLYURETHANE (YELLOW TREAD) STEEL WHEEL CORE

MODEL NUMBER	CASTER SIZE	CAPACITY	OVERALL HEIGHT	TOP PLATE SIZE	HARDENED RACEWAY	WEIGHT (POUND)
SWIVEL CASTERS						
CST-B29-6X2PU-S* [Ⓢ]	6" x 2"	1,234 lb.	7½"	3 ⁷ / ₈ " x 4½"	Double	7.05
CST-B29-8X2PU-S** [Ⓢ]	8" x 2"	1,477 lb.	9½"	4" x 4½"	Double	9.40
RIGID CASTERS						
CST-B29-6X2PU-R* [Ⓢ]	6" x 2"	1,234 lb.	7½"	3 ⁷ / ₈ " x 4½"	--	6.29
CST-B29-8X2PU-R** [Ⓢ]	8" x 2"	1,477 lb.	9½"	4" x 4½"	--	8.70

*PRECISION BALL BEARING / **ROLLER BEARING

★★★★

- Bearing Dust Cover Seals
- Double Welds on Inside & Outside of Fork Mounts
- Anti-Corrosive & Rust Resistant Finish
- 95 ±5 Shore A
- Hardened Bearing Raceway
- NSF Compliant
- Roller Bearing



48 Hours
to Ship

model CST-C44-8X2PU-S

POLYURETHANE (MAROON TREAD) CAST IRON WHEEL CORE

MODEL NUMBER	CASTER SIZE	CAPACITY	OVERALL HEIGHT	TOP PLATE SIZE	HARDENED RACEWAY	WEIGHT (POUND)
SWIVEL CASTERS						
CST-C44-8X2PU-S [Ⓢ]	8" x 2"	1,250 lb.	9½"	4" x 4½"	Double	9.5
RIGID CASTERS						
CST-C44-8X2PU-R [Ⓢ]	8" x 2"	1,250 lb.	9½"	4" x 4½"	--	8.8
SWIVEL CASTER WITH BRAKE						
CST-C44-8X2PU-SWB [Ⓢ]	8" x 2"	1,250 lb.	9½"	4" x 4½"	Double	9.9

S & SWB HAVE A SWIVEL RIG ZERK FITTING & AXLE WHEEL ZERK FITTING
RIGID HAVE A AXLE WHEEL ZERK FITTING



New

model CST-C44-8X2PU-SWB

ECONOMICAL CASTERS

Phenolic ★

Phenolic wheels have a **high resistance to impact**, while providing protection for floors in commercial and industrial settings. **Resistant to water, oil, and grease**. It is also **spark resistant and operates in a wide temperature range**. Black tread color. Wheel core is phenolic. Made in China.

- Ideal for Heavy Duty Equipment
- Ideal for Industrial, Commercial and Warehouse Use
- Resistant to Water, Oil, and Grease
- Hardened Bearing Raceway
- Anti-corrosive Paint Finish
- Double Welds on Inside & Outside of Fork Mounts
- Roller Bearing
- CST-D-6X2PH-S has Swivel Rig Zerk Fitting
- CST-D-6X2PH-SWB has Swivel Rig Zerk Fitting and Axle Wheel Zerk Fitting

48 Hours
to Ship

New



model CST-D-6X2PH-S



model CST-D-6X2PH-SWB

MODEL NUMBER	CASTER SIZE	CAPACITY	OVERALL HEIGHT	TOP PLATE SIZE	HARDENED RACEWAY	WEIGHT (POUND)
SWIVEL CASTER						
CST-D-6X2PH-S [Ⓢ]	6" x 2"	1,200 lb.	7½"	4" x 4½"	Double	6.0
CST-PH-F-8/3-S [Ⓢ]	8" x 3"	2,500 lb.	10½"	4½" x 6¼"	Double	14
RIGID CASTER						
CST-D-6X2PH-R [Ⓢ]	6" x 2"	1,200 lb.	7½"	4" x 4½"	--	5.15
CST-PH-F-8/3-R [Ⓢ]	8" x 3"	2,500 lb.	10"	4½" x 6¼"	--	14
FOUR POSITION SWIVEL CASTER WITH LOCK						
CST-D-6X2PH-SWB* [Ⓢ]	6" x 2"	1,200 lb.	7½"	4" x 4½"	Double	6.4
CST-PH-F-8/3-S-4PSL [Ⓢ]	8" x 3"	2,500 lb.	10½"	4½" x 6¼"	Double	17

*SWIVEL WITH BRAKE

Cast Iron ★★☆☆

Cast iron casters are a cost efficient way of getting industrial carts and dollies back to running smoothly. The units are **abrasion resistant even when transporting substantial weight**. Swivel model allows the user to change directions and maintain increased control over the device. Simple attachment for immediate use upon installation. Gray tread color. Wheel core is cast iron. 100 Shore A. Made in China.

- Bearing Dust Cover Seals
- Double Welds on Inside & Outside of Fork Mounts
- Anti-Corrosive & Rust Resistant Finish
- Hardened Bearing Raceway
- Roller Bearing

48 Hours
to Ship



model CST-B29-5X2CI-S



model CST-B29-5X2CI-R

New

MODEL NUMBER	CASTER SIZE	CAPACITY	OVERALL HEIGHT	TOP PLATE SIZE	HARDENED RACEWAY	WEIGHT (POUND)
SWIVEL CASTERS						
CST-B29-5X2CI-S [Ⓢ]	5" x 2"	1,322 lb.	6½"	4" x 4½"	Double	6.91
CST-B29-6X2CI-S [Ⓢ]	6" x 2"	1,543 lb.	7½"	4" x 4½"	Double	8.16
RIGID CASTERS						
CST-B29-5X2CI-R [Ⓢ]	5" x 2"	1,322 lb.	6½"	4" x 4½"	--	6.13
CST-B29-6X2CI-R [Ⓢ]	6" x 2"	1,543 lb.	7½"	4" x 4½"	--	7.47

SWIVEL CASTERS HAVE SWIVEL RIG ZERK FITTING AND AXLE WHEEL ZERK FITTING
RIGID CASTERS HAVE AXLE WHEEL ZERK FITTING

WHEELS

Made in GERMANY



model WHL-AVLE-10SR-ZZ



model WHL-AVLE-10SR-RB

New

Solid Rubber (Never Flat Rubber Wheels)

These high-quality wheels are composed of two components: super elastic solid rubber and a hard rubber core. The **tread is abrasion resistant with reinforced steel wire**. These wheels provide great operational comfort, good floor preservation, and resists many aggressive chemical substances. The advantage of these wheels compared to standard pneumatic is they are puncture proof, maintenance-free, and allow for precise steering. With a reduced load capacity, maximum speeds of up to 15 mph are permissible. 70 Shore A. Made in Germany.

- Hub Type: Offset
- Hub Color: Silver
- Hub Finish: Zinc
- Hub Length: 2 1/4"
- Hub Material: Steel
- Zerk Fittings

4 YEAR WARRANTY

MODEL NUMBER	WHEEL DIAMETER	WHEEL WIDTH	AXLE DIAMETER	CAPACITY	WEIGHT (POUND)
WHL-AVLE-10SR-ZZ	10"	3 11/32"	1"	1,000 lb.	11.6
WHL-AVLE-10SR-RB	10"	3 11/32"	3/4"	1,000 lb.	11.5

Made in GERMANY



model WHL-AP-10PNU

New

Pneumatic

Pneumatic wheels provide the highest operational comfort and floor preservation. They are also **resistant to most aggressive chemicals**. With a reduced load capacity, maximum speeds of up to 10 mph are permissible. 70° Shore A. Made in Germany.

- Hub Type: Offset
- Hub Color: Silver
- Hub Finish: Zinc
- Hub Length: 2 1/4"
- Hub Material: Steel

4 YEAR WARRANTY

MODEL NUMBER	WHEEL DIAMETER	WHEEL WIDTH	AXLE DIAMETER	CAPACITY	WEIGHT (POUND)
WHL-AP-10PNU	10 7/32"	3 11/32"	3/4"	330 lb.	4.35



model SAW-10

Shock-Absorbing Wheels

The special design for **shock absorption properties** prevents wheels from bouncing like standard pneumatic wheels. Ideal for transporting loads down stairs. Solid black molded rubber tread **will never go flat**. Steel hubs for maximum strength. Precision bearings with 5/8" inside diameter.

- Great for Rough Terrain & Uneven Surfaces
- Large Capacity Capable of Moving Heavy Loads
- Rolls Quietly in Noise Sensitive Areas
- Long Lasting Throughout Adverse Condition

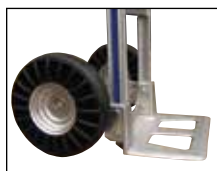

48 Hours to Ship

MODEL NUMBER	DIAMETER	HUB STYLE	CAPACITY	WEIGHT (POUND)
SAW-10	10"	OFFSET - FOR HAND TRUCKS	330 lb.	6
SAW-16	16"	SYMMETRIC - FOR WHEEL BARREL	330 lb.	14

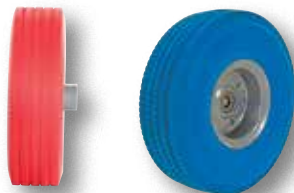

48 Hours to Ship

URETHANE SOLID FOAM

Urethane Solid Foam Wheels

The wheel is made of polyurethane, which has a greater load-bearing capacity than rubber. These **won't puncture or go flat** and are **resistant to corrosion and wear**. The sawtooth tread pattern provides traction. This wheel is intended for use in professional and industrial environments.

- Solid Urethane Foam Wheel will Never Go Flat
- Good for Any Terrain or Uneven Surface
- Offset Steel Hub is Great for use on Hand Trucks
- Resistant to Water, Oil, Dirt, Acid & Alkali

MODEL NUMBER	DIAMETER	COLOR	CAPACITY	WEIGHT (POUND)
UFBK-10-WHL-58	10" HIGH WITH 5/8" BEARING	BLACK	300 lb.	4
UFRD-10-WHL-58	10" HIGH WITH 5/8" BEARING	RED	300 lb.	4
UFYL-10-WHL-58	10" HIGH WITH 5/8" BEARING	YELLOW	300 lb.	4
UFBL-10-WHL-58	10" HIGH WITH 5/8" BEARING	BLUE	300 lb.	4
UFBK-16-WHL-58	16" HIGH WITH 5/8" BEARING	BLACK	300 lb.	10

CASTER ACCESSORIES

Adjustable Height Floor Locks

These one of a kind floor locks include an adjustable height foot pad that will work on carts with different caster heights. The adjustable height feature provides uniform locking and safety unlocking force for better ergonomic operation. This feature also keeps the floor lock working properly as spring and pads wear over time. Height is adjustable by turning the bottom pad. The bottom pad includes suction-cups for extra grip.



model FL-ADJ-810



Suction cup bottom pad

MODEL NUMBER	RETRACTED HEIGHT	EXTENDED HEIGHT	USED WITH CASTER SIZE	WEIGHT (POUND)
STEEL CONSTRUCTION				
FL-ADJ-46Ⓢ	5½" to 7¼"	6¼" to 8"	4" - 6"	7
FL-ADJ-810Ⓢ	6¼" to 9½"	8¼" to 11½"	6" - 8"	9
STAINLESS STEEL CONSTRUCTION				
FL-ADJ-46-SSⓈ	5½" to 7¼"	6¼" to 8"	4" - 6"	7
FL-ADJ-810-SSⓈ	6¼" to 9½"	8¼" to 11½"	6" - 8"	9

Low Profile Floor Lock

The lowest-profile floor lock available on the market today. Features adjustable-height pad for precision and wearability, simply bolt to bottom of cart. Foot operated. Heavy-duty cast steel construction.

MODEL NUMBER	RETRACTED HEIGHT	EXTENDED HEIGHT	WEIGHT (POUND)
FL-LK-LPⓈ	3¾"	4 ⁹ / ₁₆ "	6



model FL-LK-LP

General Purpose Floor Locks

Floor Locks may be used on platform trucks, fixture dollies, or equipment with casters. Simple foot pressure immobilizes equipment. Locks when large friction face is pressed against the floor. To release; simply kick release rod. Brake is independent of casters and can be installed to any convenient location on the cart.

Vertical mounting plate designed to mount to sides of carts and other portable products. The spring loaded pad accommodates uneven floors. Units mount with pad 1½" off the floor when retracted.

MODEL NUMBER	RETRACTED HEIGHT	EXTENDED HEIGHT	USED WITH CASTER SIZE	WEIGHT (POUND)
FL-LK-4EⓈ	4 ⁷ / ₈ "	5 ⁵ / ₈ "	4"	5
FL-LK-5EGⓈ	6"	7"	5"	8
FL-LK-5XⓈ	4½"	5 ⁵ / ₈ "	5"	9
FL-LK-6EHⓈ	7"	8"	6"	7
FL-LK-6EMⓈ	6¾"	7½"	6"	5
FL-LK-6ELⓈ	6½"	7¼"	6"	5
FL-LK-7XⓈ	6¼"	7¼"	6"	11
FL-LK-7GⓈ	6¼"	7¾"	6"	11
FL-LK-8EHⓈ	9½"	10½"	8"	8
FL-LK-8EMⓈ	9½"	10 ¹ / ₈ "	8"	5
FL-LK-8ELⓈ	8¾"	9½"	8"	5
FL-LK-10Ⓢ	8 ⁷ / ₈ "	9 ¹⁵ / ₁₆ "	8"	16
FL-LK-SⓈ	7"	8 ³ / ₁₆ "	6"	6
FL-LK-SMR-LⓈ	15 ¹⁵ / ₁₆ "	10" / 13 ⁷ / ₈ "	(2" of Travel)	7
FL-LK-SMR-RⓈ	15 ¹⁵ / ₁₆ "	10" / 13 ⁷ / ₈ "	(2" of Travel)	7
STAINLESS STEEL CONSTRUCTION				
FL-LK-SMR-SS-L	15 ¹⁵ / ₁₆ "	10" / 13 ⁷ / ₈ "	(2" of Travel)	7
FL-LK-SMR-SS-R	15 ¹⁵ / ₁₆ "	10" / 13 ⁷ / ₈ "	(2" of Travel)	7



model FL-LK-4E



model FL-LK-10

SIDE MOUNTED FLOOR LOCK
model FL-LK-SMR-L

CASTER ACCESSORIES



model FL-CFL-4



Economical Floor Locks

Our economical floor locks help to stabilize mobile equipment during loading and unloading. They are perfect for keeping carts, trucks, work benches, and other portable equipment stationary. All of these floor locks are spring loaded and offer a non-skid rubber foot pad to keep equipment in place. The heavy-duty steel construction. 2,000 pounds maximum capacity.

MODEL NUMBER	RETRACTED HEIGHT	EXTENDED HEIGHT	USE WITH CASTER SIZE	TOP PLATE DIMENSIONS	WEIGHT (POUND)
FL-CFL-4Ⓢ	5.09"	6"	4"	4" x 4½"	3.25
FL-CFL-5Ⓢ	5.75"	6.81"	5"	4" x 4½"	3.36
FL-CFL-6Ⓢ	6.77"	7.83"	6"	4" x 4½"	3.40
FL-CFL-8Ⓢ	8.74"	9.8"	8"	4" x 4½"	3.49

model FL-LKH-6



model FL-LKL-5



Polyurethane Floor Locks

Floor Locks are ideal for maintenance and construction facilities. These floor locks are designed to create a stable environment, while decreasing the chance of jostling or slight movement. They are constructed of steel with a thermoplastic polyurethane base. To use, place the unit close to a desired wheel or caster and raise until tension is built. Once secured, a simple locking device can be activated by applying pressure to the foot pedal.

MODEL NUMBER	RETRACTED HEIGHT	EXTENDED HEIGHT	USED WITH CASTER SIZE	WEIGHT (POUND)
FL-LKH-4Ⓢ	4 ⁵ / ₈ "	5 ³ / ₄ "	4"	4
FL-LKH-5Ⓢ	5 ⁷ / ₁₆ "	6 ⁵ / ₈ "	5"	5
FL-LKH-6Ⓢ	6 ⁷ / ₁₆ "	7 ⁵ / ₈ "	6"	5
FL-LKH-8Ⓢ	8 ³ / ₈ "	9 ³ / ₈ "	8"	5
FL-LKL-3Ⓢ	3 ⁵ / ₈ "	4 ¹ / ₄ "	3"	2
FL-LKL-4Ⓢ	4 ¹ / ₂ "	5 ¹ / ₄ "	4"	2
FL-LKL-5Ⓢ	5 ¹ / ₂ "	6 ¹ / ₄ "	5"	2

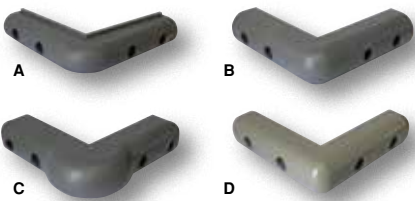

Corner, Surface Guards, and Bumpers

Reduce damage to walls, furniture, and machinery from cart and platform truck impact. Thermoplastic rubber construction with steel insert provides impact absorption. Easily attaches to any steel, aluminum, wood, or plastic surface. Mounting hardware not included.

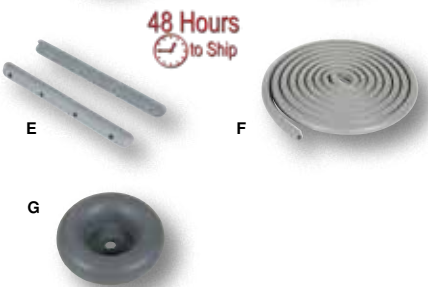

TYPE	MODEL NUMBER	STYLE	WIDTH	LENGTH	HEIGHT	THICKNESS	QTY. PER CARTON	WEIGHT (POUND)
A	CB-1Ⓢ	CORNER	3 ¹ / ₈ "	3 ¹ / ₈ "	5 ⁵ / ₈ "	5 ⁵ / ₈ "	28	4
B	CB-2Ⓢ	CORNER	3 ¹⁵ / ₁₆ "	3 ¹⁵ / ₁₆ "	1 ¹ / ₁₆ "	1 ¹ / ₁₆ "	16	5
C	CB-3Ⓢ	CORNER	4 ¹ / ₄ "	4 ¹ / ₄ "	1 ¹ / ₁₆ "	1 ¹ / ₁₆ "	12	4
D	CB-4Ⓢ	CORNER	4"	4"	1"	7 ⁷ / ₈ "	20	5
E	SB-12Ⓢ	EDGE	--	12"	1 ³ / ₁₆ "	1 ³ / ₁₆ "	12	5
F	EB-1Ⓢ	EDGE	1 ¹ / ₁₆ "	240"	1 ⁵ / ₁₆ "	5 ⁵ / ₃₂ "	1	11
G	RB-1Ⓢ	ROUND	3 ¹ / ₄ " DIAMETER, 5 ⁵ / ₁₆ " BORE				16	5