



LYON[®]

LOCKER SPECIFIER GUIDE

CONTENTS

2 - 3	Locker Ordering
4 - 5	Standard Lockers
6 - 7	Heavy-Duty Corridor Lockers
8 - 9	Heavy-Duty Lockers
10 - 11	Heavy-Duty Ventilated Lockers
12 - 13	All-Welded Lockers
14 - 15	All-Welded Extreme Lockers
16 - 17	Victory Lockers
18 - 19	Valor Lockers
20 - 21	TA-50 Lockers
22	Command Gear Lockers
23	Collegiate Lockers
24 - 25	Employee Lockers
26	Locker Room Benches
27 -29	Finishing Accessories
30	Anchoring and Bases
31	Resources
32 - 33	ADA Locker Guidelines
34	Optional Upgrades
35	Powder Coat

Application	Page	Locker Type
Elementary School Corridor	4	Standard
Middle/Junior High High School Corridor	4	Standard
	6	Heavy-Duty Corridor
	8	Heavy-Duty
Middle/Junior High High School Locker Room	4	Standard - P.E.
	6	Heavy-Duty Corridor
	8	Heavy-Duty - P.E./Team
	12	All-Welded
	14	All-Welded Extreme
	16	Victory, Team
	23	Collegiate, Team
College or University	4	Standard - General Use
	8	Heavy-Duty - General/Team
	16	Victory, Team
	23	Deluxe Collegiate, Team
Industrial Locker Room	4	Standard
	8	Heavy-Duty
	24	Employee
Health Club Locker Room	4	Standard, Value
	8	Heavy-Duty, Durability
Recreational Center	4	Standard, Value
	8	Heavy-Duty, Durability
Office Area	4	Standard
	24	Employee

ASSEMBLY

Unassembled	Unassembled lockers include nuts and bolts to be assembled in the field. These lockers take up less space in shipping.
Assembled	Assembled lockers are factory assembled with pop rivets in groups of 1, 2, or 3 frames.
All-Welded	All-welded lockers are welded in groups of 1, 2, or 3 frames.

LYON - WHEN QUALITY AND DELIVERY COUNT

Lyon has long been America's leading manufacturer of quality steel lockers for schools, hospitals, and industry. You can find Lyon lockers in virtually every city and town in America.

The familiar number plate on each Lyon locker door represents our commitment to both quality and product innovation for generations of students and workers alike. Lyon lockers have been the industry standard for more than a century.

COMPARISON TABLE

		Standard	Heavy-Duty Corridor	Heavy-Duty	Heavy-Duty Ventilated	All-Welded	All-Welded Extreme
COLOR	Door & Frame	Premier Color	Premier Color	Premier Color	Premier Color	Premier Color	Premier Color
	Body Parts	Putty	Putty	Putty	Matches Door & Frame	Matches Door & Frame	Matches Door & Frame
ASSEMBLY OPTION	Unassembled	Yes	Yes	Yes	Yes	-	-
	Riveted Assembly	Yes	Yes	Yes	Yes	-	-
	Welded	-	-	-	-	Yes	Yes
GAUGE	Door	16-gauge	14-gauge	14-gauge	14-gauge	14-gauge	14-gauge w/ 18-gauge Reinforcement
	Frame	16-gauge	16-gauge	16-gauge	16-gauge	16-gauge	16-gauge
	Body	24 ga. Body	24 ga. Body	16 ga. Body 18 ga. Back	16 ga. Body 18 ga. Back	16 ga. Body 18 ga. Back	16 ga. Body 18 ga. Back w/ Reinforced Bottom
	Hinges	5 Knuckle 2" Hinge	5 Knuckle 2" Hinge	5 Knuckle 2" Hinge	5 Knuckle 2" Hinge	5 Knuckle 2" Hinge	Full Height Continuous
	Ventilation	Standard Louvers	Standard Louvers	Standard Louvers	Diamond Perforations	Standard Louvers	Standard Louvers

See locker pages for more details

LOCKER ORDERING

Locker Size*	Width: 12 15 18 21
	Depth: 12 15 18 21 24
	Height: 12 15 18 20 24 30 36 48 60 72
Locker Type	Standard Heavy-Duty Specialty
Assembly	Unassembled Assembled All-Welded
Openings Per Frame (Tier)	1 2 3 4 5 6 10
Shelves	Gauge: 16 20 24
Reinforced Bottom	Gauge: 16 20 24
Locker Top	Flat Individual Slope Hood Continuous Sloping Hood
Locker Legs	No Legs 6" High Legs
Base Type	None Z Base Closed Base
Ventilation	Standard Louvers No Louvers Mini-Louvers Diamond Perforations
Handle Type	Recessed with Lockbar Single Point Latch Box Locker Pull Handle
Lock Type	No Locks Built-In Combination Built-In Key Control Combination Padlock Key Control Padlock Digital Locks
Color	Lyon Premier Colors Antimicrobial Finish Special Color

* See locker pages for available combinations



STANDARD LOCKER FEATURES

- Locker includes door and frame in one of Lyon's premier colors and body parts in Putty
- Door frames are formed by overlapping and welding the junction between the horizontal and vertical members to form a rigid structure that fully frames the door
- Door frames include integral full height 16-gauge door strikes to reinforce door edges
- One piece doors formed from 16-gauge prime, high grade class 1 steel
- Soft rubber bumpers, at door jamb locations, cushion door slams
- Full loop hinges are inserted through slots in the door and frame to maintain alignment and increase strength
- Three latch points on single tier doors and two on double and triple tier doors
- Double tier and triple tier lockers feature an intermediate cross member (ICM) between the doors
- Lockbars feature nano roller latching fingers that engage 12-gauge door jambs for maximum security
- Stainless steel recessed handle is standard on single, double, and triple tier lockers
- Pull handle is standard on lockers 4 tier and higher

CONFIGURATIONS



TIER	FRAME WIDTH	LOCKER DEPTH	NOMINAL DOOR HEIGHT*
Single	12 15 18	12 15 18 21 24	37-1/2 48-5/8 60 72
Double	12 15 18	12 15 18 21 24	30 36
Triple	12 15	12 15 18 21	20 24
Four	12 15	12 15 18 21	15 18
Five	12 15	12 15 18 21	12
Six	12 15	12 15 18 21	10 12

*Add 6" to overall height for legs when included

HANDLES



STAINLESS STEEL RECESSED HANDLE

Standard on single, double and triple-tier lockers with lockbar.

One piece recessed handle pockets add strength to the handle area and eliminate the vulnerable seams of formed handles. The lift handle includes a hasp that can be secured with a user provided padlock.



PULL HANDLE

Standard on multiple tier lockers. A built-in padlock loop easily accepts a user provided padlock.

LEGS



6" HIGH LEGS

Optional 6" high legs provide additional toe room below the locker door. Front legs are a welded piece of the locker frame. Rear legs are adjustable to insure a level installation.

STANDARD

SPECIFICATION SUMMARY

- 16-gauge one piece door
- 16-gauge frame
- 24-gauge body parts
- Full loop type hinges
- Secure multi-point locking system
- Stainless steel recessed handles
- Built-in padlock loop
- Available factory assembled or unassembled

POWDER COAT FINISH

Door and frame shall be painted in one of Lyon's premier color options. Body parts shall be Putty.

Option available to paint body parts to match door and frame.

MATERIAL

Prime, high grade class 1 mild annealed, cold-rolled steel free from surface imperfections. A.S.T.M.-A1008.

Bolts to be zinc plated or subjected to other rust-retardant treatment.

UPGRADES

See pages 34 - 35 for more information on available upgrades such as:

- Alternate Handle Options
- Galvannealed Lockers
- Antimicrobial Paint

CSI formatted specifications available at lyonworkspace.com/architects

Note: There are certain sizes and/or types of lockers that are available in minimum quantity production runs only. Contact your Lyon factory representative for complete details.

BODY 24-gauge steel, flanged to give double thickness of metal at back vertical corners.

DOOR FRAME 16-gauge formed steel channels. Vertical members have an additional flange to form continuous door strike. Corners are lapped and welded into a rigid assembly. In addition, bottom cross members have tang at each end that fits through slot in rear flange of upright frame member to prevent twisting out of alignment. Top and bottom cross members provide support for front edge of locker top and locker bottom.

DOOR One-piece, 16-gauge steel on single, double and triple tier with both vertical edges formed into channel-shaped formation; top and bottom are flanged at a 90 degree angle. On multiple tier lockers the hinge side is formed into channel shaped formation with other three sides flanged at a 90 degree angle. Note: Box locker doors, up to and including 15" wide by 15" high, are 18-gauge unless specified otherwise.

VENTILATION Louvers shall be provided as follows:

LOCKER STYLE	LOUVERS
Single tier lockers - 12"w and over	Six 6" louvers top and bottom
Double tier lockers - 12"w and over	Six 6" louvers top and bottom
Triple tier lockers - 12"w and over	Two 6" louvers top and bottom
Multiple tier lockers - 12"w and 15"w	Three 3-1/2" louvers centered
Multiple tier lockers - 18"w and over	Four 6" louvers centered

DOOR JAMBS 48" and higher single tier lockers have three door jambs; double tier and triple tier lockers have two jambs welded to side of door frames to engage locking device. Design and gauge of jamb prevent freeing of locking device by prying. Each jamb has easily replaceable soft rubber bumpers.

HINGES shall not be less than 2" high, 18-gauge steel, 5 knuckle, full loop design forming double thickness on each leaf. Hinges are set in slot in door and frame and projection welded to frame and securely riveted to door. Hinge pins are spun over at ends to resist removal. Single-tier lockers 48", 60" and 72" high have three hinges. All other tiers have two hinges - all on right hand side of door. *Optional continuous hinge riveted to frame in lieu of knuckle hinges available.

QUIET LOCKING DEVICE The single tier locking device engages the frame at three points; double tier and triple tier at two points. The channel shaped locking device with full length reinforcing ribs are a quiet design utilizing nylon guide inserts to reduce metal to metal contact. The locking device includes a latch finger that engages the 12-gauge door jamb. The lockbar is enclosed on three sides and operate within the channel formation of the door. The locking device is pre-locking so mechanism can be locked in open position - door locking automatically when closed. An optional single point latch is available except on 9" wide lockers. Box lockers have one-point locking device with a 14-gauge lock clip for attaching padlock. Doors also provide a lock hole filler to permit use of built-in lock.

HANDLES On single, double and triple tier lockers, handles are stainless steel recessed. No moving parts are to operate against outside surface of locker. Padlock attachment is an integral part of lift which is attached directly to locking bar and protected by fixed handle housing. Handle provides a built-in padlock strike. The recessed handle is 4-1/8"w x 6-1/16"h x 1-1/4"d. Multiple tier lockers are equipped with a 16-gauge door pull with padlock attachment when not used with built-in locks.

SHELVES Single tier lockers have one 24-gauge shelf approximately 9" below top. Flanged on all four sides for strength with the front flange turned 45 degrees for safety and attached at no less than two points through each side flange. Only single tier lockers 48" and taller have shelves.

COAT HOOKS Single tier, double tier and triple tier lockers have one double prong hook and three single prong wall hooks. 5/8" diameter coat rods are standard in 18" and 21" deep knocked down single tier lockers, replacing ceiling hook. All hooks are zinc plated or subjected to a comparable rust retardant treatment and attached with two nuts and bolts.

STANDARD FINISH Exposed steel parts are thoroughly cleaned, given a bonding and rust inhibitive phosphate treatment and then electrostatically sprayed with powder coat. NOTE: contact Lyon for finish compatibility with any chemicals.

NUMBER PLATES Optional aluminum number plates with etched figures at least 3/8" high. All lockers shall have the number plate punching located near top of the doors.

ANCHORING To prevent tipping or injury, Lyon strongly recommends that lockers be floor and/or wall anchored. Z Type Bases are available for lockers without legs.



HEAVY-DUTY CORRIDOR LOCKER FEATURES

- Locker includes door and frame in one of Lyon's premier colors and body parts in Putty
- Door frames are formed by overlapping and welding the junction between the horizontal and vertical members to form a rigid structure that fully frames the door
- Door frames include integral full height 16-gauge door strikes to reinforce door edges
- One piece doors formed from 14-gauge prime, high grade class 1 steel
- Soft rubber bumpers, at door jamb locations, cushion door slams
- Full loop hinges are inserted through slots in the door and frame to maintain alignment and increase strength
- Three latch points on single tier doors and two on double and triple tier doors
- Double tier and triple tier lockers feature an intermediate cross member (ICM) between the doors
- Lockbars feature nano roller latching fingers that engage 12-gauge door jambs for maximum security
- Stainless steel recessed handle is standard on single, double, and triple tier lockers
- Pull handle is standard on lockers 4 tier and higher

CONFIGURATIONS



TIER	FRAME WIDTH	LOCKER DEPTH	NOMINAL DOOR HEIGHT*
Single	12 15 18	12 15 18 21 24	37-1/2 48-5/8 60 72
Double	12 15 18	12 15 18 21 24	30 36
Triple	12 15	12 15 18 21	20 24
Four	12 15	12 15 18 21	15 18
Five	12 15	12 15 18 21	12
Six	12 15	12 15 18 21	10 12

*Add 6" to overall height for legs when included

HANDLES



STAINLESS STEEL RECESSED HANDLE

Standard on single, double and triple-tier lockers with lockbar.

One piece recessed handle pockets add strength to the handle area and eliminate the vulnerable seams of formed handles. The lift handle includes a hasp that can be secured with a user provided padlock.



PULL HANDLE

Standard on multiple tier lockers. A built-in padlock loop easily accepts a user provided padlock.

LEGS



6" HIGH LEGS

Optional 6" high legs provide additional toe room below the locker door. Front legs are a welded piece of the locker frame. Rear legs are adjustable to insure a level installation.

HEAVY-DUTY CORRIDOR

SPECIFICATION SUMMARY

- 14-gauge one piece door
- 16-gauge frame
- 24-gauge body parts
- Full loop type hinges
- Secure multi-point locking system
- Stainless steel recessed handles
- Built-in padlock loop
- Available factory assembled or unassembled

POWDER COAT FINISH

Door and frame shall be painted in one of Lyon's premier color options. Body parts shall be Putty.

Option available to paint body parts to match door and frame.

MATERIAL

Prime, high grade class 1 mild annealed, cold-rolled steel free from surface imperfections. A.S.T.M.-A1008.

Bolts to be zinc plated or subjected to other rust-retardant treatment.

UPGRADES

See pages 34 - 35 for more information on available upgrades such as:

- Alternate Handle Options
- Galvannealed Lockers
- Antimicrobial Paint

CSI formatted specifications available at lyonworkspace.com/architects

Note: There are certain sizes and/or types of lockers that are available in minimum quantity production runs only. Contact your Lyon factory representative for complete details.

BODY 24-gauge steel, flanged to give double thickness of metal at back vertical corners.

DOOR FRAME 16-gauge formed steel channels. Vertical members have an additional flange to form continuous door strike. Corners are lapped and welded into a rigid assembly. In addition, bottom cross members have tang at each end that fits through slot in rear flange of upright frame member to prevent twisting out of alignment. Top and bottom cross members provide support for front edge of locker top and locker bottom.

DOOR One-piece, 14-gauge steel on single, double and triple tier with both vertical edges formed into channel-shaped formation; top and bottom are flanged at a 90 degree angle. Multiple tier lockers have the hinge side formed into channel shaped formation with other three sides flanged at a 90 degree angle.

VENTILATION Louvers shall be provided as follows:

LOCKER STYLE	LOUVERS
Single tier lockers - 12"w and over	Six 6" louvers top and bottom
Double tier lockers - 12"w and over	Six 6" louvers top and bottom
Triple tier lockers - 12"w and over	Two 6" louvers top and bottom
Multiple tier lockers - 12"w and 15"w	Three 3-1/2" louvers centered
Multiple tier lockers - 18"w and over	Four 6" louvers centered

DOOR JAMBS 48" and higher single tier lockers have three door jambs; double tier and triple tier lockers have two jambs welded to side of door frames to engage locking device. Design and gauge of jamb prevent freeing of locking device by prying. Each jamb has easily replaceable soft rubber bumpers.

HINGES shall not be less than 2" high, 18-gauge steel, 5 knuckle, full loop design forming double thickness on each leaf. Hinges are set in slot in door and frame and projection welded to frame and securely riveted to door. Hinge pins are spun over at ends to resist removal. Single-tier lockers 48", 60" and 72" high have three hinges. All other tiers have two hinges - all on right hand side of door. *Optional continuous hinge riveted to frame in lieu of knuckle hinges available.

QUIET LOCKING DEVICE The single tier locking device engages the frame at three points; double tier and triple tier at two points. The channel shaped locking device with full length reinforcing ribs are a quiet design utilizing nylon guide inserts to reduce metal to metal contact. The locking device includes a latch finger that engages the 12-gauge door jamb. The lockbar is enclosed on three sides and operate within the channel formation of the door. The locking device is pre-locking so mechanism can be locked in open position - door locking automatically when closed. An optional single point latch is available except on 9" wide lockers. Box lockers have one-point locking device with a 14-gauge lock clip for attaching padlock. Doors also provide a lock hole filler to permit use of built-in lock.

HANDLES On single, double and triple tier lockers, handles are stainless steel recessed. No moving parts are to operate against outside surface of locker. Padlock attachment is an integral part of lift which is attached directly to locking bar and protected by fixed handle housing. Handle provides a built-in padlock strike. The recessed handle is 4-1/8"w x 6-1/16"h x 1-1/4"d. Multiple tier lockers are equipped with a 16-gauge door pull with padlock attachment when not used with built-in locks.

SHELVES Single tier lockers have one 24-gauge shelf approximately 9" below top. Flanged on all four sides for strength with the front flange turned 45 degrees for safety and attached at no less than two points through each side flange. Only single tier lockers 48" and taller have shelves.

COAT HOOKS Single tier, double tier and triple tier lockers have one double prong hook and three single prong wall hooks. 5/8" diameter coat rods are standard in 18" and 21" deep knocked down single tier lockers, replacing ceiling hook. All hooks are zinc plated or subjected to a comparable rust retardant treatment and attached with two nuts and bolts.

STANDARD FINISH Exposed steel parts are thoroughly cleaned, given a bonding and rust inhibitive phosphate treatment and then electrostatically sprayed with powder coat. NOTE: contact Lyon for finish compatibility with any chemicals.

NUMBER PLATES Optional aluminum number plates with etched figures at least 3/8" high. All lockers shall have the number plate punching located near top of the doors.

ANCHORING To prevent tipping or injury, Lyon strongly recommends that lockers be floor and/or wall anchored. Z Type Bases are available for lockers without legs.



HEAVY-DUTY LOCKER FEATURES

- Locker includes door and frame in one of Lyon's premier colors and body parts in Putty
- Door frames are formed by overlapping and welding the junction between the horizontal and vertical members to form a rigid structure that fully frames the door
- Door frames include integral full height 16-gauge door strikes to reinforce door edges
- One piece doors formed from 14-gauge prime, high grade class 1 steel
- Soft rubber bumpers, at door jamb locations, cushion door slams
- Full loop hinges are inserted through slots in the door and frame to maintain alignment and increase strength
- Three latch points on single tier doors and two on double and triple tier doors
- Double tier and triple tier lockers feature an intermediate cross member (ICM) between the doors
- Lockbars feature nano roller latching fingers that engage 12-gauge door jambs for maximum security
- Stainless steel recessed handle is standard on single, double, and triple tier lockers
- Pull handle is standard on lockers 4 tier and higher

CONFIGURATIONS



TIER	FRAME WIDTH	LOCKER DEPTH	NOMINAL DOOR HEIGHT*
Single	12 15 18	12 15 18 21 24	37-1/2 48-5/8 60 72
Double	12 15 18	12 15 18 21 24	30 36
Triple	12 15	12 15 18 21	20 24
Four	12 15	12 15 18 21	15 18
Five	12 15	12 15 18 21	12
Six	12 15	12 15 18 21	10 12

*Add 6" to overall height for legs when included

HANDLES



STAINLESS STEEL RECESSED HANDLE

Standard on single, double and triple-tier lockers with lockbar.

One piece recessed handle pockets add strength to the handle area and eliminate the vulnerable seams of formed handles. The lift handle includes a hasp that can be secured with a user provided padlock.



PULL HANDLE

Standard on multiple tier lockers. A built-in padlock loop easily accepts a user provided padlock.

LEGS



6" HIGH LEGS

Optional 6" high legs provide additional toe room below the locker door. Front legs are a welded piece of the locker frame. Rear legs are adjustable to insure a level installation.

HEAVY-DUTY

SPECIFICATION SUMMARY

- 14-gauge one piece door
- 16-gauge frame
- 16-gauge body parts / 18-gauge backs
- Full loop type hinges
- Secure multi-point locking system
- Stainless steel recessed handles
- Built-in padlock loop
- Available factory assembled or unassembled

POWDER COAT FINISH

Door and frame shall be painted in one of Lyon's premier color options. Body parts shall be Putty.

Option available to paint body parts to match door and frame.

MATERIAL

Prime, high grade class 1 mild annealed, cold-rolled steel free from surface imperfections. A.S.T.M.-A1008.

Bolts to be zinc plated or subjected to other rust-retardant treatment.

UPGRADES

See pages 34 - 35 for more information on available upgrades such as:

- Alternate Handle Options
- Galvannealed Lockers
- Antimicrobial Paint

CSI formatted specifications available at lyonworkspace.com/architects

Note: There are certain sizes and/or types of lockers that are available in minimum quantity production runs only. Contact your Lyon factory representative for complete details.

BODY 16-gauge steel, flanged to give double thickness of metal at back vertical corners, 18-gauge backs

DOOR FRAME 16-gauge formed steel channels. Vertical members have an additional flange to form continuous door strike. Corners are lapped and welded into a rigid assembly. In addition, bottom cross members have tang at each end that fits through slot in rear flange of upright frame member to prevent twisting out of alignment. Top and bottom cross members provide support for front edge of locker top and locker bottom.

DOOR One-piece, 14-gauge steel on single, double and triple tier with both vertical edges formed into channel-shaped formation; top and bottom are flanged at a 90 degree angle. On multiple tier lockers the hinge side is formed into channel shaped formation with other three sides flanged at a 90 degree angle.

VENTILATION Louvers shall be provided as follows:

LOCKER STYLE	LOUVERS
Single tier lockers - 12"w and over	Six 6" louvers top and bottom
Double tier lockers - 12"w and over	Six 6" louvers top and bottom
Triple tier lockers - 12"w and over	Two 6" louvers top and bottom
Multiple tier lockers - 12"w and 15"w	Three 3-1/2" louvers centered
Multiple tier lockers - 18"w and over	Four 6" louvers centered

DOOR JAMBS 48" and higher single tier lockers have three door jambs; double tier and triple tier lockers have two jambs welded to side of door frames to engage locking device. Design and gauge of jamb prevent freeing of locking device by prying. Each jamb has easily replaceable soft rubber bumpers.

HINGES shall not be less than 2" high, 18-gauge steel, 5 knuckle, full loop design forming double thickness on each leaf. Hinges are set in slot in door and frame and projection welded to frame and securely riveted to door. Hinge pins are spun over at ends to resist removal. Single-tier lockers 48", 60" and 72" high have three hinges. All other tiers have two hinges - all on right hand side of door. *Optional continuous hinge riveted to frame in lieu of knuckle hinges available.

QUIET LOCKING DEVICE The single tier locking device engages the frame at three points; double tier and triple tier at two points. The channel shaped locking device with full length reinforcing ribs are a quiet design utilizing nylon guide inserts to reduce metal to metal contact. The locking device includes a latch finger that engages the 12-gauge door jamb. The lockbar is enclosed on three sides and operate within the channel formation of the door. The locking device is pre-locking so mechanism can be locked in open position - door locking automatically when closed. An optional single point latch is available except on 9" wide lockers. Box lockers have one-point locking device with a 14-gauge lock clip for attaching padlock. Doors also provide a lock hole filler to permit use of built-in lock.

HANDLES On single, double and triple tier lockers, handles are stainless steel recessed. No moving parts are to operate against outside surface of locker. Padlock attachment is an integral part of lift which is attached directly to locking bar and protected by fixed handle housing. Handle provides a built-in padlock strike. The recessed handle is 4-1/8"w x 6-1/16"h x 1-1/4"d. Multiple tier lockers are equipped with a 16-gauge door pull with padlock attachment when not used with built-in locks.

SHELVES Single tier lockers have one 16-gauge shelf approximately 9" below top. Flanged on all four sides for strength with the front flange turned 45 degrees for safety and attached at no less than two points through each side flange. Only single tier lockers 48" and taller have shelves.

COAT HOOKS Single tier, double tier and triple tier lockers have one double prong hook and three single prong wall hooks. 5/8" diameter coat rods are standard in 18" and 21" deep knocked down single tier lockers, replacing ceiling hook. All hooks are zinc plated or subjected to a comparable rust retardant treatment and attached with two nuts and bolts.

STANDARD FINISH Exposed steel parts are thoroughly cleaned, given a bonding and rust inhibitive phosphate treatment and then electrostatically sprayed with powder coat.

NOTE: contact Lyon for finish compatibility with any chemicals.

NUMBER PLATES Optional aluminum number plates with etched figures at least 3/8" high. All lockers shall have the number plate punching located near top of the doors.

ANCHORING To prevent tipping or injury, Lyon strongly recommends that lockers be floor and/or wall anchored. Z Type Bases are available for lockers without legs.



HEAVY-DUTY VENTILATED LOCKER FEATURES

- Locker includes door, frame and body parts in one of Lyon's premier colors
- Door frames are formed by overlapping and welding the junction between the horizontal and vertical members to form a rigid structure that fully frames the door
- Door frames include integral full height 16-gauge door strikes to reinforce door edges
- One piece doors formed from 14-gauge prime, high grade class 1 steel
- Soft rubber bumpers, at door jamb locations, cushion door slams
- Full loop hinges are inserted through slots in the door and frame to maintain alignment and increase strength
- Three latch points on single tier doors and two on double and triple tier doors
- Double tier and triple tier lockers feature an intermediate cross member (ICM) between the doors
- Lockbars feature nano roller latching fingers that engage 12-gauge door jambs for maximum security
- Stainless steel recessed handle is standard on single, double, and triple tier lockers
- Pull handle is standard on lockers 4 tier and higher

CONFIGURATIONS



TIER	FRAME WIDTH	LOCKER DEPTH	NOMINAL DOOR HEIGHT*
Single	12 15 18	12 15 18 21 24	37-1/2 48-5/8 60 72
Double	12 15 18	12 15 18 21 24	30 36
Triple	12 15	12 15 18 21	20 24
Four	12 15	12 15 18 21	15 18
Five	12 15	12 15 18 21	12
Six	12 15	12 15 18 21	10 12

*Add 6" to overall height for legs when included

HANDLES



STAINLESS STEEL RECESSED HANDLE

Standard on single, double and triple-tier lockers with lockbar.

One piece recessed handle pockets add strength to the handle area and eliminate the vulnerable seams of formed handles. The lift handle includes a hasp that can be secured with a user provided padlock.



PULL HANDLE

Standard on multiple tier lockers. A built-in padlock loop easily accepts a user provided padlock.

LEGS



6" HIGH LEGS

Optional 6" high legs provide additional toe room below the locker door. Front legs are a welded piece of the locker frame. Rear legs are adjustable to insure a level installation.

BODY 16-gauge steel, flanged to give double thickness of metal at back vertical corners, 18-gauge backs

DOOR FRAME 16-gauge formed steel channels. Vertical members have an additional flange to form continuous door strike. Corners are lapped and welded into a rigid assembly. In addition, bottom cross members have tang at each end that fits through slot in rear flange of upright frame member to prevent twisting out of alignment. Top and bottom cross members provide support for front edge of locker top and locker bottom.

DOOR One-piece, 14-gauge steel on single, double and triple tier with both vertical edges formed into channel-shaped formation; top and bottom are flanged at a 90 degree angle. On multiple tier lockers the hinge side is formed into channel shaped formation with other three sides flanged at a 90 degree angle.

VENTILATION Sides and door shall be punched with diamond shaped perforations. Optional solid sides available.

DOOR JAMBS 48" and higher single tier lockers have three door jambs; double tier and triple tier lockers have two jambs welded to side of door frames to engage locking device. Design and gauge of jamb prevent freeing of locking device by prying. Each jamb has easily replaceable soft rubber bumpers.

HINGES shall not be less than 2" high, 18-gauge steel, 5 knuckle, full loop design forming double thickness on each leaf. Hinges are set in slot in door and frame and projection welded to frame and securely riveted to door. Hinge pins are spun over at ends to resist removal. Single-tier lockers 48", 60" and 72" high have three hinges. All other tiers have two hinges – all on right hand side of door.

*Optional continuous hinge riveted to frame in lieu of knuckle hinges available.

QUIET LOCKING DEVICE The single tier locking device engages the frame at three points; double tier and triple tier at two points. The channel shaped locking device with full length reinforcing ribs are a quiet design utilizing nylon guide inserts to reduce metal to metal contact. The locking device includes a latch finger that engages the 12-gauge door jamb. The lockbar is enclosed on three sides and operate within the channel formation of the door. The locking device is pre-locking so mechanism can be locked in open position – door locking automatically when closed. An optional single point latch is available except on 9" wide lockers. Box lockers have one-point locking device with a 14-gauge lock clip for attaching padlock. Doors also provide a lock hole filler to permit use of built-in lock.

HANDLES On single, double and triple tier lockers, handles are stainless steel recessed. No moving parts are to operate against outside surface of locker. Padlock attachment is an integral part of lift which is attached directly to locking bar and protected by fixed handle housing. Handle provides a built-in padlock strike. The recessed handle is 4-1/8" w x 6-1/16" h x 1-1/4" d. Multiple tier lockers are equipped with a 16-gauge door pull with padlock attachment when not used with built-in locks.

SHELVES Single tier lockers have one 16-gauge shelf approximately 9" below top. Flanged on all four sides for strength with the front flange turned 45 degrees for safety and attached at no less than two points through each side flange. Only single tier lockers 48" and taller have shelves.

COAT HOOKS Single tier, double tier and triple tier lockers have one double prong hook and three single prong wall hooks. 5/8" diameter coat rods are standard in 18" and 21" deep knocked down single tier lockers, replacing ceiling hook. All hooks are zinc plated or subjected to a comparable rust retardant treatment and attached with two nuts and bolts.

STANDARD FINISH Exposed steel parts are thoroughly cleaned, given a bonding and rust inhibitive phosphate treatment and then electrostatically sprayed with powder coat. NOTE: contact Lyon for finish compatibility with any chemicals.

NUMBER PLATES Optional aluminum number plates with etched figures at least 3/8" high. All lockers shall have the number plate punching located near top of the doors.

ANCHORING To prevent tipping or injury, Lyon strongly recommends that lockers be floor and/or wall anchored. Z Type Bases are available for lockers without legs.

HEAVY-DUTY VENTILATED

SPECIFICATION SUMMARY

- 14-gauge one piece door
- 16-gauge frame
- 16-gauge body parts / 18-gauge backs
- Full loop type hinges
- Diamond perforations on doors & sides
- Secure multi-point locking system
- Stainless steel recessed handles
- Built-in padlock loop
- Available factory assembled or unassembled

POWDER COAT FINISH

Door, frame, and body parts shall be painted in one of Lyon's premier color options.

MATERIAL

Prime, high grade class 1 mild annealed, cold-rolled steel free from surface imperfections. A.S.T.M.-A1008.

Bolts to be zinc plated or subjected to other rust-retardant treatment.

UPGRADES

See pages 34 - 35 for more information on available upgrades such as:

- Alternate Handle Options
- Galvannealed Lockers
- Antimicrobial Paint

CSI formatted specifications available at lyonworkspace.com/architects

Note: There are certain sizes and/or types of lockers that are available in minimum quantity production runs only. Contact your Lyon factory representative for complete details.



ALL-WELDED LOCKER FEATURES

- Locker includes door and frame in one of Lyon's premier colors
- Door frames are formed by overlapping and welding the junction between the horizontal and vertical members to form a rigid structure that fully frames the door
- Door frames include integral full height 16-gauge door strikes to reinforce door edges
- One piece doors formed from 14-gauge prime, high grade class 1 steel
- Soft rubber bumpers, at door jamb locations, cushion door slams
- Full loop hinges are inserted through slots in the door and frame to maintain alignment and increase strength
- Three latch points on single tier doors and two on double and triple tier doors
- Double tier and triple tier lockers feature an intermediate cross member (ICM) between the doors
- Lockbars feature nano roller latching fingers that engage 12-gauge door jambs for maximum security
- Stainless steel recessed handle is standard on single, double, and triple tier lockers
- Pull handle is standard on lockers 4 tier and higher

CONFIGURATIONS



TIER	FRAME WIDTH	LOCKER DEPTH	NOMINAL DOOR HEIGHT*
Single	12 15 18	12 15 18 21 24	37-1/2 48-5/8 60 72
Double	12 15 18	12 15 18 21 24	30 36
Triple	12 15	12 15 18 21	20 24
Four	12 15	12 15 18 21	15 18
Five	12 15	12 15 18 21	12
Six	12 15	12 15 18 21	10 12

*Add 6" to overall height for legs when included

HANDLES



STAINLESS STEEL RECESSED HANDLE

Standard on single, double and triple-tier lockers with lockbar.

One piece recessed handle pockets add strength to the handle area and eliminate the vulnerable seams of formed handles. The lift handle includes a hasp that can be secured with a user provide padlock.



PULL HANDLE

Standard on multiple tier lockers. A built-in padlock loop easily accepts a user provided padlock.

LEGS



6" HIGH LEGS

Optional 6" high legs provide additional toe room below the locker door. Front legs are a welded piece of the locker frame. Rear legs are adjustable to insure a level installation.

BODY 16-gauge steel, flanged to give double thickness of metal at back vertical corners. 18-gauge backs.

DOOR FRAME 16-gauge formed steel channels. Vertical members shall have an additional flange to form continuous door strike. Corners shall be lapped and welded into a rigid assembly. In addition, bottom cross members shall have tang at each end that fits through slot in rear flange of upright frame member to prevent twisting out of alignment. Top and bottom cross members shall provide support for front edge of locker top and locker bottom.

DOOR One-piece, 14-gauge steel on single, double and triple tier with both vertical edges formed into channel-shaped formation; top and bottom shall be flanged at 90 degree angle. On multiple tier lockers the hinge side shall be formed into channel shaped formation with other three sides flanged at a 90 degree angle.

VENTILATION Louvers shall be provided as follows:

LOCKER STYLE	LOUVERS
Single tier lockers - 12"w and over	Six 6" louvers top and bottom
Double tier lockers - 12"w and over	Six 6" louvers top and bottom
Triple tier lockers - 12"w and over	Two 6" louvers top and bottom
Multiple tier lockers - 12"w and 15"w	Three 3-1/2" louvers centered
Multiple tier lockers - 18"w and over	Four 6" louvers centered

DOOR JAMBS 48" and higher single tier lockers shall have three door jambs; double tier and triple tier lockers shall have two jambs welded to side of door frames to engage locking device. Design and gauge of jamb shall prevent freeing of locking device by prying. Each jamb shall have easily replaceable soft rubber bumper.

HINGES shall not be less than 2" high, 18-gauge steel, 5 knuckle, full loop design forming double thickness on each leaf. Hinges are set in slot in door and frame and projection welded to frame and securely riveted to door. Hinge pins are spun over at ends to resist removal. Single-tier lockers 48", 60" and 72" high have three hinges. All other tiers have two hinges - all on right hand side of door.

*Optional continuous hinge riveted to frame in lieu of knuckle hinges available.

QUIET LOCKING DEVICE Single tier locking device shall engage frame at three points; double tier and triple tier at two points. The channel shaped locking device with full length reinforcing ribs shall be a quiet design utilizing nylon guide inserts to reduce metal to metal contact. The locking device shall include a latch finger that engages the 12-gauge door jamb. Lock bar shall be enclosed on three sides and operate within the channel formation of the door. Locking device shall be pre-locking so mechanism can be locked in open position - door locking automatically when closed. An optional single point latch shall be available except on 9" wide lockers. Box locker shall have one-point locking device with a 14-gauge lock clip for attaching padlock. Doors also to be provided with lock hole filler to permit use of built-in lock.

HANDLES On single, double and triple tier lockers, handles are stainless steel recessed. No moving parts are to operate against outside surface of locker. Padlock attachment is an integral part of lift which is attached directly to locking bar and protected by fixed handle housing. Handle provides a built-in padlock strike. The recessed handle is 4-1/8"w x 6-1/16"h x 1-1/4"d. Multiple tier lockers are equipped with a 16-gauge door pull with padlock attachment when not used with built-in locks.

SHELVES Single tier lockers shall have one 16-gauge shelf approximately 9" below top. Flanged on all four sides for strength with the front flange turned 45 degrees for safety and attached at no less than two points through each side flange. Only single tier lockers 48" and taller have shelves.

COAT HOOKS Single tier, double tier and triple tier lockers shall have one double prong hook and three single prong wall hooks. All hooks to be zinc-plated or subjected to a comparable rust retardant treatment and attached with two nuts and bolts. Hooks will be installed and painted to match locker.

STANDARD FINISH Exposed steel parts shall be thoroughly cleaned, given a bonding and rust inhibitive phosphate treatment and then electrostatically sprayed with powder coat.

NOTE: Contact Lyon for finish compatibility with any chemicals.

NUMBER PLATES Optional aluminum number plates with etched figures at least 3/8" high. All lockers shall have the number plate punching located at the near top of the doors.

ANCHORING To prevent tipping or injury, Lyon strongly recommends that lockers be floor and/or wall anchored. Z Type Bases are available for lockers without legs.

ALL-WELDED

SPECIFICATION SUMMARY

- 14-gauge one piece door
- 16-gauge frame
- 16-gauge body parts / 18-gauge backs
- Full loop type hinges
- Secure multi-point locking system
- Stainless steel recessed handles
- Built-in padlock loop
- Assembled - all seams & joints welded

POWDER COAT FINISH

Door, frame, and body parts shall be painted in one of Lyon's premier color options.

MATERIAL

Prime, high grade class 1 mild annealed, cold-rolled steel free from surface imperfections. A.S.T.M.-A1008.

Bolts to be zinc plated or subjected to other rust-retardant treatment.

UPGRADES

See pages 34 - 35 for more information on available upgrades such as:

- Alternate Handle Options
- Galvannealed Lockers
- Antimicrobial Paint

CSI formatted specifications available at lyonworkspace.com/architects

Note: There are certain sizes and/or types of lockers that are available in minimum quantity production runs only. Contact your Lyon factory representative for complete details.



ALL-WELDED EXTREME LOCKER FEATURES

- Locker includes door and frame in one of Lyon's premier colors
- Door frames are formed by overlapping and welding the junction between the horizontal and vertical members to form a rigid structure that fully frames the door
- Door frames include integral full height 16-gauge door strikes to reinforce door edges
- One piece doors formed from 16-gauge prime, high grade class 1 steel
- Soft rubber bumpers, at door jamb locations, cushion door slams
- Full height continuous hinges
- Three latch points on single tier doors and two on double and triple tier doors
- Double tier and triple tier lockers feature an intermediate cross member (ICM) between the doors
- Lockbars feature nano roller latching fingers that engage 12-gauge door jambs for maximum security
- Stainless steel recessed handle is standard on single, double, and triple tier lockers
- Pull handle is standard on lockers 4 tier and higher

HANDLES



STAINLESS STEEL RECESSED HANDLE

Standard on single, double and triple-tier lockers with lockbar.

One piece recessed handle pockets add strength to the handle area and eliminate the vulnerable seams of formed handles. The lift handle includes a hasp that can be secured with a user provide padlock.



PULL HANDLE

Standard on multiple tier lockers. A built-in padlock loop easily accepts a user provided padlock.

LEGS



6" HIGH LEGS

Optional 6" high legs provide additional toe room below the locker door. Front legs are a welded piece of the locker frame. Rear legs are adjustable to insure a level installation.

CONFIGURATIONS



TIER	FRAME WIDTH	LOCKER DEPTH	NOMINAL DOOR HEIGHT*
Single	12 15 18	12 15 18 21 24	37-1/2 48-5/8 60 72
Double	12 15 18	12 15 18 21 24	30 36
Triple	12 15	12 15 18 21	20 24
Four	12 15	12 15 18 21	15 18
Five	12 15	12 15 18 21	12
Six	12 15	12 15 18 21	10 12

*Add 6" to overall height for legs when included

ALL-WELDED EXTREME

SPECIFICATION SUMMARY

- 14-gauge one piece door
- 18-gauge pan reinforcement on door
- 16-gauge frame
- 16-gauge body parts / 18-gauge backs
- 16-gauge reinforced bottom channels
- Continuous hinges
- Secure multi-point locking system
- Stainless steel recessed handles
- Built-in padlock loop
- Assembled - all seams & joints welded

POWDER COAT FINISH

Door, frame, and body parts shall be painted in one of Lyon's premier color options.

MATERIAL

Prime, high grade class 1 mild annealed, cold-rolled steel free from surface imperfections. A.S.T.M.-A1008.

Bolts to be zinc plated or subjected to other rust-retardant treatment.

UPGRADES

See pages 34 - 35 for more information on available upgrades such as:

- Alternate Handle Options
- Galvannealed Lockers
- Antimicrobial Paint

CSI formatted specifications available at lyonworkspace.com/architects

Note: There are certain sizes and/or types of lockers that are available in minimum quantity production runs only. Contact your Lyon factory representative for complete details.

BODY 16-gauge steel, flanged to give double thickness of metal at back vertical corners. 18-gauge backs. Bottoms shall have a 16-gauge channel reinforcement from front to back.

DOOR FRAME 16-gauge formed steel channels. Vertical members shall have an additional flange to form continuous door strike. Corners shall be lapped and welded into a rigid assembly. In addition, bottom cross members shall have tang at each end that fits through slot in rear flange of upright frame member to prevent twisting out of alignment. Top and bottom cross members shall provide support for front edge of locker top and locker bottom.

DOOR One-piece, 14-gauge steel on single, double and triple tier with both vertical edges formed into channel-shaped formation; top and bottom shall be flanged at 90 degree angle. On multiple tier lockers the hinge side shall be formed into channel shaped formation with other three sides flanged at a 90 degree angle. An 18-gauge pan stiffener will be welded inside the channel - shaped formation of the hinge side of the door. Stiffeners shall be 1" wide on 12" wide doors, 3-1/2" wide on 15" and 18" wide doors, and 7-1/2" wide on 24" wide doors.

VENTILATION Louvers shall be provided as follows:

LOCKER STYLE	LOUVERS
Single tier lockers - 12"w and over	Six 6" louvers top and bottom
Double tier lockers - 12"w and over	Six 6" louvers top and bottom
Triple tier lockers - 12"w and over	Two 6" louvers top and bottom
Multiple tier lockers - 12"w and 15"w	Three 3-1/2" louvers centered
Multiple tier lockers - 18"w and over	Four 6" louvers centered

DOOR JAMBS 48" and higher single tier lockers shall have three door jambs; double tier and triple tier lockers shall have two jambs welded to side of door frames to engage locking device. Design and gauge of jamb shall prevent freeing of locking device by prying. Each jamb shall have easily replaceable soft rubber bumper.

HINGES Shall be full height continuous.

QUIET LOCKING DEVICE Single tier locking device shall engage frame at three points; double tier and triple tier at two points. The channel shaped locking device with full length reinforcing ribs shall be a quiet design utilizing nylon guide inserts to reduce metal to metal contact. The locking device shall include a latch finger that engages the 12-gauge door jamb. Lock bar shall be enclosed on three sides and operate within the channel formation of the door. Locking device shall be pre-locking so mechanism can be locked in open position - door locking automatically when closed. An optional single point latch shall be available except on 9" wide lockers. Box locker shall have one-point locking device with a 14-gauge lock clip for attaching padlock. Doors also to be provided with lock hole filler to permit use of built-in lock.

HANDLES On single, double and triple tier lockers, handles shall be stainless steel recessed. No moving parts are to operate against outside surface of locker. Padlock attachment to be integral part of lift which shall be attached directly to locking bar and protected by fixed handle housing. Handle to provide built-in padlock strike. The recessed handle shall be 4-1/8"w x 6-1/16"h x 1-1/4"d. Multiple tier lockers shall be equipped with a 16-gauge door pull with padlock attachment when not used with built-in locks. Die Cast Recessed and chrome turn handle options available.

SHELVES Single tier lockers shall have one 16-gauge shelf approximately 9" below top. Flanged on all four sides for strength with the front flange turned 45 degrees for safety and attached at no less than two points through each side flange. Only single tier lockers 48" and taller have shelves.

COAT HOOKS Single tier, double tier and triple tier lockers shall have one double prong hook and three single prong wall hooks. All hooks to be zinc-plated or subjected to a comparable rust retardant treatment and attached with two nuts and bolts. Hooks will be installed and painted to match locker.

STANDARD FINISH Exposed steel parts shall be thoroughly cleaned, given a bonding and rust inhibitive phosphate treatment and then electrostatically sprayed with powder coat. NOTE: Contact Lyon for finish compatibility with any chemicals.

NUMBER PLATES Optional aluminum number plates with etched figures at least 3/8" high. All lockers shall have number plates attached near top of door.

ANCHORING To prevent tipping or injury, Lyon strongly recommends that lockers be floor and/or wall anchored. Z Type Bases are available for lockers without legs.



VICTORY LOCKER FEATURES

- Locker includes choice of one of Lyon's premier colors
- Constructed of 16-gauge steel with 1-gauge steel back
- Diamond perforated sides and solid back
- Full width 18-gauge upper shelf with 2" h steel name plate
- Coat rod with four double prong hooks
- Full width 14-gauge lower shelf
- Building block design to create the perfect locker

OPTIONAL UPGRADE



TWO-TONE COLOR

Perfect for team locker rooms! Show off your team's colors by choosing a second accent color for the small compartment door and front of the footlocker.

OPTIONAL COMPONENTS



SMALL COMPARTMENT

Easily secure personal items in the small upper compartment. This compartment offers a clear opening of 8-1/2" wide.

The door includes a steel pull handle on the door. Easily add your own padlock or a built-in combination lock to secure the door closed.



FOOTLOCKER

The footlocker extends 9-1/2" past the main locker frame creating an easy seat for a fully uniformed player.

A full width piano hinge helps the lid lift smoothly to allow bulky items to be stored inside. The lid includes a hasp allowing you to easily add your own padlock to secure the items inside.

CONFIGURATIONS



LOCKER	WIDTH	DEPTH	HEIGHT
Basic / Small Compartment	24 28	15	72
Deluxe / Footlocker	24 28	24 -1/2	72
COMPONENTS	WIDTH	DEPTH	HEIGHT
Small Compartment	8-1/2	15	12
Footlocker	24 28	9-1/2	18

BODY All tops, bottoms, sides, side extensions, upper shelf, upper shelf reinforcement and lower compartment bottom extensions will all be 16-gauge steel. Lower shelf will be 14-gauge steel. Backs are manufactured using 18-gauge steel.

DOOR This is an open front locker and a full length locker door is not available.

VENTILATION Sides shall be punched with diamond shaped perforations.

UPPER SHELF Lockers shall have one 16-gauge shelf approximately 12" clear below top. Flanged on all four sides for strength with the front flange with a 90 degree return flange attached at no less than two points through each side flange. Shelf includes a 2-1/2" x 15/16" C-Channel reinforcement running the full width of shelf and constructed of 16-gauge steel. Upper shelf is punched for name plate holder.

LOWER SHELF Lockers shall have one 14-gauge shelf approximately 18" from bottom.

HOOKS Each locker will include four double prong wall hooks made with 3/16" diameter cold drawn wire with ball ends. NOTE: Hooks on all-welded lockers will be installed and painted to match locker.

COAT RODS Each locker will include one 1" diameter 18-gauge coat rod. Brackets are 16-gauge and screwed to the shelf reinforcement. NOTE: All-welded options will have hooks in lieu of coat rod.

NAME PLATE HOLDER 2" Name Plate Holder is manufactured using 22-gauge stainless steel and is attached to the upper shelf using standard nuts/bolt or pop rivets.

STANDARD FINISH Exposed steel parts shall be thoroughly cleaned, given a bonding and rust inhibitive phosphate treatment and then electrostatically sprayed with a powder coat. NOTE: Contact Lyon for finish compatibility with any chemicals.

ANCHORING To prevent tipping or injury, Lyon strongly recommends that lockers be floor and/or wall anchored.

OPTIONAL FOOTLOCKER Lower storage compartment is designed to allow for bulk storage and lock-up capability. Bulk compartment lid acts as a seating area as well. Footlocker is 18" in height, full depth of 24-1/2" and consists of the following components:

Bin front assembly made of 14-gauge steel

Lid assembly made of 14-gauge steel and connected to an 18-gauge continuous hinge. Lower gussets at the upper front corners of the lower compartment are 12-gauge. Hasp located on the underside of the lid is 11-gauge. Hasp allows for locking capability with use of padlocks. A 24-gauge stainless steel padlock strike is included.

OPTIONAL UPPER STORAGE COMPARTMENT Designed to allow for small compartment storage with lockup capabilities. Storage Compartment is 12" in height, 9" in width, and is 15" deep. The upper storage compartment consists of the following components:

Right side is constructed utilizing the locker side panel made of 16-gauge steel.

Left hand side and lock member are made of 16-gauge steel with formations that make up the left side of the box and includes a pull handle that accepts either padlock or built-in combination lock to secure the door closed.

18-gauge right hand hinged door formed with flanges on three sides. Door is equipped with punching to allow for built-in locks.

OPTIONAL ACCESSORIES



PADDED BENCH SEAT

Increase the comfort of your players by adding a padded seat. The thick padded cushion is wrapped in a durable easy-to-clean vinyl. The vinyl wrap can be personalized with your team colors or logo.



HARDWOOD BENCH SEAT

Add a durable wooden bench top made of multiple hardwoods and finished with two coats of clear acrylic. The acrylic finish gives the wood top a glossy look. It also forms a hard resin to help protect the bench top from scratches from every day use.

VICTORY

SPECIFICATION SUMMARY

- Open style locker
- 16-gauge locker / 18-gauge backs
- 16-gauge upper shelf / 14-gauge lower shelf
- Diamond perforations on sides
- Steel Name Plate Holder
- Available factory assembled, unassembled, or all-welded

OPTIONAL

- Upper Storage Compartment
- Footlocker
- Two-Tone Finish

POWDER COAT FINISH

Frame and body parts shall be painted in one of Lyon's premier color options.

MATERIAL

Prime, high grade class 1 mild annealed, cold-rolled steel free from surface imperfections. A.S.T.M.-A1008.

Bolts to be zinc plated or subjected to other rust-retardant treatment.

UPGRADES

See page 35 for more information on available upgrades such as:

- Antimicrobial Paint

Note: There are certain sizes and/or types of lockers that are available in minimum quantity production runs only. Contact your Lyon factory representative for complete details.



VALOR FEATURES

The **All-Welded** upper shell of the Valor Locker is constructed of 16-gauge steel with an 18-gauge back. The **Perforated Top** provides ventilation for the unit to allow for airflow throughout the locker and keep contents cool and dry.

An **Electrical Feed Portal** in the top rear corner provides the option for adding electric capabilities within each locker. Easily add power or USB outlets to charge cell phones or laptops.

The one-piece 14-gauge steel door features a pan reinforcement for extra security. The standard **Recessed Handle** includes a lift handle with a hasp that can be secured with a padlock or built-in lock.

A **Boot Drawer Latch** inside the locker provides quick, easy access to the boot drawer. An auto locking capability engages when the lower drawer is closed, instantly securing the items inside.

The **Lower Drawer Unit** provides ample storage for boots, duffle bags, and other large gear. When closed it doubles as a built-in seat.

The **Overall Height** of the upper shell and lower drawer unit together is 90" high.



VALOR ACCESSORIES

A variety of accessories can help compartmentalize the upper shell to help maximize storage and security.

The **Partition Kit** includes a ventilated partition and a shelf for storing hats or briefcases. The included coat rod and hooks offer ample space for hanging uniforms, coats and civilian clothes.

Belt Clips attached to the door offer easy storage for hanging a variety of belts and holsters. The door **Mirror** with magnetic backing can be positioned right where it is needed.

Add the small **Security Compartment** for storing small personal items. This door includes a pull handle that can be secured with a padlock or built-in lock.

Mount this compartment directly under the full shelf, or add the **Compartment Shelf** on top to create even more storage cubbies.

Add another **Compartment Shelf** with a **Double Prong Hook** to add more hanging storage.

The perforated **Boot Tray** is removable for the ease of use and cleaning.

A **Hardwood Bench** on top of the lower drawer unit offers a convenient place to sit when removing shoes, boots, or gear.

A **Vest Shelf** is available for both the upper shell and the lower drawer unit. These shelves have extra perforations to provide plenty of ventilation for Kevlar vest storage.

VALOR LOCKER ORDERING GUIDE

Easily customize interior components to create the perfect Valor Locker for your facility. Lockers are offered in 18" or 24" wide units. Determine the width needed for your locker and choose the matching accessories.

18" WIDE VALOR	24" WIDE VALOR
----------------	----------------

STEP 1

Select Upper Unit Shell

ITEM No.	DIMENSIONS	ITEM	DIMENSIONS	ITEM No.
1 VL5104	18"w x 24"d x 72"h	Upper Unit Shell	24"w x 24"d x 72"h	VL5578

STEP 2 - Option A WITHOUT Partition

Select Accessories to use WITHOUT Partition

ITEM No.	DIMENSIONS	ITEM	DIMENSIONS	ITEM No.
VL184SS	18"w	Full Width Shelf	24"w	VL24SS
VL184VS	18"w	Full Width Vest Shelf	24"w	VL24VS
VL081211	8"w x 12"d x 11"h	Stand Alone Security Compartment *	8"w x 12"d x 11"h	VL081211
VL122411	12"w x 20-5/8"d x 11"h	Stand Alone Security Compartment *	12"w x 20-5/8"d x 11"h	VL122411

STEP 2 - Option B WITH Partition

Select Partition Kit and Accessories

Partition kit includes partition, full width shelf, two utility hooks, and coat rod

ITEM No.	DIMENSIONS	ITEM	DIMENSIONS	ITEM No.
VL1858PT	18"w x 24"d	Upper Unit Partition Kit	24"w x 24"d	VL2458PT
2 VL184SS	18"w	Full Width Shelf †	24"w	VL24SS
3 VL184VS	18"w	Full Width Vest Shelf †	24"w	VL24VS
4 VL0808LU	8"w x 8"h	Security Compartment Door Kit ‡	8"w x 8"h	VL0808LU
VL0808DRW	8"w x 8"h	Two Drawer / Shelf Kit ‡	8"w x 8"h	VL0808DRW
6 VL0808	8"w x 24"d	Compartment Shelf	8"w x 24"d	VL0808
7 NF6712	-	Double Prong Hook	-	NF6712
8 VL184BT	10"w x 24"d	Boot Tray	10"w x 24"d	VL244BT

STEP 3

Select Lower Drawer Unit and Accessories

ITEM No.	DIMENSIONS	ITEM	DIMENSIONS	ITEM No.
9 VL1836DRW	18"w x 36"d x 18"h	Lower Drawer Unit	24"w x 36"d 18"h	VL2436DRW
10 100760-18 x .75	18"w x .75"h	Hardwood Bench Top	24"w x .75"h	100760-24 x .75
11 VL1836DV	18"w x 24"d	Vest Shelf for Lower Drawer	24"w x 24"d	VL2436DV

STEP 4

Select Extra Accessories For Locker Door

ITEM	DIMENSIONS	ITEM No.
Clip Board Holder	-	VL2436DRW
12 Mirror with Magnetic Backing	7"w x 11"h	NFVLMIRROR
13 Belt Clips (3 pack)	-	VL2436DV

* A stand alone security compartment may be secured above or below a full width shelf when a partition kit is not used.

† Up to two additional shelves may be used above the partition kit.

‡ Compartment shelf (VL0808) is necessary to close the tops of these items unless mounted directly below a full shelf.

VALOR

SPECIFICATION SUMMARY

- 14-gauge one piece door
- 16-gauge frame
- 16-gauge body parts / 18-gauge backs
- Full loop type hinges
- Secure multi-point locking system
- Stainless steel recessed handles
- Built-in padlock loop
- Assembled - all seams & joints welded

NOTE: Upper unit shell ships separate from lower drawer unit and must be assembled in the field.

Accessories ship unassembled unless factory installation is requested.

POWDER COAT FINISH

Door, frame, and body parts shall be painted in one of Lyon's premier color options.

MATERIAL

Prime, high grade class 1 mild annealed, cold-rolled steel free from surface imperfections. A.S.T.M.-A1008.

Bolts to be zinc plated or subjected to other rust-retardant treatment.

UPGRADES

See pages 34 - 35 for more information on available upgrades such as:

- Galvannealed Lockers
- Antimicrobial Paint

Note: There are certain sizes and/or types of lockers that are available in minimum quantity production runs only. Contact your Lyon factory representative for complete details.



TA-50 LOCKER FEATURES

- Overall Size: 42"w x 24"d x 78"h
- Heavy-gauge "unibody" construction
- 14-gauge reinforced bottom, back, doors and sides
- 16-gauge steel top
- Diamond perforations on doors, sides, and back
- Chrome-plated, pad-lockable handle with a high security three-point latching system
- 16-gauge steel shelf with center reinforcing channel has weight capacity of 200 lbs



LATCHING SYSTEM



TURN HANDLE

The turn handle accepts a user provided padlock to secure the door closed.

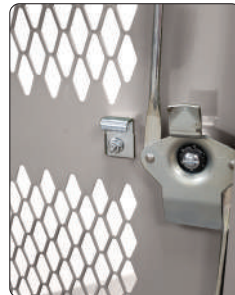

3-POINT LATCH

High security 3-point latching system engages the top and bottom of the frame as well as the left-hand door.

HANGING STORAGE



COAT ROD AND HOOKS

The full width, 1" diameter coat rod and four coat hooks attach to the full width shelf above allowing you to hang coats, uniforms, and heavy field dress.

TA-50

SPECIFICATION SUMMARY

- 14-gauge one piece doors
- 16-gauge body / 18-gauge top
- Continuous Hinges
- Diamond perforations on doors, back & sides
- Secure multi-point locking system
- Chrome-plated turn handle
- Built-in padlock hasp
- Assembled - all seams & joints welded

POWDER COAT FINISH

Door, frame, and body parts shall be painted in one of Lyon's premier color options.

MATERIAL

Prime, high grade class 1 mild annealed, cold-rolled steel free from surface imperfections. A.S.T.M.-A1008.

Bolts to be zinc plated or subjected to other rust-retardant treatment.

UPGRADES

See pages 34 - 35 for more information on available upgrades such as:

- Galvannealed Lockers
- Antimicrobial Paint

CSI formatted specifications available at lyonworkspace.com/architects

Note: There are certain sizes and/or types of lockers that are available in minimum quantity production runs only. Contact your Lyon factory representative for complete details.

CONSTRUCTION A heavy-duty, fully-ventilated, all-welded cabinet with finished measurements of 42" wide x 24" deep x 78" high. Unit ships fully assembled, except for the door handle assembly. All 16-gauge is cold rolled steel (A.S.T.M 1008) and all 14-gauge is hot-rolled pickled & oiled steel (A.S.T.M A569). Holes are pre-punched on the back and sides for attaching cabinets to each other and/or to a wall. Any fasteners used are not accessible from outside of cabinet. Perforated panels imitate the aesthetics and dimensions of expanded metal. This "Unibody" construction eliminates the potential of tearing stored items due to the sharp edges typically found on units featuring welded, expanded metal panels.

TOP Multi-formed 16-gauge steel with a return flange at front providing a built-in door stop.

BOTTOM Multi-formed 14-gauge steel with a return flange at front providing a built-in door stop. A center reinforcing channel is located side-to-side at the midpoint to allow for handling the cabinet with a typical wheeled dolly. The design provides for center-point floor anchoring at one of two locations.

BACK 14-gauge steel, diamond-perforated providing approximately 50% open space.

SIDES Multi-formed 14-gauge steel, diamond-perforated providing approximately 50% open space.

DOORS Multi-formed 14-gauge steel, diamond-perforated providing approximately 50% open space. The left door jamb features a vertical return providing a built-in door stop. The right door features a chrome-plated, padlockable handle with a high security three-point, three-sided latch consisting of two, 5/16" steel rods and a center locking disc assembly. Doors are bi-parting and pivot on 16-gauge, full-height, galvanized continuous hinges featuring a 1/8" pin and a 1" knuckle length.

SHELF Multi-formed 16-gauge steel featuring a center reinforcing channel located side-to-side at its midpoint resulting in a capacity of 200 lbs. The shelf is fastened through embossed holes in the side panels with (4) carriage bolts and flanged locknuts.

COAT ROD 1" diameter galvanized tube supported by three (3) galvanized angles resulting in a capacity of 100 lbs. The angles are attached to the shelf reinforcement with tapping screws.

COAT HOOKS Two single-prong zinc-plated hooks are mounted to each end flange of the shelf (4 total) with tapping screws.

NUMBER PLATE Optional aluminum plate, numbered in sequential order with etched figures, is field-riveted to the top of the right door panel (fasteners supplied).

FINISH After fabrication all steel parts are thoroughly cleaned, given a bonding and rust inhibitive phosphate treatment and electrostatically coated with a water-reducible enamel paint that is then heat-cured. Unless otherwise required, the color is Lyon "Dove Gray", or Lyon "Putty". All fasteners are zinc-plated.

HARDWARE All interconnecting (unit to unit) fasteners are supplied. All floor and wall anchors are provided by installer.

SHIPMENTS The packaging design has been developed around LEED requirements with minimal dunnage at its final destination point. It is based on fully-loaded (56 units), dedicated trailers.

OPTIONS

- Raw steel is available in a galvannealed finish. Lyon recommends that lockers utilized in high humidity or corrosive type atmospheres utilize this option. Add a "G" to end of part number; 1100TA50G
- For non-dedicated shipments less than 50 units per trailer, additional packaging is recommended. Packaging includes a wood shipping pallet, improved corner protection, nylon banding, and pre-assembly of the locking system. Add this number, in quantity, for each locker ordered; TA50PACKAGING

COMMAND GEAR

SPECIFICATION SUMMARY

- 16-gauge locker / 18-gauge backs
- 16-gauge frame
- 16-gauge full-width shelf
- Diamond perforations on sides
- Two 18-Gauge 5/8" dia. hanging rods
- Assembled - all seams & joints welded

OPTIONAL

- Two-Tone Finish

POWDER COAT FINISH

Doors, frame, and body parts shall be painted in one of Lyon's premier color options.

MATERIAL

Prime, high grade class 1 mild annealed, cold-rolled steel free from surface imperfections. A.S.T.M.-A1008.

Bolts to be zinc plated or subjected to other rust-retardant treatment.

UPGRADES

See pages 34 - 35 for more information on available upgrades such as:

- Galvannealed Lockers
- Antimicrobial Paint

CSI formatted specifications available at lyonworkspace.com/architects

Note: There are certain sizes and/or types of lockers that are available in minimum quantity production runs only. Contact your Lyon factory representative for complete details.



COMMAND GEAR LOCKER

This heavy-duty, all-welded locker offers a unique solution for storage and protection. The original design was inspired by military pilot's flight-related equipment storage needs.

This locker offers an open storage area for flight helmets as a large compartment to house a torso harness, G-suit/G-vest, survival vest and related flying equipment, jacket, and helmet bags. Lockable storage compartments provide additional security. The upper storage compartment can store smaller personal effects while the lower storage compartment is large enough for additional equipment.

- Overall Size: 24"w x 24"d x 72"h
- Small Storage with pull handle : 9"w x 15"h
- Large Storage with recessed handle: 24"w x 18"h
- 2 heavy-duty, 18-gauge, 5/8" diameter hanging rods for flight gear
- 2 side hooks for lighter gear
- Ventilated Sides
- Ships Assembled



COLLEGIATE LOCKER FEATURES

- Locker includes choice of one of Lyon's premier colors
- Constructed of 16-gauge steel with 18-gauge steel back
- Diamond perforated sides and solid back
- Full width 18-gauge upper shelf
- Coat rod with four single prong hooks
- Building block design to create the perfect locker

WIDTH	24 36
DEPTH	18 21 24
HEIGHT	72



collegiate

DELUXE COMPONENTS



SMALL COMPARTMENT

Easily secure personal items in the small compartment. The door is pre-punched to accept a number plate.

This compartment features a steel pull handle on the door. Easily add your own padlock or a built-in combination lock to secure the door closed.



BULK LOCK-UP

18" high bulk lock-up creates secure storage for bulkier items and gear. The hinged lid creates an instant bench seat within the locker.

The lid includes a hasp allowing you to easily add your own padlock to secure the items inside.



deluxe collegiate



OPTIONAL DOOR



VENTILATED DOOR

One-piece 14-gauge heavy-duty door features diamond perforations for ventilation. Three full loop type hinges secure the door to the frame.

The standard recessed handle includes a lift handle with a hasp that can be secured with a user provide padlock.



collegiate with door



deluxe collegiate with door

LYON[®] LOCKERS

COLLEGIATE

SPECIFICATION SUMMARY

- 16-gauge locker / 18-gauge backs
- 16-gauge frame
- 16-gauge full-width shelf
- Diamond perforations on sides
- Available factory assembled, unassembled, or all-welded

OPTIONAL

- Full Height Ventilated Door
- Bulk Lock-up*
- Security Box*

**compartments ship unassembled unless factory installation is requested.*

POWDER COAT FINISH

Doors, frame, and body parts shall be painted in one of Lyon's premier color options.

MATERIAL

Prime, high grade class 1 mild annealed, cold-rolled steel free from surface imperfections. A.S.T.M.-A1008.

Bolts to be zinc plated or subjected to other rust-retardant treatment.

UPGRADES

See pages 34 - 35 for more information on available upgrades such as:

- Galvannealed Lockers
- Antimicrobial Paint

CSI formatted specifications available at lyonworkspace.com/architects

Note: There are certain sizes and/or types of lockers that are available in minimum quantity production runs only. Contact your Lyon factory representative for complete details.

LOCKERACK

Provide coat storage and lock-up compartments for 16 people in approximately one square foot per person! Perfect for break rooms and offices

- Locker openings 12"w x 18"d x 12"h
- Overall Dimensions 69"w x 18"d x 78"h
- 16-gauge locker frame construction
- Five knuckle hinge for long lasting, secure use
- Pull handles with built-in padlock attachment
- 6" legs for additional toe room below the locker
- Horizontal 4 door wall mounted unit also available 45"w x 18"d 13-3/4"h
- Available in Putty or Dove Gray
- Ships assembled or unassembled



CLEAR SIGHT LOCKERS



ClearSight Lockers provide paramount security while also offering a transparent view. These clear polycarbonate lockers are ideal for locations that require security, yet also need visibility to the stored contents. These doors meet flammability standards, making the ClearSight locker ideal for retail, pharmaceutical, institutional, and personal use.

- Includes high-strength injection molded polycarbonate doors
- Locker openings 12"w x 18"d x 12"h
- 16-gauge locker frame construction
- Five knuckle hinge for long lasting, secure use
- Pull handles with built-in padlock attachment
- 6" legs for additional toe room below the locker
- Available in 5 tier, 6 tier, and 16-door configurations
- Available in Putty or Dove Gray
- Ships assembled or unassembled

DIGITAL LOCKERS

Lyon's digital locker with keyless electronic locks is ideal for offices and workplaces all over! The 18 doors feature a slimline, small footprint code lock. These public use locks allow a user to create their own 4-digit code to secure their items. Once the items are retrieved, the lock resets and is ready for the next independent user.

- Locker openings 12"w x 18"d x 12"h
- Overall Dimensions 36"w x 18"d x 78"h
- 16-gauge locker frame construction
- Five knuckle hinge for long lasting, secure use
- 6" legs for additional toe room below the locker
- Available in Putty
- Ships assembled



CELL PHONE LOCKERS

Easily add quick cell phone storage for any facility! Lyon's cell phone locker features a slim 9" wide frame and is available in 1-wide or 3-wide units. The 6" high legs provide additional toe room beneath the locker.

Add number plates to the pre-punched doors to help quickly identify each locker. Lockers are available with either a padlock hasp with friction catch or with electronic locks.

- Overall Frame Size: 9"w x 18"d x 78"h
- Locker openings 6-1/2"w x 6-3/4"h
- 18-gauge doors / 16-gauge locker frame
- 24-gauge body
- Full height, continuous hinge
- 6" legs for additional toe room below the locker
- Available in Putty
- Ships assembled



WALL MOUNTED CELL PHONE LOCKERS

Easily add quick cell phone storage for your facility with the Lyon cell phone locker. This locker includes 14 individual use doors with USB charging outlets. The master door provides access to all the openings at once. Each locker includes mounting brackets to easily hang the unit on the wall and keep your floor space clear.

Each opening includes a secured USB A charging outlet mounted to the back of the locker. The bottom, center door houses the converter. The AC plug for the converter can be routed out through the bottom or the back of the cell phone locker and plugs into a standard outlet.



- Locker openings 6-1/2"w x 6-3/4"h
- Overall Dimensions 27"w x 9"d x 39"h
- 18-gauge doors, 24-gauge body parts
- Steel padlock hasps with friction catch
- Master door with locking handle & 2 keys
- Wall mounting brackets
- 14 USB A charging outlets & converter
- Includes number plates 1-14 (ships loose)
- Available in Monorail Gray
- Ships assembled



LYON[®] LOCKERS

EMPLOYEE

APPLICATIONS

Lyon offers a huge selection of metal employee lockers that are sure to fit your needs. Our steel lockers come with 4 to 16 doors. Easily offer a secure place for your employees to store their personal items. It provides your staff the peace of mind that their personal effects are safe and sound.

Providing personal lockers allows your employees to store phones, lunches, and handbags. Provide your workers a place to keep their items safe while on the job. These work lockers are great options for offices, break rooms, and common areas.

POWDER COAT FINISH

Door, frame, and body parts shall be painted in one of Lyon's standard stock color.

MATERIAL

Prime, high grade class 1 mild annealed, cold-rolled steel free from surface imperfections. A.S.T.M.-A1008.

Bolts to be zinc plated or subjected to other rust-retardant treatment.

A LITTLE OR A LOT

Many of our employee lockers are stocked and ready to ship to fulfill quick small orders. Have a bigger project? Lyon can help you determine which type of locker and how many will be the best fit for your project.

Note: There are certain sizes and/or types of lockers that are available in minimum quantity production runs only. Contact your Lyon factory representative for complete details.

BENCHES

POWDER COAT FINISH

Steel and cast iron locker pedestals shall be painted in one of Lyon's premier color options. Anchoring and hardware will be unpainted.

MATERIAL

Prime, high grade class 1 mild annealed, cold-rolled steel free from surface imperfections. A.S.T.M.-A1008.

Bolts to be zinc plated or subjected to other rust-retardant treatment.

BENCH TOPS

HARDWOOD TOP is made of multiple hardwoods for maximum strength. Each bench top is finished with two coats of clear acrylic to protect the bench top from scratches. The bench top is 9-1/2" deep by 1-1/4" thick. Available in lengths from 3 to 12 feet long. Can be used with any Lyon bench pedestal.

PLASTIC LAMINATE TOP features a particle board core with a plastic laminate over it. Long sides of the bench top have a full 180° soft edge. Bench top is 12" deep by 1-5/8" thick. Available in lengths from 3 to 12 feet long. Can be used with steel, cast iron, or trapezoid pedestals. Select laminate colors are available to compliment Lyon's premier color options.

ALUMINUM BENCH TOP is made of aluminum alloy with a clear anodic coating. The easy to maintain bench planks have softly rounded edges and center braces for comfortable seating. Bench top is 9-1/2" deep by 1-3/4" thick. Available in lengths 6 to 12 feet long. Can be used with aluminum pedestals.



Hardwood



Plastic Laminate



Aluminum

BENCH PEDESTALS

STEEL PEDESTALS feature 14-gauge steel with 1-5/8" tubing uprights. Includes 8-1/4" diameter base on top and bottom of the pedestal. Finish shall be the same powder coat color as lockers. Pedestals shall be spaced on not more than 6' centers. Overall height is 16-1/2" high.

CAST IRON HEAVY-DUTY PEDESTALS features single piece cast iron construction with 3/16" material thickness. 2-1/4" post with 6" diameter base on top and bottom of the pedestal. Finish shall be the same powder coat as lockers. Pedestals shall be spaced on not more than 6' centers. Overall height is 16-1/4" high.

ALUMINUM PEDESTALS Made of lightweight, corrosion resistant anodized aluminum. Constructed of two pieces of formed and unit-welded 2-1/4" x 3/4" aluminum extrusion. 11-5/8" x 2-1/4" base on bottom of the pedestal. Overall height is 15-14" high. Add optional rubber feet to make pedestal moveable.

ALUMINUM TRAPEZOID PEDESTALS Made of 1/4" x 3" bar stock and features black anodized finish. The 13-9/16" wide base and anti-slip strips makes this moveable pedestal more stable. Maximum bench overhang from middle of pedestal must not exceed 6 inches. Overall height is 16-1/4" high.



Steel



Cast Iron



Aluminum



Trapezoid

ADA BENCHES

ADA compliant locker room benches meet the accessibility requirements of sections 222 and 803 of the 2010 ADA standards. ADA compliant benches feature hardwood tops. Benches are available with or without a backrest. Either steel or cast iron pedestals can be used for ADA benches.



Note: There are certain sizes and/or types of lockers that are available in minimum quantity production runs only. Contact your Lyon factory representative for complete details.

LOCKS AND NUMBER PLATES

Aluminum Number Plates with black numbers are 2-3/4" w x 1" h.



Lock Options can be used with all handles, and retrofitted to existing installations.



END PANELS

STANDARD SIDESHEET

Lockers come standard with sidesheets that are pre-punched to fit several tier and shelf placements. Having a variety of pre-punched holes provides the flexibility to adjust shelves and hooks in the field as needed to accommodate ADA regulations.

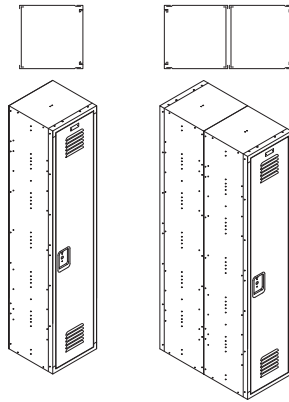

END COVER PANELS

Easily installed on exposed ends of lockers for increased durability and an enhanced appearance. End cover panels attach over a side sheet and show only vertical frame bolt heads. End cover panels can have the same color finish as the locker door and frame.

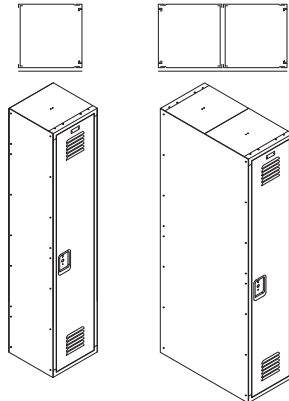

END FINISH PANELS

End finish panels are a boxed panel that bolt to an end locker from the inside. No bolt heads are exposed on the outside giving the end row a smooth and finished look. End finish panels can have the same color finish as the locker door and frame.

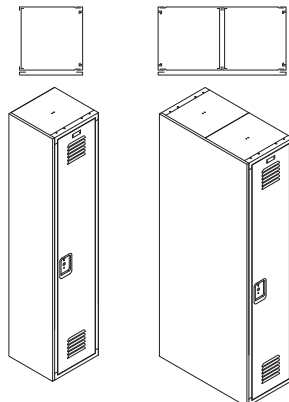

LYON[®] LOCKERS

FINISHING ACCESSORIES

POWDER COAT FINISH

Locker accessories shall be painted in one of Lyon's premier color options. Anchoring and hardware will be unpainted.

MATERIAL

Prime, high grade class 1 mild annealed, cold-rolled steel free from surface imperfections. A.S.T.M.-A1008.

Bolts to be zinc plated or subjected to other rust-retardant treatment.

Note: There are certain sizes and/or types of lockers that are available in minimum quantity production runs only. Contact your Lyon factory representative for complete details.

SLOPING HOOD

Continuous Sloping Hoods mount on one or more standard flat top lockers.

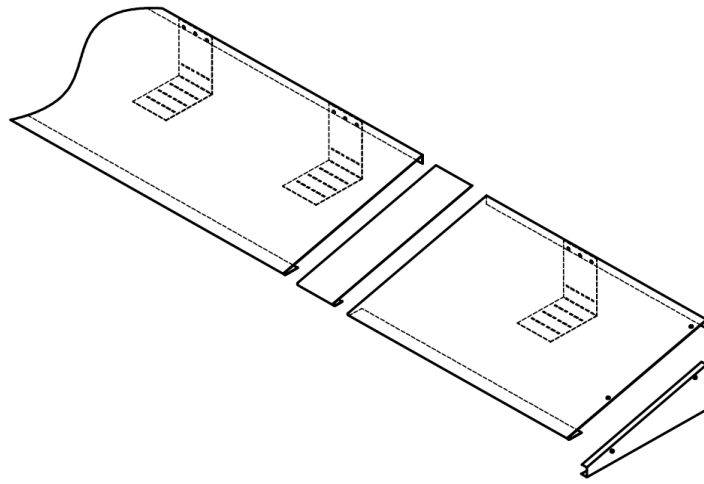

SLOPE TOP CORNERS

OUTSIDE SLOPE TOP CORNER

Outside Slope Top Corners provide a finished look and merge two sections of sloped hood at the end.

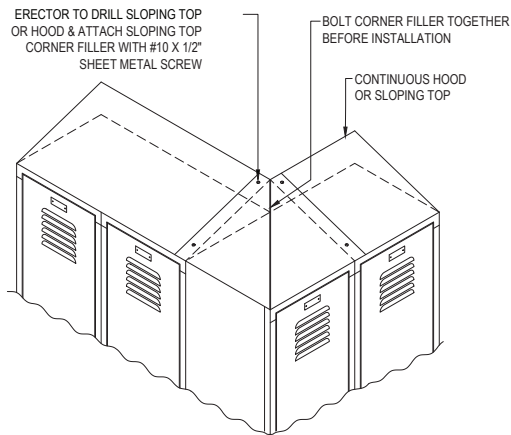

INSIDE SLOPE TOP CORNER

Inside Slope Top Corners provide a finished look and close corner gaps where two lockers meet.

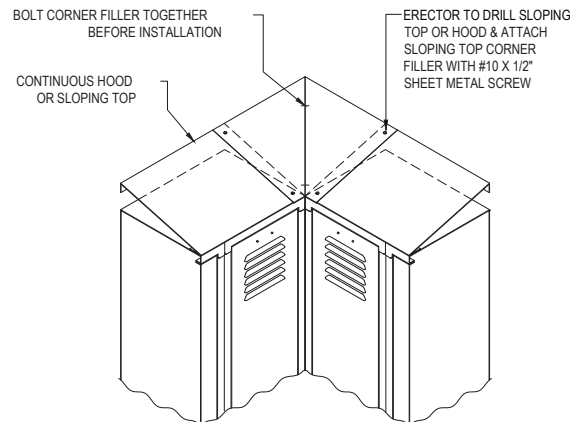

INNER CORNER TIE ANGLES

Inner Corner Tie Angles provide a finished look and tie banks together for long-term stability.

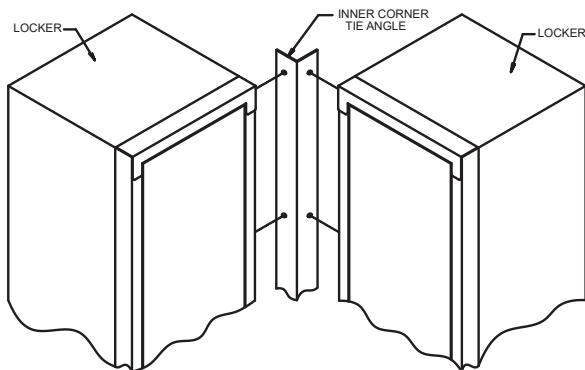

RECESS TRIM

End and top recess trim for lockers are placed in wall recesses with 18-gauge formed steel with a 3" wide face and are bolted to locker frames. Top recess trim are available in approximately 60" lengths with a formed splice cap to cover joints and to hold top recess trim in alignment. End recess trim are 3" higher than lockers and will lap over ends of top recess trim for a hairline joint at top of corners.

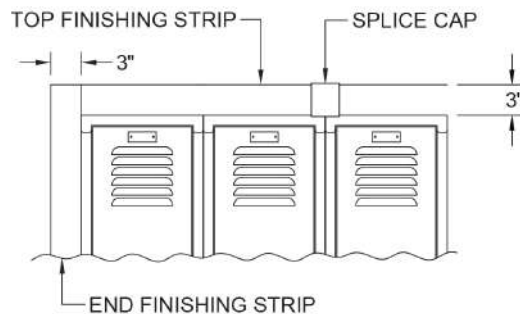

CLOSURES AND FILLERS

FRONT EXPANSION FILLERS

Used to fill space between two locker fronts. Two piece construction permits adjustment to fit space. Fillers can also be used to fill space between the locker and a wall.

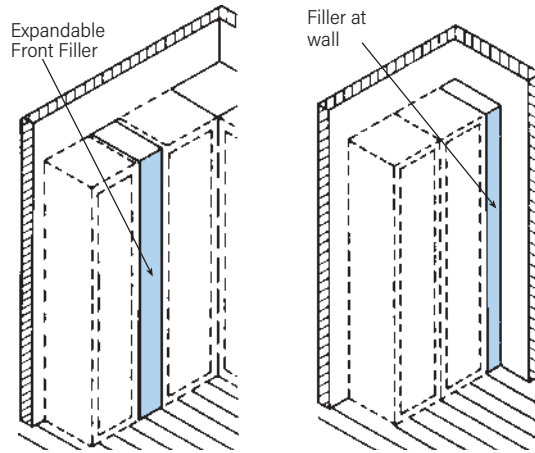

CLOSURE STRIPS

Used to fill space at ends and tops of installation between lockers and wall or between two rows of lockers. Available for flat or slope top lockers. It is important to specify space to be closed for proper fit.

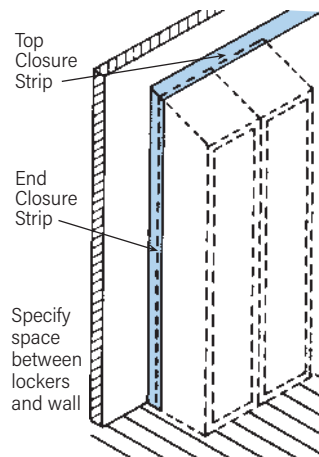

TOP CLOSURES AND FILLERS

Top Closures are used to close space between two tops when obstruction prevents installation of a locker. Can be furnished on flat or sloping tops.

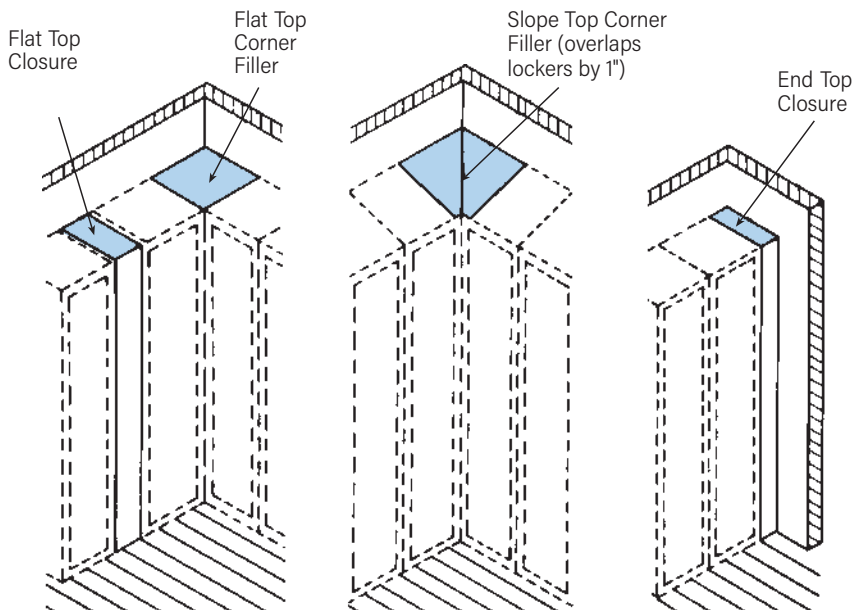

FINISHING ACCESSORIES

POWDER COAT FINISH

Locker accessories shall be painted in one of Lyon's premier color options. Anchoring and hardware will be unpainted.

MATERIAL

Prime, high grade class 1 mild annealed, cold-rolled steel free from surface imperfections. A.S.T.M.-A1008.

Bolts to be zinc plated or subjected to other rust-retardant treatment.

Note: There are certain sizes and/or types of lockers that are available in minimum quantity production runs only. Contact your Lyon factory representative for complete details.

ANCHORING AND BASES

POWDER COAT FINISH

Locker accessories shall be painted in one of Lyon's premier color options. Anchoring and hardware will be unpainted.

MATERIAL

Prime, high grade class 1 mild annealed, cold-rolled steel free from surface imperfections. A.S.T.M.-A1008.

Bolts to be zinc plated or subjected to other rust-retardant treatment.

ANCHORING

ANCHORING ANGLE

For Lockers Without Legs

Use a locker anchoring angle (running from front to rear on the inside bottom of the locker) providing a bearing surface for the fasteners which are connected to the floor or locker base. For the typical continuous row locker installation, order one locker anchoring angle for each end of a row, plus sufficient quantity to provide angles on 36" centers. On single row installations where backs are against a wall, lockers should be suitably wall anchored as detailed in assembly instructions packed with lockers and below installation drawings.

- No. 5872 - For 12"d lockers
- No. 5873 - For 15"d lockers
- No. 5874 - For 18"d lockers
- No. 5875 - For 21"d lockers



LOCKER FOOT

For Lockers With legs

When backs are exposed (free standing) a locker foot is recommended for all locker legs. When backs are against a wall and suitably wall anchored, locker feet are recommended on front legs only. For more details, see assembly instructions packed with lockers.

No. 5870



BASES

Z BASE

Used for locker without legs Z Type Bases offer added toe space and effective support using rugged 14-gauge steel. Adds 4" to overall locker height.



CLOSED BASE

Used for lockers with 6" high legs. Quickly give lockers a clean and finished look while preventing items from rolling underneath. Front bases and end bases install easily without tools.



Front Base



End Base

Note: There are certain sizes and/or types of lockers that are available in minimum quantity production runs only. Contact your Lyon factory representative for complete details.

LEED INITIATIVE

LEED provides building owners and operators a concise framework for identifying and implementing measurable green building design, construction, operations, and maintenance solutions. Lyon prides itself on being an organization that is environmentally responsible by using environmentally friendly materials in our products and having environmentally sound practices and procedures in the workplace. Lyon products are manufactured from steel that contains a conservatively overall estimated 53% recycled steel (36% post-consumer, 17% pre consumer). We purchase steel from both integrated and mini mills throughout the United States. In addition, our packaging materials are made from either recycled or recyclable materials.

Lyon also participates in recycling programs with regard to our waste products generated during the purchase and consumption of raw materials and the manufacture of products in order to maintain our position as an environmentally friendly and responsible organization.

As an organization that takes pride in being sensitive to our environment, we continually work towards finding new ways to provide products to customers that are environmentally friendly and maintain procedures in the workplace that do the same.

Lyon is committed to developing products as well as programs that positively impact the environment. We are the clear cut leader in green initiatives with our goals to create healthier environments. We strive to lower operating costs, reduce emissions, as well as maintain an enviro-friendly product delivery system. Our centrally located manufacturing facilities also stand within 500 miles of many metro areas for fuel-efficient deliveries. LEED provides building owners and operators a concise framework for identifying and implementing measurable green building design, construction, operations, and maintenance solutions. Lyon also set initiatives in place to reduce our environmental footprint.

QUALIFYING CREDITS

Materials and Resources

Recycled Content:

MR Credits 4.1 and 4.2

Indoor Environmental Quality

Low-Emitting Materials Painting:

VOC-Compliant Paints & Coatings Credit 4.2

Sustainable Sites

Reduced Site Disturbance:

Development Footprint – Credit 5.2

ADDITIONAL CREDITS

Manufactured Regionally

Regionally-sourced Products:

MR Credits 5.1 and 5.2

The project location must be within 500 miles of the Lyon LLC manufacturing plant to qualify for this credit. Use the project site address to calculate the distance from:

Montgomery, IL

Paris, IL

Watseka, IL

RESOURCES

SPECIFICATIONS & GUIDES

Visit the Lyon website for all downloads pertinent to your project

lyonworkspace.com/architects

SPECIFICATIONS

Locker specification pdfs

CSI formatted specifications

PROJECT DOCUMENTS

Locker Maintenance and Care

LEED Info

Product Warranty

Safety Data Sheets

PRODUCT GUIDES

Premier Color Chart

Locker ADA Compliance Guide

Locker Replacement Parts

Note: There are certain sizes and/or types of lockers that are available in minimum quantity production runs only. Contact your Lyon factory representative for complete details.

ADA LOCKER GUIDELINES

Lyon has long been America's leading manufacturer of quality steel ADA accessible lockers. The Americans with Disabilities Act (ADA) specifies certain requirements that affect metal lockers. To comply with these ADA standards at least 5% of the lockers provided, but no less than one locker needs to meet the ADA requirements. Lockers can be ordered ADA compliant, or shelves can be added and relocated to make an existing locker meet ADA regulations.

ADA Lockers must meet the following guidelines:

- Doors must be able to be opened without a twisting or clasping motion. (The standard test for this compliance is if the door can be opened with closed fingers)
- The locker shelf or hooks cannot exceed 48" from the finished floor
- The locker bottom must be a minimum of 15" from the finished floor (An additional shelf can be added to create a false bottom)
- Locker shelves can be repositioned and additional shelves can be purchased separately if necessary



ADA SHELF HEIGHT REQUIREMENTS

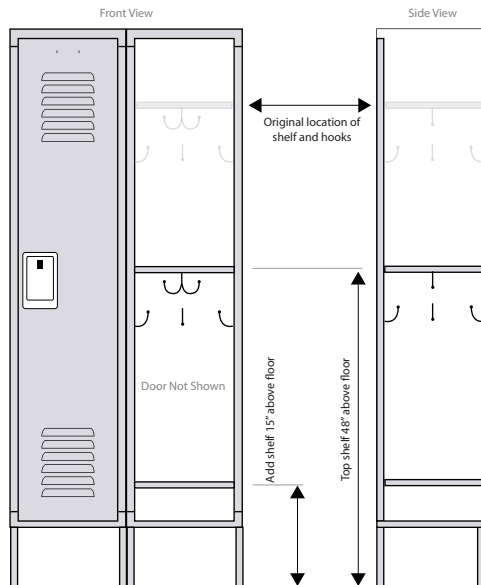

SINGLE TIER LOCKER

For single tier lockers, the shelf and coat hooks must be lowered to no more than 48" above the finished floor.

An extra shelf needs to be added to bring the bottom of the locker to no lower than 15" above the finished floor.

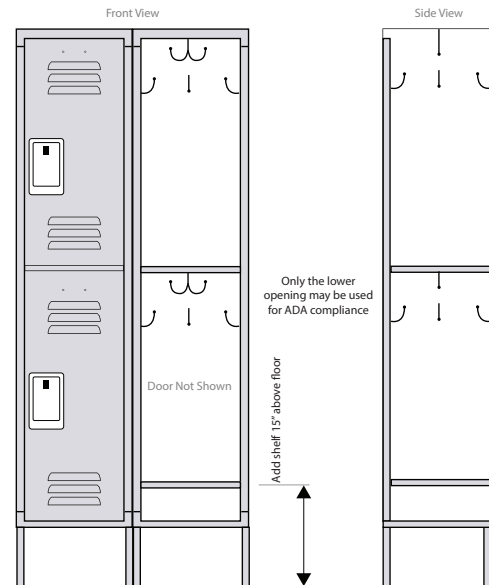

DOUBLE TIER LOCKER

On double tier lockers, an extra shelf needs to be added to bring the bottom of the locker to no lower than 15" above the finished floor.

Only the lower opening may be used for ADA compliance.

ADA HANDLE REQUIREMENTS

Lyon offers both standard recessed handles with lift as well as pull handles which can easily be opened with a closed fist. Both handles can accommodate a built-in lock or a user provide lock. ADA lock options are available on request.



STAINLESS STEEL RECESSED HANDLE

Standard on single, double and triple-tier lockers with lockbar.

One piece recessed handle pockets add strength to the handle area and eliminate the vulnerable seams of formed handles. The lift handle includes a hasp that can be secured with a user provide padlock.



PULL HANDLE

Standard on multiple tier lockers. A built-in padlock loop easily accepts a user provided padlock.

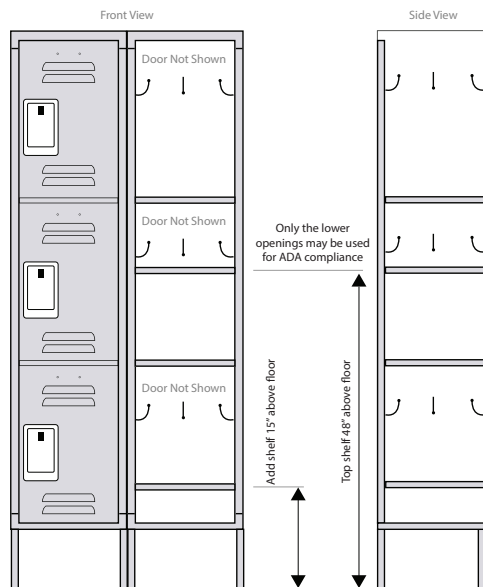

TRIPLE TIER LOCKER

On triple tier lockers, an extra shelf needs to be added to bring the top of the middle locker to 48" above the finished floor.

An extra shelf needs to be added to the bottom of the lower locker to no lower than 15" above the finished floor.

Only the middle and bottom lockers can be used for ADA compliance.

ADA LOCKER GUIDELINES



SPECIFICATION SUMMARY

Single tier, double tier, and triple tier lockers can be ADA compliant with the appropriate shelf placement.

Standard recessed handles and standard steel pull handles meet ADA regulations.

Optional handicap decal to add to the outside or inside of a designated ADA locker is also available.

MATERIAL

Prime, high grade class 1 mild annealed, cold-rolled steel free from surface imperfections. A.S.T.M.-A1008.

Bolts to be zinc plated or subjected to other rust-retardant treatment.

Note: There are certain sizes and/or types of lockers that are available in minimum quantity production runs only. Contact your Lyon factory representative for complete details.

STANDARD OPTION

OPTIONAL UPGRADE

<p>Single, double, and triple tier lockers come standard with a lockbar and stainless steel recessed handle. This handle includes a finger lift with a hasp that can be secured with a user provide padlock. Built-in locks can also be used.</p>	<h3>HANDLES</h3>	<p>A Zinc Recessed Lift Handle that is cast and stronger is available to use with lockbars.</p> <p>Single Point Recessed Handle operates with no additional moving parts or lockbar. Zinc option also available.</p>
<p>Prime, high grade Class 1 mild annealed, cold-rolled steel free from surface imperfections.</p>	<h3>STEEL</h3>	<p>Galvannealed steel available for high humidity atmospheres. Select only the locker bottoms or the entire locker to be made of galvannealed steel.</p>
<p>Single, double, and triple tier locker come standard with 6" w louvers. Multiple tier lockers come standard with 3-1/2" w louvers.</p>	<h3>LOUVERS</h3>	<p>Diamond perforations provide thorough ventilation and allow quick inspection of locker contents. Mini Louvers provide ventilation with increase security by eliminating visibility of locker contents. Smooth doors with no louvers is also an option.</p>

LOUVER PATTERNS

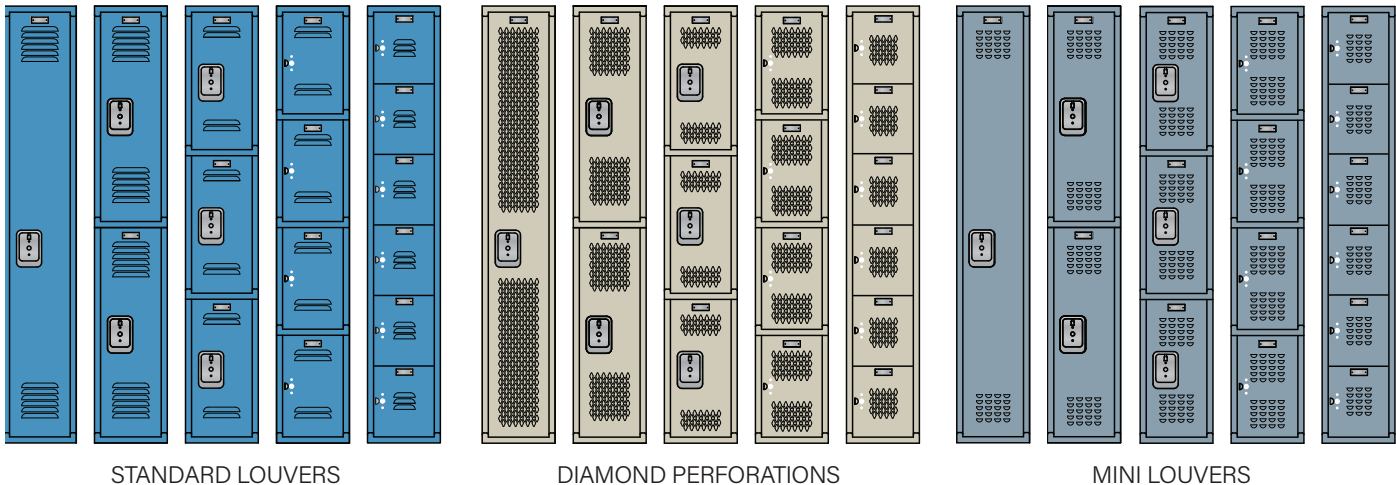

NANO ROLLER LATCHING SYSTEM

For unmatched security, nano metal roller latching system is now standard on single, double and triple-tier lockers. Vandalism and break-in theft are serious problems for schools, businesses and industrial organizations.

Lyon Engineers have developed a patent pending locker latching system that utilizes nano metal roller technology to provide break-in protection compared to existing locker latching systems.

Nylon tamper-resistant lockbar guide ensures proper lockbar alignment for smooth operation, while reducing overall noise by eliminating metal-to-metal contact. Nano rollers ride effortlessly up the door jambs and drop into place, providing break-in protection compared to other locker latching systems. (Note: for demonstration purposes, top nano roller has been lowered into close proximity with locker handle.)

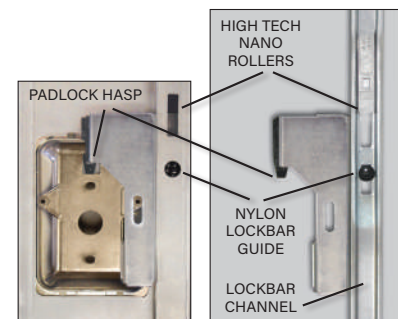

- Zamak 3 zinc alloy latch finger for up to four times the tensile strength than nylon.
- The nano metal roller latch is spring loaded for smooth and flawless performance.

PREMIUM COLOR OPTIONS



Locker body parts are standard in Putty unless otherwise noted.

Lyon's Premier color selections and/or a computerized match to your custom color offer a virtually endless combination of choices including two tone effects. Our preparation and finishing procedures deliver a superior surface, highly resistant to deterioration and corrosion, to create a lasting impression for your locker installation.

Note: All color chips approximate the actual color as closely as possible. For a more precise color match, request a free color chart showing Lyon's 34 premier colors.

LYON LOCKERS

POWDER COAT

ANTIMICROBIAL UPGRADE

FIGHT BACTERIAL AND MOLD GROWTH!

Antimicrobial lockers are recommended for healthcare, industrial, food processing plants, and educational facilities of all types.

Antimicrobial steel lockers provide continuous protection against the touch transfer of bacteria on the locker surface, as well as colonization of mold and bacteria in the corners, seams and on hidden surfaces behind and under the locker.

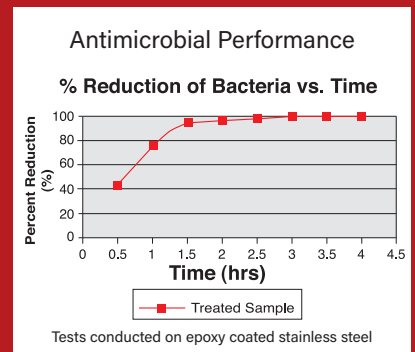

HOW DOES IT WORK?

Any moisture triggers the controlled release of powerful silver ions (see charts) to provide superior antimicrobial protection for decades.

The antimicrobial compound is completely inorganic, less toxic than ordinary table salt, less irritating than talcum powder, and has been approved by the EPA, FDA and NSF for medical devices.

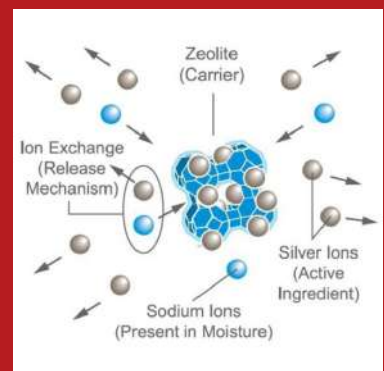

THE STANDARD OF EXCELLENCE

For over a century, Lyon has been the nation's leading steel locker manufacturer. Since 1901, Lyon has been committed to producing high-quality lockers that provide security and durability for a range of industries. With an unwavering focus on innovation and customer satisfaction, Lyon has remained a trusted name in lockers and storage solutions.

Whether you need lockers for a school, gym, or workplace, Lyon's team of skilled designers have the knowledge and practical experience to create tailored solutions to meet your unique needs.



LYON[®]

P.O. Box 671
Aurora, IL 60507-0671

800-323-0082
lyon@lyonworkspace.com
lyonworkspace.com