

# GANTRY AND JIB CRANES



**STEEL GANTRY CRANES**



**ALUMINUM GANTRY CRANES**



**HOISTS & TROLRIES**



**JIB CRANES**



**SPREADER BEAMS**

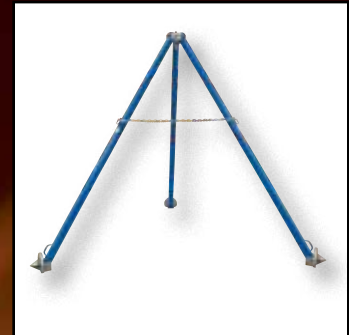

**TRIPOD HOIST STANDS**

Steel Gantry Cranes <b>v</b> .....	202-204, 207
Aluminum Gantry Cranes <b>v</b> .....	205-206
Floor, Wall, Ceiling Jibs <b>v</b> .....	207-209
Beam Clamps <b>i</b> .....	209
Trolleys <b>i</b> .....	210
Lever Hoists <b>i</b> .....	211
Hoists <b>v</b> <b>i</b> <b>i</b> .....	212-214
Clamps & Tongs <b>i</b> .....	215-217
Spreader Beams <b>v</b> .....	219
Overhead Load Lifters <b>v</b> .....	220
Crane Scales <b>i</b> .....	220
Jib Cranes <b>v</b> <b>i</b> .....	221-222
Engine Hoists & Floor Cranes <b>v</b> <b>i</b> .....	223-224
Tripod Hoist Stands <b>v</b> .....	225
Winches <b>i</b> .....	226
Magnets <b>i</b> <b>i</b> .....	227
Gantry Crane Survey Sheet .....	228



ADJUSTABLE HEIGHT  
GANTRY CRANES  
series AHS

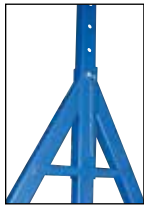

Steel Gantry  
Cranes are  
adjustable left/right  
and up/down.



4-POSITION 8"  
SWIVEL CASTERS  
(standard)



OPTIONAL  
TOTAL LOCKING CASTERS  
model AHS-2/4-TLC  
(FOR 2,000 AND 4,000 LB. CAPACITY  
CRANES ONLY)  
model AHS-6/8-TLC  
(FOR 6,000 AND 8,000 LB. CAPACITY  
CRANES ONLY)



OPTIONAL  
V-GROOVE CASTERS  
model AHS-2/4-V  
(FOR 2,000 AND 4,000 LB.  
CAPACITY CRANES ONLY)



OPTIONAL  
V-GROOVE CASTERS  
model AHS-6/8-V  
(FOR 6,000 AND 8,000 LB.  
CAPACITY CRANES ONLY)

## Adjustable Steel Gantry Cranes

Adjustable Steel Gantry Cranes are designed for positioning materials along the beam's length. Facilitate easy mobility from one area to another with four (4) 8" swivel casters with four-position locks. 2K-4K models have glass filled nylon casters, 6K-8K models have phenolic casters, and 10K model has steel casters. Ratchet for easy one person height adjustment. Height is adjustable in 6" increments. Do not move units while loaded. Painted blue finish. Designed for semi-permanent or permanent applications. Requires assistance from fork truck to set-up. Hoist and trolley can be ordered separately, see pages 210-214.

MODEL NUMBER	UNIFORM CAPACITY	OVERALL I-BEAM LENGTH / HEIGHT	I-BEAM FLANGE WIDTH	UNDER I-BEAM USABLE HEIGHT	BASE WIDTH	WEIGHT (POUND)
AHS-2-10-12	2,000 lb.	10' / 6"	4"	7'6" to 12'	76 <sup>1</sup> / <sub>8</sub> "	828
AHS-2-10-14	2,000 lb.	10' / 6"	4"	8'6" to 14'	88 <sup>1</sup> / <sub>2</sub> "	898
AHS-2-10-16	2,000 lb.	10' / 6"	4"	10'6" to 16'	88 <sup>1</sup> / <sub>2</sub> "	930
AHS-2-15-7	2,000 lb.	15' / 6"	4"	5' to 7'	46 <sup>3</sup> / <sub>8</sub> "	716
AHS-2-15-9	2,000 lb.	15' / 6"	4"	6' to 9'	58 <sup>3</sup> / <sub>8</sub> "	774
AHS-2-15-10	2,000 lb.	15' / 6"	4"	6'6" to 10'	64 <sup>1</sup> / <sub>4</sub> "	778
AHS-2-15-12	2,000 lb.	15' / 6"	4"	7'6" to 12'	76 <sup>1</sup> / <sub>8</sub> "	875
AHS-2-15-14	2,000 lb.	15' / 6"	4"	8'6" to 14'	88 <sup>1</sup> / <sub>2</sub> "	954
AHS-2-15-16	2,000 lb.	15' / 6"	4"	10'6" to 16'	88 <sup>1</sup> / <sub>2</sub> "	1020
AHS-2-20-12	2,000 lb.	20' / 10 <sup>1</sup> / <sub>8</sub> "	4"	7'6" to 12'	76 <sup>1</sup> / <sub>8</sub> "	1074
AHS-2-20-14	2,000 lb.	20' / 10 <sup>1</sup> / <sub>8</sub> "	4"	8'6" to 14'	88 <sup>1</sup> / <sub>2</sub> "	1163
AHS-2-20-16	2,000 lb.	20' / 10 <sup>1</sup> / <sub>8</sub> "	4"	10'6" to 16'	88 <sup>1</sup> / <sub>2</sub> "	1194
AHS-4-10-12	4,000 lb.	10' / 8 <sup>1</sup> / <sub>8</sub> "	4"	7'6" to 12'	76 <sup>1</sup> / <sub>8</sub> "	860
AHS-4-10-14	4,000 lb.	10' / 8 <sup>1</sup> / <sub>8</sub> "	4"	8'6" to 14'	88 <sup>1</sup> / <sub>2</sub> "	925
AHS-4-10-16	4,000 lb.	10' / 8 <sup>1</sup> / <sub>8</sub> "	4"	10'6" to 16'	88 <sup>1</sup> / <sub>2</sub> "	962
AHS-4-15-7	4,000 lb.	15' / 8 <sup>1</sup> / <sub>8</sub> "	4"	5' to 7'	46 <sup>3</sup> / <sub>8</sub> "	739
AHS-4-15-9	4,000 lb.	15' / 8 <sup>1</sup> / <sub>8</sub> "	4"	6' to 9'	58 <sup>3</sup> / <sub>8</sub> "	816
AHS-4-15-10	4,000 lb.	15' / 8 <sup>1</sup> / <sub>8</sub> "	4"	6'6" to 10'	64 <sup>1</sup> / <sub>4</sub> "	846
AHS-4-15-12	4,000 lb.	15' / 8 <sup>1</sup> / <sub>8</sub> "	4"	7'6" to 12'	76 <sup>1</sup> / <sub>8</sub> "	930
AHS-4-15-14	4,000 lb.	15' / 8 <sup>1</sup> / <sub>8</sub> "	4"	8'6" to 14'	88 <sup>1</sup> / <sub>2</sub> "	1055
AHS-4-15-16	4,000 lb.	15' / 8 <sup>1</sup> / <sub>8</sub> "	4"	10'6" to 16'	88 <sup>1</sup> / <sub>2</sub> "	1068
AHS-4-20-12	4,000 lb.	20' / 12 <sup>3</sup> / <sub>16</sub> "	4"	7'6" to 12'	76 <sup>1</sup> / <sub>8</sub> "	1076
AHS-4-20-14	4,000 lb.	20' / 12 <sup>3</sup> / <sub>16</sub> "	4"	8'6" to 14'	88 <sup>1</sup> / <sub>2</sub> "	1155
AHS-4-20-16	4,000 lb.	20' / 12 <sup>3</sup> / <sub>16</sub> "	4"	10'6" to 16'	88 <sup>1</sup> / <sub>2</sub> "	1204
AHS-6-10-12	6,000 lb.	10' / 8 <sup>1</sup> / <sub>8</sub> "	4"	7'7" to 12'1"	77 <sup>3</sup> / <sub>8</sub> "	927
AHS-6-10-14	6,000 lb.	10' / 8 <sup>1</sup> / <sub>8</sub> "	4"	8'7" to 14'1"	89 <sup>3</sup> / <sub>4</sub> "	1045
AHS-6-10-16	6,000 lb.	10' / 8 <sup>1</sup> / <sub>8</sub> "	4"	10'7" to 16'1"	89 <sup>3</sup> / <sub>4</sub> "	1022
AHS-6-15-7	6,000 lb.	15' / 10 <sup>1</sup> / <sub>8</sub> "	4"	5'1" to 7'1"	47 <sup>5</sup> / <sub>8</sub> "	810
AHS-6-15-9	6,000 lb.	15' / 10 <sup>1</sup> / <sub>8</sub> "	4"	6'1" to 9'1"	59 <sup>5</sup> / <sub>8</sub> "	894
AHS-6-15-10	6,000 lb.	15' / 10 <sup>1</sup> / <sub>8</sub> "	4"	6'7" to 10'1"	65 <sup>1</sup> / <sub>2</sub> "	932
AHS-6-15-12	6,000 lb.	15' / 10 <sup>1</sup> / <sub>8</sub> "	4"	7'7" to 12'1"	77 <sup>3</sup> / <sub>8</sub> "	1017
AHS-6-15-14	6,000 lb.	15' / 10 <sup>1</sup> / <sub>8</sub> "	4"	8'7" to 14'1"	89 <sup>3</sup> / <sub>4</sub> "	1108
AHS-6-15-16	6,000 lb.	15' / 10 <sup>1</sup> / <sub>8</sub> "	4"	10'7" to 16'1"	89 <sup>3</sup> / <sub>4</sub> "	1168
AHS-6-20-12	6,000 lb.	20' / 12 <sup>5</sup> / <sub>16</sub> "	6 <sup>1</sup> / <sub>2</sub> "	7'7" to 12'1"	77 <sup>3</sup> / <sub>8</sub> "	1413
AHS-6-20-14	6,000 lb.	20' / 12 <sup>5</sup> / <sub>16</sub> "	6 <sup>1</sup> / <sub>2</sub> "	8'7" to 14'1"	89 <sup>3</sup> / <sub>4</sub> "	1513
AHS-6-20-16	6,000 lb.	20' / 12 <sup>5</sup> / <sub>16</sub> "	6 <sup>1</sup> / <sub>2</sub> "	10'7" to 16'1"	89 <sup>3</sup> / <sub>4</sub> "	1532
AHS-8-10-12	8,000 lb.	10' / 8 <sup>1</sup> / <sub>8</sub> "	4"	7'7" to 12'1"	76 <sup>1</sup> / <sub>2</sub> "	933
AHS-8-10-14	8,000 lb.	10' / 8 <sup>1</sup> / <sub>8</sub> "	4"	8'6" to 14'	88 <sup>1</sup> / <sub>4</sub> "	1050
AHS-8-10-16	8,000 lb.	10' / 8 <sup>1</sup> / <sub>8</sub> "	4"	10'6" to 16'	88 <sup>1</sup> / <sub>4</sub> "	1121
AHS-8-15-7	8,000 lb.	15' / 10 <sup>1</sup> / <sub>8</sub> "	4"	5' to 7'	45 <sup>3</sup> / <sub>4</sub> "	804
AHS-8-15-9	8,000 lb.	15' / 10 <sup>1</sup> / <sub>8</sub> "	4"	6' to 9'	57 <sup>3</sup> / <sub>4</sub> "	905
AHS-8-15-10	8,000 lb.	15' / 10 <sup>1</sup> / <sub>8</sub> "	4"	6'6" to 10'	63 <sup>3</sup> / <sub>4</sub> "	960
AHS-8-15-12	8,000 lb.	15' / 10 <sup>1</sup> / <sub>8</sub> "	4"	7'7" to 12'1"	76 <sup>1</sup> / <sub>2</sub> "	1044
AHS-8-15-14	8,000 lb.	15' / 10 <sup>1</sup> / <sub>8</sub> "	4"	8'6" to 14'	88 <sup>1</sup> / <sub>4</sub> "	1132
AHS-8-15-16	8,000 lb.	15' / 10 <sup>1</sup> / <sub>8</sub> "	4"	10'6" to 16'	88 <sup>1</sup> / <sub>4</sub> "	1194
AHS-8-20-12	8,000 lb.	20' / 12 <sup>5</sup> / <sub>16</sub> "	6 <sup>1</sup> / <sub>2</sub> "	7'7" to 12'1"	76 <sup>1</sup> / <sub>2</sub> "	1406
AHS-8-20-14	8,000 lb.	20' / 12 <sup>5</sup> / <sub>16</sub> "	6 <sup>1</sup> / <sub>2</sub> "	8'6" to 14'	88 <sup>5</sup> / <sub>16</sub> "	1514
AHS-8-20-16	8,000 lb.	20' / 12 <sup>5</sup> / <sub>16</sub> "	6 <sup>1</sup> / <sub>2</sub> "	10'6" to 16'	88 <sup>1</sup> / <sub>4</sub> "	1582
AHS-10-15-10	10,000 lb.	15' / 12 <sup>1</sup> / <sub>8</sub> "	4"	6'6" to 10'	64 <sup>1</sup> / <sub>2</sub> "	1352

**ADJUSTABLE STEEL GANTRY CRANE OPTIONS (WHEN PURCHASED WITH GANTRY CRANE)**

AHS-2/4-TLC	TOTAL LOCKING CASTERS (2,000 & 4,000 LB. CAPACITY CRANES ONLY) (SET OF 4)
AHS-6/8-TLC	TOTAL LOCKING CASTERS (6,000 & 8,000 LB. CAPACITY CRANES ONLY) (SET OF 4)
AHS-2/4-V	8" x 2" V-GROOVE CASTERS FOR 2,000 & 4,000 LB. UNITS (SET OF 4)
AHS-6/8-V	8" x 3" V-GROOVE CASTERS FOR 6,000 & 8,000 LB. UNITS (SET OF 4)
AHS-KIT	(2) COME-A-LONG (2) CABLES FOR HEIGHT ADJUSTMENT (NOT FOR LIFTING)
AHS-STLO	STATIONARY LEG OPTION, set of (4) four (factory installed) NOT COMPATIBLE WITH AHS-10-15-10
AHS-STLO-RF	STATIONARY LEG OPTION, set of (4) four (field installed) NOT COMPATIBLE WITH AHS-10-15-10

USABLE DISTANCE BETWEEN UPRIGHTS IS OVERALL BEAM LENGTH MINUS 12"  
USABLE TROLLEY TRAVEL LENGTH IS OVERALL BEAM LENGTH MINUS 30"

*Note: All products should be inspected frequently to insure safe operation. Final testing and inspection is left to end user after final assembly has been completed. For further details see ASME B30.17.*

## Adjustable Steel Gantry Cranes - Knockdown

Adjustable Knockdown Steel Gantry Cranes are uniquely designed to be disassembled when not in use for compact storage and easier transportation / shipping from one job site to another. Facilitate easy mobility from one area to another with four (4) 8" swivel casters with four-position locks. 2K-4K models have glass filled nylon casters, 6K-8K models have phenolic casters, and 10K model has steel casters. Features quick setup design. Height is adjustable in 6" increments. Do not move units while loaded. Painted blue finish. Requires assistance from fork truck to set-up. Caster options are located on the bottom of page 202. Hoist and trolley can be ordered separately, see pages 210-214.

**Note: All products should be inspected frequently to insure safe operation. Final testing and inspection is left to end user after final assembly has been completed. For further details see ASME B30.17.**

MODEL NUMBER	UNIFORM CAPACITY	OVERALL I-BEAM LENGTH & HEIGHT	I-BEAM FLANGE WIDTH	UNDER I-BEAM USABLE HEIGHT	BASE WIDTH	WEIGHT (POUND)
AHSN-2-10-12	2,000 lb.	10' / 6"	4"	7'6" to 12'	79 <sup>3</sup> / <sub>4</sub> "	876
AHSN-2-10-14	2,000 lb.	10' / 6"	4"	8'6" to 14'	91 <sup>1</sup> / <sub>2</sub> "	952
AHSN-2-10-16	2,000 lb.	10' / 6"	4"	10'6" to 16'	91 <sup>1</sup> / <sub>2</sub> "	999
AHSN-2-15-7	2,000 lb.	15' / 6"	4"	5' to 7'	50"	740
AHSN-2-15-9	2,000 lb.	15' / 6"	4"	6' to 9'	61 <sup>7</sup> / <sub>8</sub> "	818
AHSN-2-15-10	2,000 lb.	15' / 6"	4"	6'6" to 10'	67 <sup>13</sup> / <sub>16</sub> "	855
AHSN-2-15-12	2,000 lb.	15' / 6"	4"	7'6" to 12'	79 <sup>3</sup> / <sub>4</sub> "	933
AHSN-2-15-14	2,000 lb.	15' / 6"	4"	8'6" to 14'	91 <sup>1</sup> / <sub>2</sub> "	1006
AHSN-2-15-16	2,000 lb.	15' / 6"	4"	10'6" to 16'	91 <sup>1</sup> / <sub>2</sub> "	1056
AHSN-2-20-12	2,000 lb.	20' / 10 <sup>1</sup> / <sub>8</sub> "	4"	7'6" to 12'	79 <sup>3</sup> / <sub>4</sub> "	1120
AHSN-2-20-14	2,000 lb.	20' / 10 <sup>1</sup> / <sub>8</sub> "	4"	8'6" to 14'	91 <sup>1</sup> / <sub>2</sub> "	1206
AHSN-2-20-16	2,000 lb.	20' / 10 <sup>1</sup> / <sub>8</sub> "	4"	10'6" to 16'	91 <sup>1</sup> / <sub>2</sub> "	1242
AHSN-4-10-12	4,000 lb.	10' / 8 <sup>1</sup> / <sub>8</sub> "	4"	7'6" to 12'	79 <sup>3</sup> / <sub>4</sub> "	909
AHSN-4-10-14	4,000 lb.	10' / 8 <sup>1</sup> / <sub>8</sub> "	4"	8'6" to 14'	91 <sup>1</sup> / <sub>2</sub> "	984
AHSN-4-10-16	4,000 lb.	10' / 8 <sup>1</sup> / <sub>8</sub> "	4"	10'6" to 16'	91 <sup>1</sup> / <sub>2</sub> "	1039
AHSN-4-15-7	4,000 lb.	15' / 8 <sup>1</sup> / <sub>8</sub> "	4"	5' to 7'	50"	786
AHSN-4-15-9	4,000 lb.	15' / 8 <sup>1</sup> / <sub>8</sub> "	4"	6' to 9'	61 <sup>7</sup> / <sub>8</sub> "	857
AHSN-4-15-10	4,000 lb.	15' / 8 <sup>1</sup> / <sub>8</sub> "	4"	6'6" to 10'	67 <sup>13</sup> / <sub>16</sub> "	908
AHSN-4-15-12	4,000 lb.	15' / 8 <sup>1</sup> / <sub>8</sub> "	4"	7'6" to 12'	79 <sup>3</sup> / <sub>4</sub> "	976
AHSN-4-15-14	4,000 lb.	15' / 8 <sup>1</sup> / <sub>8</sub> "	4"	8'6" to 14'	91 <sup>1</sup> / <sub>2</sub> "	1052
AHSN-4-15-16	4,000 lb.	15' / 8 <sup>1</sup> / <sub>8</sub> "	4"	10'6" to 16'	91 <sup>1</sup> / <sub>2</sub> "	1101
AHSN-4-20-12	4,000 lb.	20' / 12 <sup>3</sup> / <sub>16</sub> "	4"	7'6" to 12'	79 <sup>3</sup> / <sub>4</sub> "	1132
AHSN-4-20-14	4,000 lb.	20' / 12 <sup>3</sup> / <sub>16</sub> "	4"	8'6" to 14'	91 <sup>1</sup> / <sub>2</sub> "	1212
AHSN-4-20-16	4,000 lb.	20' / 12 <sup>3</sup> / <sub>16</sub> "	4"	10'6" to 16'	91 <sup>1</sup> / <sub>2</sub> "	1260
AHSN-6-10-12	6,000 lb.	10' / 8 <sup>1</sup> / <sub>8</sub> "	4"	7'7" to 12'1"	76 <sup>1</sup> / <sub>4</sub> "	991
AHSN-6-10-14	6,000 lb.	10' / 8 <sup>1</sup> / <sub>8</sub> "	4"	8'7" to 14'1"	88"	1051
AHSN-6-10-16	6,000 lb.	10' / 8 <sup>1</sup> / <sub>8</sub> "	4"	10'7" to 16'1"	88"	1109
AHSN-6-15-7	6,000 lb.	15' / 10 <sup>1</sup> / <sub>8</sub> "	4"	5'1" to 7'1"	46 <sup>1</sup> / <sub>2</sub> "	864
AHSN-6-15-9	6,000 lb.	15' / 10 <sup>1</sup> / <sub>8</sub> "	4"	6'1" to 9'1"	58 <sup>3</sup> / <sub>8</sub> "	934
AHSN-6-15-10	6,000 lb.	15' / 10 <sup>1</sup> / <sub>8</sub> "	4"	6'7" to 10'1"	64 <sup>5</sup> / <sub>16</sub> "	980
AHSN-6-15-12	6,000 lb.	15' / 10 <sup>1</sup> / <sub>8</sub> "	4"	7'7" to 12'1"	76 <sup>1</sup> / <sub>4</sub> "	1054
AHSN-6-15-14	6,000 lb.	15' / 10 <sup>1</sup> / <sub>8</sub> "	4"	8'7" to 14'1"	88"	1132
AHSN-6-15-16	6,000 lb.	15' / 10 <sup>1</sup> / <sub>8</sub> "	4"	10'7" to 16'1"	88"	1182
AHSN-6-20-12	6,000 lb.	20' / 12 <sup>5</sup> / <sub>16</sub> "	6 <sup>1</sup> / <sub>2</sub> "	7'7" to 12'1"	76 <sup>1</sup> / <sub>4</sub> "	1449
AHSN-6-20-14	6,000 lb.	20' / 12 <sup>5</sup> / <sub>16</sub> "	6 <sup>1</sup> / <sub>2</sub> "	8'7" to 14'1"	88"	1521
AHSN-6-20-16	6,000 lb.	20' / 12 <sup>5</sup> / <sub>16</sub> "	6 <sup>1</sup> / <sub>2</sub> "	10'7" to 16'1"	88"	1569
AHSN-8-10-12	8,000 lb.	10' / 8 <sup>1</sup> / <sub>8</sub> "	4"	7'7" to 12'1"	76 <sup>1</sup> / <sub>4</sub> "	979
AHSN-8-10-14	8,000 lb.	10' / 8 <sup>1</sup> / <sub>8</sub> "	4"	8'7" to 14'1"	88"	1051
AHSN-8-10-16	8,000 lb.	10' / 8 <sup>1</sup> / <sub>8</sub> "	4"	10'7" to 16'1"	88"	1107
AHSN-8-15-7	8,000 lb.	15' / 10 <sup>1</sup> / <sub>8</sub> "	4"	5'1" to 7'1"	46 <sup>1</sup> / <sub>2</sub> "	862
AHSN-8-15-9	8,000 lb.	15' / 10 <sup>1</sup> / <sub>8</sub> "	4"	6'1" to 9'1"	58 <sup>3</sup> / <sub>8</sub> "	940
AHSN-8-15-10	8,000 lb.	15' / 10 <sup>1</sup> / <sub>8</sub> "	4"	6'7" to 10'1"	64 <sup>5</sup> / <sub>16</sub> "	974
AHSN-8-15-12	8,000 lb.	15' / 10 <sup>1</sup> / <sub>8</sub> "	4"	7'7" to 12'1"	76 <sup>1</sup> / <sub>4</sub> "	1050
AHSN-8-15-14	8,000 lb.	15' / 10 <sup>1</sup> / <sub>8</sub> "	4"	8'7" to 14'1"	88"	1142
AHSN-8-15-16	8,000 lb.	15' / 10 <sup>1</sup> / <sub>8</sub> "	4"	10'7" to 16'1"	88"	1182
AHSN-8-20-12	8,000 lb.	20' / 12 <sup>5</sup> / <sub>16</sub> "	6 <sup>1</sup> / <sub>2</sub> "	7'7" to 12'1"	76 <sup>1</sup> / <sub>4</sub> "	1445
AHSN-8-20-14	8,000 lb.	20' / 12 <sup>5</sup> / <sub>16</sub> "	6 <sup>1</sup> / <sub>2</sub> "	8'7" to 14'1"	88"	1523
AHSN-8-20-16	8,000 lb.	20' / 12 <sup>5</sup> / <sub>16</sub> "	6 <sup>1</sup> / <sub>2</sub> "	10'7" to 16'1"	88"	1577
AHSN-10-15-10	10,000 lb.	15' / 12 <sup>3</sup> / <sub>16</sub> "	4"	6'7" to 10'1"	64 <sup>5</sup> / <sub>16</sub> "	1355

ADJUSTABLE STEEL GANTRY CRANE - KNOCKDOWN OPTIONS (WHEN PURCHASED WITH GANTRY CRANE)	
AHSN-KIT	BEAM HEIGHT ADJUSTMENT KIT (2) weldment assemblies, (2) slings
AHS-STLO	STATIONARY LEG OPTION, set of (4) four (field installed) NOT COMPATIBLE WITH AHSN-10-15-10
AHS-STLO-RF	STATIONARY LEG OPTION, set of (4) four (field installed) NOT COMPATIBLE WITH AHSN-10-15-10

USABLE DISTANCE BETWEEN UPRIGHTS IS OVERALL BEAM LENGTH MINUS 12"  
USABLE TROLLEY TRAVEL LENGTH IS OVERALL BEAM LENGTH MINUS 30"

**New**



ADJUSTABLE STEEL GANTRY CRANES - KNOCKDOWN series AHSN



HOIST & TROLLEY SOLD SEPARATELY. SEE PAGE F10 THRU F14



KNOCKDOWN INDIVIDUAL COMPONENTS CAN BE STORED WHEN CRANE IS NOT NEEDED



KNOCKDOWN DESIGN ALLOWS FOR COMPLETE CRANE DISASSEMBLY FOR LOWER FREIGHT AND TRANSPORTATION COSTS



FIXED HEIGHT STEEL GANTRY CRANES series FHS

YouTube

**New**  
48 Hours to Ship

*Note: All products should be inspected frequently to insure safe operation. Final testing and inspection is left to end user after final assembly has been completed. For further details see ASME B30.17.*



FIXED HEIGHT STEEL GANTRY CRANES - KNOCKDOWN series FHSN

**New**



KNOCKDOWN DESIGN ALLOWS FOR COMPLETE CRANE DISASSEMBLY FOR LOWER FREIGHT AND TRANSPORTATION COSTS

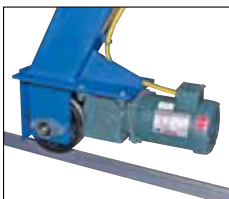

FACTORY INSTALLED OPTION ONLY

## Fixed Steel Gantry Cranes

Industrial Steel Gantry Cranes are designed for positioning materials along the beam's length. Solid steel construction will provide years of service. Facilitate easy mobility from one area to another with four (4) 8" swivel casters with four-position locks. 2K-4K models have glass filled nylon casters, 6K-8K models have phenolic casters, and 10K model has steel casters. More economical and flexible than permanent cranes. Features quick setup design. Designed for semi-permanent or permanent applications. Requires assistance from fork truck to set-up. Do not move units while loaded. Painted blue finish. Caster options are located on the bottom of page 202. Hoist and trolley can be ordered separately, see pages 210-214.

MODEL NUMBER	UNIFORM CAPACITY	OVERALL I-BEAM LENGTH / HEIGHT	I-BEAM FLANGE WIDTH	UNDER I-BEAM TO GROUND	BASE WIDTH	WEIGHT (POUND)
FHS-50	500 lb.	8' / 6"	4"	5'9"	46½"	512
FHS-2-10	2,000 lb.	10' / 6"	4"	10'	64½"	739
FHS-2-15	2,000 lb.	15' / 6"	4"	10'	64½"	801
FHS-2-20	2,000 lb.	20' / 10½"	4"	10'	64½"	994
FHS-4-10	4,000 lb.	10' / 8½"	4"	10'	64½"	771
FHS-4-15	4,000 lb.	15' / 8½"	4"	10'	64½"	846
FHS-4-20	4,000 lb.	20' / 12¾"	4"	10'	64½"	1006
FHS-6-10	6,000 lb.	10' / 8½"	4"	10'1"	65½"	775
FHS-6-15	6,000 lb.	15' / 10½"	4"	10'1"	65½"	963
FHS-6-20	6,000 lb.	20' / 12¾"	6½"	10'1"	65½"	1355
FHS-8-10	8,000 lb.	10' / 8½"	4"	10'1"	64¼"	855
FHS-8-15	8,000 lb.	15' / 10½"	4"	10'1"	64¼"	956
FHS-8-20	8,000 lb.	20' / 12¾"	6½"	10'1"	64¼"	1385
FHS-10-10	10,000 lb.	10' / 10½"	4"	10'	64½"	1093
FHS-10-15	10,000 lb.	15' / 12¾"	4"	10'	64½"	1428

### FIXED STEEL GANTRY CRANE OPTIONS (WHEN PURCHASED WITH GANTRY CRANE)

FHS-STLO	STATIONARY LEG OPTION, set of (4) four (factory installed)
FHS-STLO-RF	STATIONARY LEG OPTION, set of (4) four (field installed)

## Fixed Height Steel Gantry Cranes - Knockdown

Fixed Height Knockdown Industrial Steel Gantry Cranes are uniquely designed to be disassembled when not in use for compact storage and easier transportation / shipping from one job site to another. Facilitate easy mobility from one area to another with four (4) 8" swivel casters with four-position locks. 2K-4K models have glass filled nylon casters, 6K-8K models have phenolic casters, and 10K model has steel casters. Features quick setup design. Do not move units while loaded. Painted blue finish. Designed for semi-permanent or permanent applications. Requires assistance from fork truck to set-up. Hoist and trolley can be ordered separately, see pages 210-214.

MODEL NUMBER	UNIFORM CAPACITY	OVERALL I-BEAM LENGTH / HEIGHT	I-BEAM FLANGE WIDTH	UNDER I-BEAM TO GROUND	BASE WIDTH	WEIGHT (POUND)
FHSN-50	500 lb.	8' / 6"	4"	5'9"	46½"	612
FHSN-2-10	2,000 lb.	10' / 6"	4"	10'	64½"	797
FHSN-2-15	2,000 lb.	15' / 6"	4"	10'	64½"	856
FHSN-2-20	2,000 lb.	20' / 10"	4"	10'	64½"	1045
FHSN-4-10	4,000 lb.	10' / 8"	4"	10'	64½"	829
FHSN-4-15	4,000 lb.	15' / 8"	4"	10'	64½"	905
FHSN-4-20	4,000 lb.	20' / 12"	4"	10'	64½"	1058
FHSN-6-10	6,000 lb.	10' / 8"	4"	10'	64½"	897
FHSN-6-15	6,000 lb.	15' / 10"	4"	10'	64½"	980
FHSN-6-20	6,000 lb.	20' / 12"	6½"	10'	64½"	1367
FHSN-8-10	8,000 lb.	10' / 8"	4"	10'	64½"	897
FHSN-8-15	8,000 lb.	15' / 10"	4"	10'	64½"	979
FHSN-8-20	8,000 lb.	20' / 12"	6½"	10'	64½"	1366
FHSN-10-10	10,000 lb.	10' / 10"	4"	10'	64½"	1107
FHSN-10-15	10,000 lb.	15' / 12"	4"	10'	64½"	1275

### FIXED STEEL GANTRY CRANE - KNOCKDOWN OPTIONS

FHS-STLO	STATIONARY LEG OPTION, set of (4) four (factory installed)
FHS-STLO-RF	STATIONARY LEG OPTION, set of (4) four (field installed)

## Steel Gantry Crane Power Traction Drive Options

Power Traction Drive Options for a gantry cranes are ideal for industrial manufacturing environments. The power traction drive allows the gantry crane to be moved to a desired position without need of extra personnel. The unit is maneuvered by a three (3) button push button control for precise movements, while being driven by 460V, 3 phase power. Do not move units while loaded.

MODEL NUMBER	DESCRIPTION
GPTD-2	2,000 TO 4,000 LB. UNIFORM CAPACITY/STD. WITH 3 BUTTON HAND CONTROL
GPTD-4	6,000 TO 8,000 LB. UNIFORM CAPACITY/STD. WITH 3 BUTTON HAND CONTROL
V-TRACK	10 FOOT SECTION OF V-GROOVE TRACK (ONE SIDE ONLY)

ADDITIONAL BUTTONS ON HAND CONTROL FOR HOIST & TROLLEY AVAILABLE, CONTACT FACTORY

## Adjustable Height Aluminum Gantry Cranes

Adjustable Height Aluminum Gantry Cranes combine lightweight and rigid construction into one unit. The all aluminum construction of this gantry crane makes it corrosion resistant and perfect for outdoor use. The lightweight I-beam allows height adjustment without the need of a hoist or fork truck. Features quick setup design. Included are two (2) straps, allowing transport of the gantry crane in one neat package. Facilitate easy mobility from one area to another with four (4) 8" swivel casters with four position locks. 2K-4K models have glass filled nylon casters and 6K models have phenolic casters. Height is adjustable in 6" increments. Do not move units while loaded. Hoist and trolley can be ordered separately, see pages 210-214.



2,000 & 4,000 LB. UNITS  
SHIP KNOCK-DOWN



2,000 & 4,000 LB. UNITS

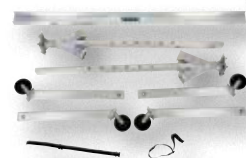

KNOCKDOWN DESIGN FOR EASY  
TRANSPORTATION ONTO ROOFS OR  
THROUGH DOORWAYS

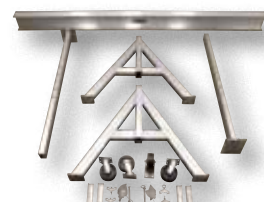

6,000 LB. UNITS



ADJUSTABLE  
HEIGHT



OPTIONAL TOTAL  
LOCKING CASTERS  
model AHA-2/4-TLC

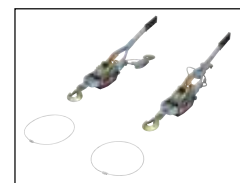

COME-A-LONG  
model AHA-KIT

*Note: All products should be inspected frequently to insure safe operation. Final testing and inspection is left to end user after final assembly has been completed. For further details see ASME B30.17.*

MODEL NUMBER	UNIFORM CAPACITY	OVERALL I-BEAM LENGTH / HEIGHT	I-BEAM FLANGE WIDTH	UNDER I-BEAM RANGE	BASE WIDTH	WEIGHT (POUND)
AHA-2-8-8	2,000 lb.	8' / 6"	3 <sup>5</sup> / <sub>16</sub> "	5'8" to 8'2"	53 <sup>3</sup> / <sub>4</sub> "	234
AHA-2-8-10	2,000 lb.	8' / 6"	3 <sup>5</sup> / <sub>16</sub> "	7'8" to 10'2"	53 <sup>3</sup> / <sub>4</sub> "	239
AHA-2-8-12	2,000 lb.	8' / 6"	3 <sup>5</sup> / <sub>16</sub> "	9'6" to 12'	53 <sup>3</sup> / <sub>4</sub> "	246
AHA-2-10-8	2,000 lb.	10' / 6"	3 <sup>5</sup> / <sub>16</sub> "	5'8" to 8'2"	53 <sup>3</sup> / <sub>4</sub> "	231
AHA-2-10-10	2,000 lb.	10' / 6"	3 <sup>5</sup> / <sub>16</sub> "	7'8" to 10'2"	53 <sup>3</sup> / <sub>4</sub> "	252
AHA-2-10-12	2,000 lb.	10' / 6"	3 <sup>5</sup> / <sub>16</sub> "	9'6" to 12'	53 <sup>3</sup> / <sub>4</sub> "	261
AHA-2-12-8	2,000 lb.	12' / 8"	4"	5'8" to 8'2"	53 <sup>13</sup> / <sub>16</sub> "	266
AHA-2-12-10	2,000 lb.	12' / 8"	4"	7'8" to 10'2"	53 <sup>13</sup> / <sub>16</sub> "	274
AHA-2-12-12	2,000 lb.	12' / 8"	4"	9'6" to 12'	53 <sup>13</sup> / <sub>16</sub> "	286
AHA-2-15-8	2,000 lb.	15' / 8"	4 <sup>3</sup> / <sub>16</sub> "	5'8" to 8'2"	53 <sup>13</sup> / <sub>16</sub> "	320
AHA-2-15-10	2,000 lb.	15' / 8"	4 <sup>3</sup> / <sub>16</sub> "	7'8" to 10'2"	53 <sup>13</sup> / <sub>16</sub> "	364
AHA-2-15-12	2,000 lb.	15' / 8"	4 <sup>3</sup> / <sub>16</sub> "	9'6" to 12'	53 <sup>13</sup> / <sub>16</sub> "	371
AHA-4-8-8	4,000 lb.	8' / 8"	4"	5'8" to 8'2"	53 <sup>15</sup> / <sub>16</sub> "	276
AHA-4-8-10	4,000 lb.	8' / 8"	4"	7'8" to 10'2"	53 <sup>15</sup> / <sub>16</sub> "	292
AHA-4-8-12	4,000 lb.	8' / 8"	4"	9'6" to 12'	53 <sup>15</sup> / <sub>16</sub> "	301
AHA-4-10-8	4,000 lb.	10' / 8"	4 <sup>3</sup> / <sub>16</sub> "	5'8" to 8'2"	53 <sup>15</sup> / <sub>16</sub> "	298
AHA-4-10-10	4,000 lb.	10' / 8"	4 <sup>3</sup> / <sub>16</sub> "	7'8" to 10'2"	53 <sup>15</sup> / <sub>16</sub> "	307
AHA-4-10-12	4,000 lb.	10' / 8"	4 <sup>3</sup> / <sub>16</sub> "	9'6" to 12'	53 <sup>15</sup> / <sub>16</sub> "	349
AHA-4-12-8	4,000 lb.	12' / 8"	4 <sup>3</sup> / <sub>16</sub> "	5'8" to 8'2"	53 <sup>15</sup> / <sub>16</sub> "	302
AHA-4-12-10	4,000 lb.	12' / 8"	4 <sup>3</sup> / <sub>16</sub> "	7'8" to 10'2"	53 <sup>15</sup> / <sub>16</sub> "	325
AHA-4-12-12	4,000 lb.	12' / 8"	4 <sup>3</sup> / <sub>16</sub> "	9'6" to 12'	53 <sup>15</sup> / <sub>16</sub> "	350
AHA-4-15-8	4,000 lb.	15' / 10"	4 <sup>11</sup> / <sub>16</sub> "	5'8" to 8'2"	53 <sup>15</sup> / <sub>16</sub> "	354
AHA-4-15-10	4,000 lb.	15' / 10"	4 <sup>11</sup> / <sub>16</sub> "	7'8" to 10'2"	53 <sup>15</sup> / <sub>16</sub> "	370
AHA-4-15-12	4,000 lb.	15' / 10"	4 <sup>11</sup> / <sub>16</sub> "	9'6" to 12'	53 <sup>15</sup> / <sub>16</sub> "	394
AHA-6-8-8	6,000 lb.	8' / 10"	4 <sup>11</sup> / <sub>16</sub> "	6'2" to 8'2"	64 <sup>11</sup> / <sub>16</sub> "	470
AHA-6-8-10	6,000 lb.	8' / 10"	4 <sup>11</sup> / <sub>16</sub> "	8'2" to 10'2"	64 <sup>11</sup> / <sub>16</sub> "	488
AHA-6-8-12	6,000 lb.	8' / 10"	4 <sup>11</sup> / <sub>16</sub> "	10'2" to 12'2"	64 <sup>11</sup> / <sub>16</sub> "	506
AHA-6-10-8	6,000 lb.	10' / 10"	4 <sup>11</sup> / <sub>16</sub> "	6'2" to 8'2"	64 <sup>11</sup> / <sub>16</sub> "	554
AHA-6-10-10	6,000 lb.	10' / 10"	4 <sup>11</sup> / <sub>16</sub> "	8'2" to 10'2"	64 <sup>11</sup> / <sub>16</sub> "	572
AHA-6-10-12	6,000 lb.	10' / 10"	4 <sup>11</sup> / <sub>16</sub> "	10'2" to 12'2"	64 <sup>11</sup> / <sub>16</sub> "	534
AHA-6-12-8	6,000 lb.	12' / 12"	7"	6'2" to 8'2"	64 <sup>11</sup> / <sub>16</sub> "	568
AHA-6-12-10	6,000 lb.	12' / 12"	7"	8'2" to 10'2"	64 <sup>11</sup> / <sub>16</sub> "	589
AHA-6-12-12	6,000 lb.	12' / 12"	7"	10'2" to 12'2"	64 <sup>11</sup> / <sub>16</sub> "	607
AHA-6-15-8	6,000 lb.	15' / 12"	7"	6'2" to 8'2"	64 <sup>11</sup> / <sub>16</sub> "	630
AHA-6-15-10	6,000 lb.	15' / 12"	7"	8'2" to 10'2"	64 <sup>11</sup> / <sub>16</sub> "	642
AHA-6-15-12	6,000 lb.	15' / 12"	7"	10'2" to 12'2"	64 <sup>11</sup> / <sub>16</sub> "	648

USABLE DISTANCE BETWEEN UPRIGHTS IS OVERALL I-BEAM LENGTH MINUS 18"  
USABLE TROLLEY TRAVEL LENGTH IS OVERALL I-BEAM LENGTH MINUS 23<sup>3</sup>/<sub>4</sub>"

## Aluminum Gantry Crane Options

ALUMINUM GANTRY CRANE OPTIONS (WHEN PURCHASED WITH GANTRY CRANE)	
MODEL NUMBER	DESCRIPTION
AHA-2/4-TLC	TOTAL LOCKING CASTERS (2,000 & 4,000 LB. UNIFORM CAPACITY CRANES ONLY) (SET OF 4)
AHA-PNU-RF	RETROFIT FOUR-WAY LOCK PNEUMATIC CASTERS (1,500 LB. UNIFORM CAPACITY) (SET OF 4)
AHA-2/4-V	8" x 2" V-GROOVE WHEELS (2,000 & 4,000 LB. UNITS) (SET OF 4)
AHA-2/4-V4	8" x 2" V-GROOVE WHEELS (2,000 & 4,000 LB. UNITS) (W/4-POSITION LOCK) (SET OF 4)
AHA-KIT	(2) COME-A-LONG (2) CABLES FOR HEIGHT ADJUSTMENT (NOT FOR LIFTING)
AHA-STLO	STATIONARY LEG OPTION, set of (4) four (factory installed)
AHA-STLO-RF	STATIONARY LEG OPTION, set of (4) four (field installed)



**PNEUMATIC CASTERS**  
model AHA-PNU

*Note: All products should be inspected frequently to insure safe operation. Final testing and inspection is left to end user after final assembly has been completed. For further details see ASME B30.17.*

## Adjustable Height Aluminum Gantry Cranes with Pneumatic Casters

Adjustable Height Aluminum Gantry Cranes are ideal for the manufacturing and maintenance facilities. The aluminum construction is lightweight, yet strong for long lasting durability through the harshest of environments. The pneumatic casters allow the user to quietly move the crane from workstation to workstation and smoothly roll over rough surfaces, while not marring. The four-way locking pneumatic casters permit the user to place the crane in preferred transporting and stationary positions. Do not move units while loaded. Uniform capacity is 1,500 pounds.

MODEL NUMBER	OVERALL I-BEAM LENGTH / HEIGHT	I-BEAM FLANGE WIDTH	UNDER I-BEAM RANGE	BASE WIDTH	WEIGHT (POUND)
AHA-15-8-8-PNU	8' / 6"	3 <sup>5</sup> / <sub>16</sub> "	6'2" to 8'8"	53 <sup>3</sup> / <sub>4</sub> "	254
AHA-15-8-10-PNU	8' / 6"	3 <sup>5</sup> / <sub>16</sub> "	8'2" to 10'8"	53 <sup>3</sup> / <sub>4</sub> "	269
AHA-15-8-12-PNU	8' / 6"	3 <sup>5</sup> / <sub>16</sub> "	10' to 12'6"	53 <sup>3</sup> / <sub>4</sub> "	282
AHA-15-10-8-PNU	10' / 6"	3 <sup>5</sup> / <sub>16</sub> "	6'2" to 8'8"	53 <sup>3</sup> / <sub>4</sub> "	275
AHA-15-10-10-PNU	10' / 6"	3 <sup>5</sup> / <sub>16</sub> "	8'2" to 10'8"	53 <sup>3</sup> / <sub>4</sub> "	284
AHA-15-10-12-PNU	10' / 6"	3 <sup>5</sup> / <sub>16</sub> "	10' to 12'6"	53 <sup>3</sup> / <sub>4</sub> "	291
AHA-15-12-8-PNU	12' / 8"	4"	6'2" to 8'8"	53 <sup>3</sup> / <sub>4</sub> "	287
AHA-15-12-10-PNU	12' / 8"	4"	8'2" to 10'8"	53 <sup>3</sup> / <sub>4</sub> "	301
AHA-15-12-12-PNU	12' / 8"	4"	10' to 12'6"	53 <sup>3</sup> / <sub>4</sub> "	315
AHA-15-15-8-PNU	15' / 8"	4 <sup>3</sup> / <sub>16</sub> "	6'2" to 8'8"	53 <sup>3</sup> / <sub>4</sub> "	348
AHA-15-15-10-PNU	15' / 8"	4 <sup>3</sup> / <sub>16</sub> "	8'2" to 10'8"	53 <sup>3</sup> / <sub>4</sub> "	359
AHA-15-15-12-PNU	15' / 8"	4 <sup>3</sup> / <sub>16</sub> "	10' to 12'6"	53 <sup>3</sup> / <sub>4</sub> "	368

USABLE DISTANCE BETWEEN UPRIGHTS IS OVERALL I-BEAM LENGTH MINUS 18"  
USABLE TROLLEY TRAVEL LENGTH IS OVERALL I-BEAM LENGTH MINUS 23<sup>3</sup>/<sub>4</sub>"



## Fixed Height Aluminum Gantry Cranes

Fixed Height Aluminum Gantry Cranes are ideal for variety of industries including maintenance and production. The aluminum design is easily manageable and can be simply assembled for immediate use. A fixed height is perfect for working in a permanent or semi-permanent environment where the surrounding seldom change. Casters provide a smooth way to transfer units when unloaded and if changing locations is needed. Four (4) 8" swivel casters with four position locks. 2K-4K models have glass filled nylon casters and 6K models have phenolic casters. A strong construction allows for long lasting strength through the harshest of environments.

MODEL NUMBER	UNIFORM CAPACITY	OVERALL I-BEAM LENGTH / HEIGHT	I-BEAM FLANGE WIDTH	UNDER I-BEAM RANGE	BASE WIDTH	WEIGHT (POUND)
FHA-2-8-10	2,000 lb.	96" / 6"	3 <sup>5</sup> / <sub>16</sub> "	120"	53 <sup>3</sup> / <sub>4</sub> "	331
FHA-2-10-10	2,000 lb.	120" / 6"	3 <sup>5</sup> / <sub>16</sub> "	120"	53 <sup>3</sup> / <sub>4</sub> "	333
FHA-2-12-10	2,000 lb.	144" / 8"	4"	120"	53 <sup>3</sup> / <sub>4</sub> "	355
FHA-2-15-10	2,000 lb.	180" / 8"	4 <sup>3</sup> / <sub>16</sub> "	120"	53 <sup>3</sup> / <sub>4</sub> "	445
FHA-4-8-10	4,000 lb.	96" / 8"	4"	120"	53 <sup>5</sup> / <sub>16</sub> "	390
FHA-4-10-10	4,000 lb.	120" / 8"	4 <sup>3</sup> / <sub>16</sub> "	120"	53 <sup>5</sup> / <sub>16</sub> "	390
FHA-4-12-10	4,000 lb.	144" / 8"	4 <sup>3</sup> / <sub>16</sub> "	120"	53 <sup>5</sup> / <sub>16</sub> "	406
FHA-4-15-10	4,000 lb.	180" / 10"	4 <sup>11</sup> / <sub>16</sub> "	120"	53 <sup>5</sup> / <sub>16</sub> "	442
FHA-6-8-10	6,000 lb.	96" / 10"	4 <sup>11</sup> / <sub>16</sub> "	120"	64 <sup>11</sup> / <sub>16</sub> "	639
FHA-6-10-10	6,000 lb.	120" / 10"	4 <sup>11</sup> / <sub>16</sub> "	120"	64 <sup>11</sup> / <sub>16</sub> "	734
FHA-6-12-10	6,000 lb.	144" / 12"	7"	120"	64 <sup>11</sup> / <sub>16</sub> "	993
FHA-6-15-10	6,000 lb.	180" / 12"	7"	120"	64 <sup>11</sup> / <sub>16</sub> "	994

### FIXED HEIGHT ALUMINUM GANTRY CRANE OPTIONS

FHA-STLO	STATIONARY LEG OPTION, set of (4) four (factory installed)
FHA-STLO-RF	STATIONARY LEG OPTION, set of (4) four (field installed)

USABLE DISTANCE BETWEEN UPRIGHTS IS OVERALL I-BEAM LENGTH MINUS 15-7/8"  
USABLE TROLLEY TRAVEL LENGTH IS OVERALL I-BEAM LENGTH MINUS 23-3/4"



## Self-Supporting Bridge Cranes

The system is composed of modular units so that the components can be reused when the layout is changed. The system does not require any electrical power. The overall height is 14 feet. Festoon for electric hoist is not included. Contact factory for pricing.



MODEL NUMBER	RUNWAY LENGTH	BRIDGE LENGTH	UNIFORM CAPACITY OF CRANES WEIGHT	
	(FEET)	(FEET)	500 LB.	1,000 LB.
B1020-(capacity)	20	10	1575	1890
B1030-(capacity)	30	10	2289	2467

## Work Area Portable Steel Gantry Cranes

Designed to maximize material handling requirements in light-duty lifting applications. Lightweight fixed height design allows for easy mobility. Includes (4) 5" x 2" poly-on-steel swivel casters with brake. Overall I-beam length is 79¾" with a usable length of 69¾" (FPG-20 usable length of 67¾"). Do not move units while loaded. Steel construction with blue baked-in powder-coated toughness. Bolt together installation. Hoist and trolley can be ordered separately, see pages 210-214.

MODEL NUMBER	UNDER I-BEAM TO GROUND	I-BEAM FLANGE WIDTH x HEIGHT	BASE WIDTH	STRADDLE LENGTH	UNIFORM CAPACITY	WEIGHT (POUND)
FPG-3	90"	2 <sup>11</sup> / <sub>16</sub> " x 4"	47¾"	69"	300 lb.	280
FPG-6	90"	2 <sup>11</sup> / <sub>16</sub> " x 4"	47¾"	69"	600 lb.	304
FPG-10	90"	2 <sup>11</sup> / <sub>16</sub> " x 4"	47¾"	68"	1,000 lb.	372
FPG-20	90"	2 <sup>11</sup> / <sub>16</sub> " x 4"	47¾"	67"	2,000 lb.	374



## Mini Overhead Cantilever Jibs

Utilize this unique jib in work cells and work areas. Unique fixed-height design allows for the 39¾" long outriggers to be mounted underneath a work bench. Easily lift product from cart to workbench. Straddle width is 47¾" (ID). I-beam usable length is 54". Hoist and trolley can be ordered separately, see pages 210-214. Steel construction with painted blue finish.

MODEL NUMBER	UNDER I-BEAM TO GROUND	OVERALL HEIGHT	I-BEAM FLANGE WIDTH x HEIGHT	UNIFORM CAPACITY	WEIGHT (POUND)
CJIB-3	84"	106 <sup>11</sup> / <sub>16</sub> "	2 <sup>11</sup> / <sub>16</sub> " x 4"	300 lb.	318
CJIB-6	84"	106 <sup>11</sup> / <sub>16</sub> "	2 <sup>11</sup> / <sub>16</sub> " x 4"	600 lb.	327
CJIB-10	78½"	103 <sup>11</sup> / <sub>16</sub> "	4" x 6"	1,000 lb.	496
CJIB-20	78½"	103 <sup>11</sup> / <sub>16</sub> "	4" x 6"	2,000 lb.	512



## Extra Travel Tri-Post Jibs

These unique jibs were designed for use in workstations. Place over the top of your workbench. Extra travel fixed-height I-beam overhangs workbench to allow lifting of products from cart to bench. I-Beam flange width is 2-11/16" and the height is 4". Usable I-beam length is 79¾". Hoist and trolley can be ordered separately, see pages 210-214. Steel construction with painted blue finish.

MODEL NUMBER	UNDER I-BEAM TO GROUND	OVERALL HEIGHT	OVERALL LENGTH	STRADDLE WIDTH (ID)	UNIFORM CAPACITY	WEIGHT (POUND)
TJIB-3	76½"	83"	85¼"	41½"	300 lb.	238
TJIB-6	76½"	83"	85¼"	41½"	600 lb.	248
TJIB-10	76"	83"	85½"	41"	1,000 lb.	285
TJIB-20	76"	83½"	85¾"	40¼"	2,000 lb.	321



## Floor Mounted Jibs

These fixed height Floor Mounted Jibs adapt well to many applications. Full 360° rotation allows personnel to completely utilize their workstation. Solid steel construction with blue finish assists workers in lifting awkward material. The overall I-beam length is 80". Requires reinforced concrete pad for installation. Hoist and trolley can be ordered separately, see pages 210-214.

MODEL NUMBER	UNDER I-BEAM FLOOR	USABLE I-BEAM LENGTH	I-BEAM FLANGE WIDTH x HEIGHT	OVERALL HEIGHT	UNIFORM CAPACITY	WEIGHT (POUND)
JIB-FM-3	99¼"	69¾"	2 <sup>11</sup> / <sub>16</sub> " x 4"	103¼"	300 lb.	428
JIB-FM-6	99¼"	69¾"	4" x 6"	105¼"	600 lb.	458
JIB-FM-10	99½"	67¾"	4" x 6"	105½"	1,000 lb.	610
JIB-FM-20	99½"	67¾"	4" x 10 <sup>1</sup> / <sub>8</sub> "	109 <sup>5</sup> / <sub>8</sub> "	2,000 lb.	651
JIB-FM-40	99¼"	66 <sup>1</sup> / <sub>8</sub> "	6½" x 12¼"	111½"	4,000 lb.	783



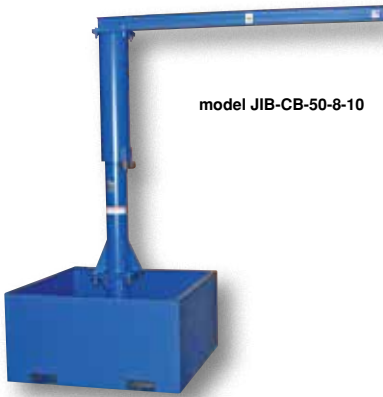

model JIB-CB-50-8-10

18"H base requires (41) 60 lb. bags of Sakrete mix

36"H base requires (82) 60 lb. bags of Sakrete mix



model JIB-CB-18-B

### Portable Jib Cranes with optional counterbalance base

Unique design allows for easy transportation of jib crane with a fork truck. Empty base models include instructions for proper filling with concrete. Base measures 42-3/16"W x 42-3/16"D x 18" or 36"H and includes built-in fork tubes. Fork tubes are 7 5/8"W x 2 5/8"H usable on 24" fork centers. Fixed length I-beam will pivot 360° for complete access. Under I-beam clearance is 10'. Upright vertical column bolts to base. Steel construction with blue painted finish. Units ship knocked down. Unit not for use as a fork truck attachment.

MODEL NUMBER	UNIFORM CAPACITY	I-BEAM LENGTH/HEIGHT	I-BEAM FLANGE WIDTH	BASE HEIGHT	WEIGHT (POUND)
<b>PORTABLE JIB WITH EMPTY BASE</b>					
JIB-CB-25-8-10	250 lb.	96" / 6"	4"	18"	981
JIB-CB-25-10-10	250 lb.	120" / 6"	4"	18"	985
JIB-CB-50-8-10	500 lb.	96" / 6"	4"	18"	982
JIB-CB-50-10-10	500 lb.	120" / 10 1/8"	4"	36"	1302
JIB-CB-100-8-10	1000 lb.	96" / 10 1/8"	4"	36"	1193
<b>PORTABLE JIB WITH CONCRETE FILLED BASE</b>					
JIB-CB-25-8-10-BC	250 lb.	96" / 6"	4"	18"	3443
JIB-CB-25-10-10-BC	250 lb.	120" / 6"	4"	18"	3192
JIB-CB-50-8-10-BC	500 lb.	96" / 6"	4"	18"	3448
JIB-CB-50-10-10-BC	500 lb.	120" / 10 1/8"	4"	36"	5749
JIB-CB-100-8-10-BC	1000 lb.	96" / 10 1/8"	4"	36"	5715
<b>OPTIONAL BASE - EMPTY</b>					
JIB-CB-18-B	ADDITIONAL STEEL BASE 18" HIGH - EMPTY				405
JIB-CB-36-B	ADDITIONAL STEEL BASE 36" HIGH - EMPTY				617
<b>OPTIONAL BASE WITH CONCRETE</b>					
JIB-CB-18-BC	ADDITIONAL STEEL BASE 18" W/CONCRETE				2073
JIB-CB-36-BC	ADDITIONAL STEEL BASE 36" W/CONCRETE				5341

### Portable Offset Jib Cranes

Offset base design allows for larger usable work area beneath I-beam. Allows for easy transportation of jib crane with fork truck. Fixed length I-beam will pivot 360° for complete access. Empty base models include instructions for proper filling with concrete. Offset base size is 42-3/16" W x 42-3/16" L x 18"H or 36"H. Built-in fork tubes, measuring 7 1/2"W x 2 1/2"H usable on 24" centers, for transportation with fork truck. Steel construction with blue painted finish. Units ship knocked down. Not for use as a fork truck attachment. 10' under I-beam.



18"H base requires (41) 60 lb. bags of Sakrete mix

36"H base requires (82) 60 lb. bags of Sakrete mix

MODEL NUMBER	UNIFORM CAPACITY	I-BEAM LENGTH/HEIGHT	I-BEAM FLANGE WIDTH	BASE HEIGHT	WEIGHT (POUND)
<b>EMPTY BASE</b>					
JIB-CBX-25-8-10	250 lb.	96" / 6"	4"	18"	1240
JIB-CBX-25-10-10	250 lb.	120" / 6"	4"	18"	1193
JIB-CBX-50-8-10	500 lb.	96" / 6"	4"	18"	1169
JIB-CBX-50-10-10	500 lb.	120" / 10 1/8"	4"	36"	1446
JIB-CBX-100-8-10	1,000 lb.	96" / 10 1/8"	4"	36"	1332
<b>CONCRETE FILLED BASE</b>					
JIB-CBX-25-8-10-BC	250 lb.	96" / 6"	4"	18"	3527
JIB-CBX-25-10-10-BC	250 lb.	120" / 6"	4"	18"	3570
JIB-CBX-50-8-10-BC	500 lb.	96" / 6"	4"	18"	3527
JIB-CBX-50-10-10-BC	500 lb.	120" / 10 1/8"	4"	36"	6268
JIB-CBX-100-8-10-BC	1,000 lb.	96" / 10 1/8"	4"	36"	6234
<b>OPTIONAL OFFSET BASE - EMPTY</b>					
JIB-CBX-18-B	ADDITIONAL OFFSET STEEL BASE 18" HIGH - EMPTY				350
JIB-CBX-36-B	ADDITIONAL OFFSET STEEL BASE 36" HIGH - EMPTY				520
<b>OPTIONAL OFFSET BASE WITH CONCRETE</b>					
JIB-CBX-18-BC	ADDITIONAL OFFSET STEEL BASE 18"H W/CONCRETE				2870
JIB-CBX-36-BC	ADDITIONAL OFFSET STEEL BASE 36"H W/CONCRETE				5449

Festoon System

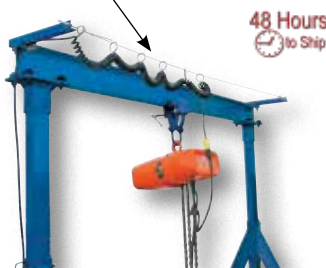

### Festoon System

Designed to keep power cords out of danger when using electric trolleys and/or hoists. Easily retrofits to any gantry or jib crane up to 240" (20 ft.) in length. Includes 22 feet of wire rope. 115V AC cord supplied. Works with both Steel and Aluminum Gantry Cranes.

MODEL NUMBER	DESCRIPTION	WEIGHT (POUND)
FES-KIT	KEEPS POWER CORDS OUT OF DANGER	16



## Multi-Station Transportable Jib Cranes

Designed for use in multiple locations, includes jib crane and one base socket. Extra base sockets may be purchased for use in other locations. Friction brake design allows positive locking and controlled rotation of heavy loads. 360° continuous rotation of heavy loads. Handles most applications up to 1,000 uniform pounds. Standard 6" high I-beam with 4" flange width. Rugged welded steel construction with painted blue finish. Hoist and trolley can be ordered separately, see pages 210-214. Requires reinforced concrete pad for installation.

MODEL NUMBER	OVERALL BOOM LENGTH	OVERALL HEIGHT	USABLE HEIGHT	BOOM REACH	UNIFORM CAPACITY	WEIGHT (POUND)
JIB-P-10-6-6	72"	84 <sup>11</sup> / <sub>16</sub> "	71 <sup>13</sup> / <sub>16</sub> "	67 <sup>3</sup> / <sub>4</sub> "	1,000 lb.	603
JIB-P-10-6-8	72"	108 <sup>11</sup> / <sub>16</sub> "	95 <sup>13</sup> / <sub>16</sub> "	67 <sup>3</sup> / <sub>4</sub> "	1,000 lb.	701
JIB-P-10-6-10	72"	132 <sup>11</sup> / <sub>16</sub> "	119 <sup>13</sup> / <sub>16</sub> "	67 <sup>3</sup> / <sub>4</sub> "	1,000 lb.	731
JIB-P-10-8-6	96"	84 <sup>11</sup> / <sub>16</sub> "	71 <sup>13</sup> / <sub>16</sub> "	91 <sup>3</sup> / <sub>4</sub> "	1,000 lb.	606
JIB-P-10-8-8	96"	108 <sup>11</sup> / <sub>16</sub> "	95 <sup>13</sup> / <sub>16</sub> "	91 <sup>3</sup> / <sub>4</sub> "	1,000 lb.	683
JIB-P-10-8-10	96"	132 <sup>11</sup> / <sub>16</sub> "	119 <sup>13</sup> / <sub>16</sub> "	91 <sup>3</sup> / <sub>4</sub> "	1,000 lb.	773
JIB-P-10-10-6	120"	84 <sup>11</sup> / <sub>16</sub> "	71 <sup>13</sup> / <sub>16</sub> "	115 <sup>3</sup> / <sub>4</sub> "	1,000 lb.	710
JIB-P-10-10-8	120"	108 <sup>11</sup> / <sub>16</sub> "	95 <sup>13</sup> / <sub>16</sub> "	115 <sup>3</sup> / <sub>4</sub> "	1,000 lb.	790
JIB-P-10-10-10	120"	132 <sup>11</sup> / <sub>16</sub> "	119 <sup>13</sup> / <sub>16</sub> "	115 <sup>3</sup> / <sub>4</sub> "	1,000 lb.	805
JIB-P-B	EXTRA BASE SOCKET, 34 <sup>1</sup> / <sub>2</sub> "H WITH 17" x 17" BASE					145



## Tie Rod Jibs (for high ceilings)

Achieve maximum floor space and utilize wasted air space. Mount to walls or columns to increase hook coverage over workstations. Unit rotates 180°. Usable I-beam length is 79<sup>3</sup>/<sub>4</sub>" while the overall length is 86". All steel construction with painted blue finish provides years of service. Hoist and trolley can be ordered separately, see pages 210-214.

MODEL NUMBER	CABLE SUPPORT LENGTH	OVERALL HEIGHT	I-BEAM FLANGE WIDTH x HEIGHT	UNIFORM CAPACITY	WEIGHT (POUND)
JIB-HC-3	82 <sup>1</sup> / <sub>4</sub> "	45 <sup>1</sup> / <sub>4</sub> "	2 <sup>11</sup> / <sub>16</sub> " x 4"	300 lb.	144
JIB-HC-6	82 <sup>1</sup> / <sub>4</sub> "	45 <sup>1</sup> / <sub>4</sub> "	2 <sup>11</sup> / <sub>16</sub> " x 4"	600 lb.	144
JIB-HC-10	76 <sup>3</sup> / <sub>4</sub> "	45 <sup>1</sup> / <sub>4</sub> "	2 <sup>11</sup> / <sub>16</sub> " x 4"	1,000 lb.	160
JIB-HC-20	76 <sup>3</sup> / <sub>4</sub> "	45 <sup>1</sup> / <sub>4</sub> "	4" x 6"	2,000 lb.	216

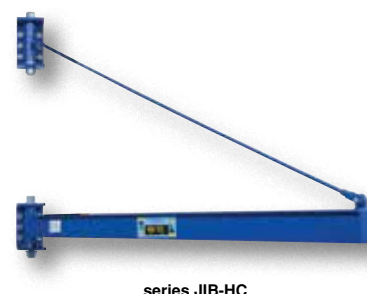

## Wall Jibs (for low ceilings)

Designed to assist workers in the maneuvering of materials, as well as achieving maximum headroom where low ceilings are of concern. This cantilever style jib crane mounts to true vertical wall members. Increases personnel productivity by lifting awkward materials. The overall I-beam length is 88" with a usable length of 80". Overall length of jib is 96<sup>1</sup>/<sub>8</sub>". Unit rotates 180°. Steel construction with painted blue finish. Hoist and trolley can be ordered separately, see pages 210-214.

MODEL NUMBER	UNDER I-BEAM TO BOTTOM FRAME	I-BEAM FLANGE WIDTH x HEIGHT	OVERALL HEIGHT	UNIFORM CAPACITY	WEIGHT (POUND)
JIB-LC-3	57"	2 <sup>11</sup> / <sub>16</sub> " x 4"	61"	300 lb.	304
JIB-LC-6	57"	4" x 6"	63"	600 lb.	328
JIB-LC-10	57"	4" x 6"	63"	1,000 lb.	332
JIB-LC-20	57"	4" x 10 <sup>1</sup> / <sub>8</sub> "	67 <sup>1</sup> / <sub>8</sub> "	2,000 lb.	405

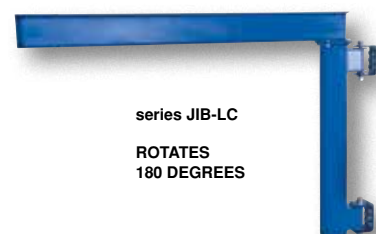

## Beam Clamps

Designed to reduce the I-beam flange stress by distributing loads away from the flange edges during overhead lifting applications. These versatile units can be interchanged from one gantry to another in a matter of seconds with the easy mechanical adjustment mechanism. A bar is located at the bottom of the beam clamp for attaching a hoist (sold separately). Steel construction and painted finish.

MODEL NUMBER	DESCRIPTION	BEAM FLANGE WIDTH	UNIFORM CAPACITY	WEIGHT (POUND)
BC-1	BEAM CLAMP	3 <sup>1</sup> / <sub>8</sub> " - 9 <sup>5</sup> / <sub>8</sub> "	1,000 lb.	10
BC-2	BEAM CLAMP	3 <sup>1</sup> / <sub>8</sub> " - 9 <sup>5</sup> / <sub>8</sub> "	2,000 lb.	11
BC-4	BEAM CLAMP	3 <sup>1</sup> / <sub>8</sub> " - 9 <sup>5</sup> / <sub>8</sub> "	4,000 lb.	12
BC-6	BEAM CLAMP	3 <sup>1</sup> / <sub>2</sub> " - 12 <sup>1</sup> / <sub>4</sub> "	6,000 lb.	28
BC-8	BEAM CLAMP	3 <sup>1</sup> / <sub>2</sub> " - 12 <sup>1</sup> / <sub>4</sub> "	8,000 lb.	38
BC-10	BEAM CLAMP	3 <sup>1</sup> / <sub>2</sub> " - 12 <sup>1</sup> / <sub>4</sub> "	10,000 lb.	45

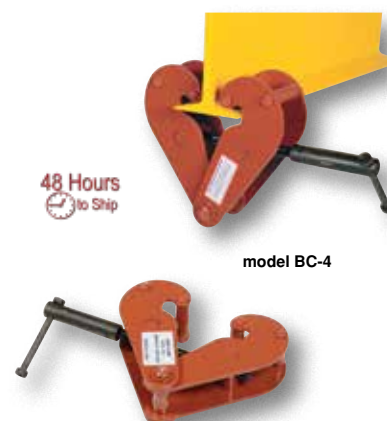



48 Hours  
to Ship

model QIT-2

model QIT-6



PUSH LOW PROFILE  
EYE MANUAL TROLLEY  
model E-MT-4



48 Hours  
to Ship

GEARED LOW PROFILE  
EYE MANUAL TROLLEY  
(FEATURES 10 FT. OF CHAIN)  
model E-MT-2-C



48 Hours  
to Ship

**New**

48 Hours  
to Ship

model VKX-05-5



## Quick Install Manual Trolleys

These trolleys are dependable, safe, and easy to use. Designed to easily adjust to the width of virtually any S, H, W, and M type I-beam. Width is adjusted with manual screw mechanism. Includes locking ring to prevent trolley width from changing accidentally. Manual screw mechanism may also be tightened to prevent trolley from moving (similar to a Beam Clamp). Each trolley includes four (4) rollers with sealed bearings for long life. A lifting eye is located at the bottom of the trolley for attaching a hoist (not included). Steel construction and painted finish.

MODEL NUMBER	FITS I-BEAM FLANGE WIDTH	HEADROOM	UNIFORM CAPACITY	WEIGHT (POUND)
QIT-03Ⓢ	3" to 5"	6¾"	300 lb.	13
QIT-06Ⓢ	3" to 5"	6¾"	600 lb.	13
QIT-1Ⓢ	3" to 5"	6¾"	1,000 lb.	13
QIT-2Ⓢ	3" to 5"	8½"	2,000 lb.	14
QIT-4Ⓢ	3" to 7½"	10"	4,000 lb.	17
QIT-6Ⓢ	3" to 7½"	10¾"	6,000 lb.	40
QIT-8Ⓢ	4" to 11¾"	13⅞"	8,000 lb.	68
QIT-10Ⓢ	4" to 11¾"	13⅞"	10,000 lb.	68
QIT-12Ⓢ	4" to 11¾"	13⅞"	12,000 lb.	70

## Low Profile Manual Trolleys

These trolleys have been designed to quickly install on virtually any S, H, W, and M type I-beam. The width of the trolley is adjusted by rotating the center rod with lifting eye clockwise or counterclockwise. Once hoist is attached, center rod cannot be rotated which prevents trolley width from accidentally changing. The trolley includes four (4) rollers with sealed bearings. Choose either push or geared trolley. Geared trolley is ideal for use when precise positioning is required. A lifting eye is located at the bottom of the trolley for attaching a hoist (sold separately). Steel construction and painted finish. Headroom is measured from bottom of wheel to bottom of hooking eye.

MODEL NUMBER	DESCRIPTION	I-BEAM FLANGE	HEADROOM	UNIFORM CAPACITY	WEIGHT (POUND)
E-MT-1Ⓢ	PUSH	2" to 8⅝"	2½"	1,000 lb.	12
E-MT-2Ⓢ	PUSH	2½" to 10⅝"	2⅝"	2,000 lb.	20
E-MT-4Ⓢ	PUSH	2½" to 8⅝"	3"	4,000 lb.	31
E-MT-6Ⓢ	PUSH	3" to 8⅝"	3⅝"	6,000 lb.	52
E-MT-8Ⓢ	PUSH	3" to 9"	4"	8,000 lb.	82
E-MT-10Ⓢ	PUSH	3" to 9"	4"	10,000 lb.	82
E-MT-1-CⓈ	GEARED	2½" to 5½"	4½"	1,000 lb.	21
E-MT-2-CⓈ	GEARED	2½" to 5½"	5"	2,000 lb.	29
E-MT-4-CⓈ	GEARED	3" to 6½"	6"	4,000 lb.	41
E-MT-6-CⓈ	GEARED	3" to 8"	7⅝"	6,000 lb.	62
E-MT-8-CⓈ	GEARED	3" to 9"	8⅝"	8,000 lb.	100
E-MT-10-CⓈ	GEARED	3" to 9"	8⅝"	10,000 lb.	103

## Low Headroom Combination Chain Hoist/Trolley

Use this to gain additional raised hook height. Chain hoist hook travel is 10 feet. Assembly required. Fits on wide flange or S-type I-beam.

MODEL NUMBER	DESCRIPTION	BOTTOM OF ROLLER TO TOP OF HOOK	I-BEAM FLANGE	UNIFORM CAPACITY	WEIGHT (POUND)
LOW-1PⓈ	PUSH	11¾"	2" - 6"	1,000 lb.	45
LOW-2PⓈ	PUSH	13"	2½" - 8"	2,000 lb.	63
LOW-4PⓈ	PUSH	16¼"	3½" - 8"	4,000 lb.	92
LOW-6PⓈ	PUSH	18¼"	4" - 8"	6,000 lb.	144
LOW-1GⓈ	GEARED	11¾"	2" - 6"	1,000 lb.	49
LOW-2GⓈ	GEARED	13"	2½" - 8"	2,000 lb.	73
LOW-4GⓈ	GEARED	16¼"	3½" - 8"	4,000 lb.	110
LOW-6GⓈ	GEARED	18¼"	4" - 8"	6,000 lb.	158

## Compact & Lightweight Lever Hoist (disc brake)

Compact and Lightweight Lever Hoists are ideal for use in confined areas when fastening, fixing or positioning of light load is required. High impact aluminum alloy housing with all the main parts made of heat treated alloy steel (more durable and longer life). Advanced gear reduction system (5 gears in the gear box) enables effortless handling and requires low hand-pull force for highly reliable lifting. Withstand 1500 cycles with 110% of rated capacity. Features lightweight high strength grade 100 chain. Heavy duty storage bag included.

MODEL NUMBER	UNIFORM CAPACITY	STANDARD LIFT (FEET)	MINIMUM DISTANCE BETWEEN HOOKS	HANDLE LENGTH	WEIGHT (POUND)
VKX-05-5Ⓢ	500 lb.	5	7⅞"	5¾"	6
VKX-10-5Ⓢ	1,000 lb.	5	9⅞"	6¼"	8

### Professional Lever Hoists (disc brake)

Hoists can be used at any angle and feature a 50% wider ratchet gear, high impact restraint gear case, and brake cover. Upper and lower swivel hooks with deformation indicators. Load chain guide system (allows operation in horizontal position). Minimum breaking load is 4 times that of rated capacity. Manufactured to ISO9002 quality standard. Every unit is tested to 150% of rated capacity and is issued with an individual test certificate.

MODEL NUMBER	UNIFORM CAPACITY	STANDARD LIFT (FEET)	MINIMUM DISTANCE BETWEEN HOOKS	HANDLE LENGTH	WEIGHT (POUND)
PLH-15-5Ⓢ	1,500 lb.	5	11"	11"	19
PLH-15-10Ⓢ	1,500 lb.	10	11"	11"	19
PLH-15-20Ⓢ	1,500 lb.	20	11"	11"	26
PLH-20-5Ⓢ	2,000 lb.	5	11 <sup>7</sup> / <sub>16</sub> "	10"	21
PLH-20-10Ⓢ	2,000 lb.	10	11 <sup>7</sup> / <sub>16</sub> "	10"	26
PLH-20-20Ⓢ	2,000 lb.	20	11 <sup>7</sup> / <sub>16</sub> "	10"	38
PLH-30-5Ⓢ	3,000 lb.	5	15 <sup>1</sup> / <sub>2</sub> "	16"	27
PLH-30-10Ⓢ	3,000 lb.	10	15 <sup>1</sup> / <sub>2</sub> "	16"	26
PLH-30-20Ⓢ	3,000 lb.	20	15 <sup>1</sup> / <sub>2</sub> "	16"	43
PLH-60-5Ⓢ	6,000 lb.	5	22 <sup>7</sup> / <sub>16</sub> "	16"	40
PLH-60-10Ⓢ	6,000 lb.	10	22 <sup>7</sup> / <sub>16</sub> "	16"	47
PLH-60-20Ⓢ	6,000 lb.	20	22 <sup>7</sup> / <sub>16</sub> "	16"	61
PLH-120-5Ⓢ	12,000 lb.	5	22 <sup>7</sup> / <sub>16</sub> "	14"	68
PLH-120-10Ⓢ	12,000 lb.	10	22 <sup>7</sup> / <sub>16</sub> "	14"	94
PLH-120-20Ⓢ	12,000 lb.	20	22 <sup>7</sup> / <sub>16</sub> "	14"	98

ADDITIONAL 12 POCKET TOOL STORAGE BAG, model BAG-12



model PLH-30-5

48 Hours to Ship



5 YEAR WARRANTY

### Mighty Mini Lever Hoists (disc brake)

Lightweight Mini Lever Hoists are durable and easy to operate. Single-hand "free chaining" is simple, allowing for trouble-free operation in the vertical or horizontal position. All the main parts are made of alloy steel and heat treated (more durable and longer life). Long life brake discs. Short lever handle can rotate in a complete 360° circle. Each hoist is tested to 150% of rated capacity. Features lightweight high strength grade 80 black finish load chain.

MODEL NUMBER	UNIFORM CAPACITY	STANDARD LIFT (FEET)	MINIMUM DISTANCE BETWEEN HOOKS	HANDLE LENGTH	WEIGHT (POUND)
ELH-05-5Ⓢ	500 lb.	5	8 <sup>1</sup> / <sub>4</sub> "	6"	4
ELH-05-10Ⓢ	500 lb.	10	8 <sup>1</sup> / <sub>4</sub> "	6"	9
ELH-05-15Ⓢ	500 lb.	15	8 <sup>1</sup> / <sub>4</sub> "	6"	13
ELH-05-20Ⓢ	500 lb.	20	8 <sup>1</sup> / <sub>4</sub> "	6"	17
ELH-10-5Ⓢ	1,000 lb.	5	10"	8 <sup>1</sup> / <sub>2</sub> "	6
ELH-10-10Ⓢ	1,000 lb.	10	10"	8 <sup>1</sup> / <sub>2</sub> "	11
ELH-10-15Ⓢ	1,000 lb.	15	10"	8 <sup>1</sup> / <sub>2</sub> "	15
ELH-10-20Ⓢ	1,000 lb.	20	10"	8 <sup>1</sup> / <sub>2</sub> "	20

ADDITIONAL 12 POCKET TOOL STORAGE BAG, model BAG-12



MIGHTY-MINI LEVER HOIST model ELH-05-10



1 YEAR WARRANTY

48 Hours to Ship



Rugged storage bag included with lever hoists under 6,000 lbs. Additional bags are available, model BAG-12

### Economy Lever Hoists (disc brake)

Single hand "free chaining" is simple, allowing trouble-free operation in the vertical or horizontal position. Lever handle can rotate in a complete 360° circle. Swivel hooks include deformation indicators. Each hoist is tested to 150% of rated capacity and issued with an individual test certificate.

MODEL NUMBER	UNIFORM CAPACITY	STANDARD LIFT (FEET)	MINIMUM DISTANCE BETWEEN HOOKS	HANDLE LENGTH	WEIGHT (POUND)
ELH-15-5Ⓢ	1,500 lb.	5	12 <sup>7</sup> / <sub>8</sub> "	11"	15
ELH-15-10Ⓢ	1,500 lb.	10	12 <sup>7</sup> / <sub>8</sub> "	11"	22
ELH-15-20Ⓢ	1,500 lb.	20	12 <sup>7</sup> / <sub>8</sub> "	11"	23
ELH-20-5Ⓢ	2,000 lb.	5	12 <sup>3</sup> / <sub>4</sub> "	10"	20
ELH-20-10Ⓢ	2,000 lb.	10	12 <sup>3</sup> / <sub>4</sub> "	10"	26
ELH-20-20Ⓢ	2,000 lb.	20	12 <sup>3</sup> / <sub>4</sub> "	10"	32
ELH-30-5Ⓢ	3,000 lb.	5	15"	16"	28
ELH-30-10Ⓢ	3,000 lb.	10	15"	16"	34
ELH-30-20Ⓢ	3,000 lb.	20	15"	16"	45
ELH-60-5Ⓢ	6,000 lb.	5	19"	16"	46
ELH-60-10Ⓢ	6,000 lb.	10	19"	16"	50
ELH-60-20Ⓢ	6,000 lb.	20	19"	16"	65
ELH-120-5Ⓢ	12,000 lb.	5	24 <sup>7</sup> / <sub>16</sub> "	14"	70
ELH-120-10Ⓢ	12,000 lb.	10	24 <sup>7</sup> / <sub>16</sub> "	14"	101
ELH-120-20Ⓢ	12,000 lb.	20	24 <sup>7</sup> / <sub>16</sub> "	14"	107

ADDITIONAL 12 POCKET TOOL STORAGE BAG, model BAG-12



48 Hours to Ship



1 YEAR WARRANTY



ECONOMY LEVER HOISTS model ELH-30-5



model  
PHCH-1-10

48 Hours  
to Ship

CA Residents see  
WARNING A, Pg. 459



model  
PHCH-3-10

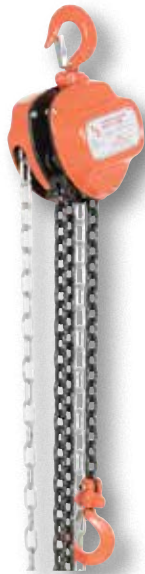

48 Hours  
to Ship

HAND CHAIN HOISTS  
series HCH

CA Residents see  
WARNING A, Pg. 459

48 Hours  
to Ship

model  
HCH-NS-1-10

CA Residents see  
WARNING A, Pg. 459



## Professional Hand Chain Hoists

These lightweight hoists are durable and easy to operate. Compact design and low headroom allow installation in confined areas. Heat-treated spur gear efficiently designed to provide smooth load handling and low hand chain pull. Reinforced double pawl brake system and larger diameter pawl springs ensure reliable braking. Designed with a safety factor 4 times the rated capacity. Individually tested at 150% of the rated capacity. Features lightweight, high strength grade 100 alloy steel load chain 25% stronger than grade 80 chain, pull chain, and forged steel upper and lower hooks with safety latches. Meets ANSI B30.16-2003 requirements.

MODEL NUMBER	UNIFORM CAPACITY	LIFT (FEET)	HEADROOM (INCHES)	WEIGHT (POUND)
PHCH-1-10 <sup>Ⓢ</sup>	1,000 lb.	10	11¼"	27
PHCH-1-15 <sup>Ⓢ</sup>	1,000 lb.	15	11¼"	35
PHCH-1-20 <sup>Ⓢ</sup>	1,000 lb.	20	11¼"	39
PHCH-2-10 <sup>Ⓢ</sup>	2,000 lb.	10	12 <sup>7</sup> / <sub>16</sub> "	34
PHCH-2-15 <sup>Ⓢ</sup>	2,000 lb.	15	12 <sup>7</sup> / <sub>16</sub> "	39
PHCH-2-20 <sup>Ⓢ</sup>	2,000 lb.	20	12 <sup>7</sup> / <sub>16</sub> "	46
PHCH-3-10 <sup>Ⓢ</sup>	3,000 lb.	10	13 <sup>3</sup> / <sub>8</sub> "	39
PHCH-3-15 <sup>Ⓢ</sup>	3,000 lb.	15	13 <sup>3</sup> / <sub>8</sub> "	45
PHCH-3-20 <sup>Ⓢ</sup>	3,000 lb.	20	13 <sup>3</sup> / <sub>8</sub> "	51
PHCH-4-10 <sup>Ⓢ</sup>	4,000 lb.	10	15 "	41
PHCH-4-15 <sup>Ⓢ</sup>	4,000 lb.	15	15 "	48
PHCH-4-20 <sup>Ⓢ</sup>	4,000 lb.	20	15 "	53
PHCH-6-10 <sup>Ⓢ</sup>	6,000 lb.	10	18 <sup>3</sup> / <sub>4</sub> "	56
PHCH-6-15 <sup>Ⓢ</sup>	6,000 lb.	15	18 <sup>3</sup> / <sub>4</sub> "	62
PHCH-6-20 <sup>Ⓢ</sup>	6,000 lb.	20	18 <sup>3</sup> / <sub>4</sub> "	70
PHCH-10-10 <sup>Ⓢ</sup>	10,000 lb.	10	23 <sup>5</sup> / <sub>8</sub> "	111
PHCH-10-15 <sup>Ⓢ</sup>	10,000 lb.	15	23 <sup>5</sup> / <sub>8</sub> "	114
PHCH-10-20 <sup>Ⓢ</sup>	10,000 lb.	20	23 <sup>5</sup> / <sub>8</sub> "	125

## Hand Chain Hoists

These lightweight hoists feature enclosed double ratchet pawls with self adjusting disc brake and a safety factor 4 times the rated capacity. Tested at 150% of the rated capacity. Features grade 80 black chain tempered to ISO 3077, pull chain, hardened two-stage gears, and forged steel upper and lower hooks with safety latches. Meets ANSI B30.16-2003 requirements.

MODEL NUMBER	UNIFORM CAPACITY	LIFT (FEET)	HEADROOM (INCHES)	WEIGHT (POUND)
HCH-1-10 <sup>Ⓢ</sup>	1,000 lb.	10	11"	24
HCH-1-15 <sup>Ⓢ</sup>	1,000 lb.	15	11"	28
HCH-1-20 <sup>Ⓢ</sup>	1,000 lb.	20	11"	32
HCH-2-10 <sup>Ⓢ</sup>	2,000 lb.	10	12"	26
HCH-2-15 <sup>Ⓢ</sup>	2,000 lb.	15	12"	32
HCH-2-20 <sup>Ⓢ</sup>	2,000 lb.	20	12"	37
HCH-3-10 <sup>Ⓢ</sup>	3,000 lb.	10	15"	43
HCH-3-15 <sup>Ⓢ</sup>	3,000 lb.	15	15"	49
HCH-3-20 <sup>Ⓢ</sup>	3,000 lb.	20	15"	99
HCH-4-10 <sup>Ⓢ</sup>	4,000 lb.	10	17½"	48
HCH-4-15 <sup>Ⓢ</sup>	4,000 lb.	15	17½"	54
HCH-4-20 <sup>Ⓢ</sup>	4,000 lb.	20	17½"	117
HCH-6-10 <sup>Ⓢ</sup>	6,000 lb.	10	19"	59
HCH-6-15 <sup>Ⓢ</sup>	6,000 lb.	15	19"	64
HCH-6-20 <sup>Ⓢ</sup>	6,000 lb.	20	19"	132
HCH-10-10 <sup>Ⓢ</sup>	10,000 lb.	10	21"	111
HCH-10-15 <sup>Ⓢ</sup>	10,000 lb.	15	21"	117
HCH-10-20 <sup>Ⓢ</sup>	10,000 lb.	20	21"	176

## Non-Sparking Chain Hoists

Non-sparking brass construction. Brake engages automatically as soon as the hand chain stops moving. Forged load hooks. Low gear ratio reduces effort required for lifting. Satisfies relevant ANSI B30.16-2003 requirements.

MODEL NUMBER	UNIFORM CAPACITY	LIFT (FEET)	HEAD ROOM	WEIGHT (POUND)
HCH-NS-1-10 <sup>Ⓢ</sup>	1,000 lbs.	10	14"	35
HCH-NS-2-10 <sup>Ⓢ</sup>	2,000 lbs.	10	14"	47

## Economy Chain Hoists with Chain Container

These compact hoists feature a high efficiency motor with 24V push-button operation. Hand control features a convenient 15' cord. Single (1) or three (3) AC phase power available. Innovative design makes unit more resistant to dust and water, load limit fitted, and features a 4:1 safety factor. Chain container included.

MODEL NUMBER	UNIFORM CAPACITY	FEET PER MINUTE	HEAD ROOM	LIFT (FEET)	POWER	VOLTAGE	WEIGHT (POUND)
H-1000-1 <sup>Ⓢ</sup>	1,000 lb.	17"	21 <sup>7</sup> / <sub>16</sub> "	15	1 PHASE	110/220V	182
H-2000-1 <sup>Ⓢ</sup>	2,000 lb.	17"	22 <sup>13</sup> / <sub>16</sub> "	15	1 PHASE	110/220V	194
H-4000-1 <sup>Ⓢ</sup>	4,000 lb.	8 <sup>1</sup> / <sub>2</sub> "	21 <sup>7</sup> / <sub>16</sub> "	15	1 PHASE	110/220V	205
H-6000-1 <sup>Ⓢ</sup>	6,000 lb.	5 <sup>1</sup> / <sub>2</sub> "	29 <sup>1</sup> / <sub>8</sub> "	15	1 PHASE	110/220V	215
H-10000-1 <sup>Ⓢ</sup>	10,000 lb.	3 <sup>1</sup> / <sub>2</sub> "	31 <sup>1</sup> / <sub>8</sub> "	15	1 PHASE	110/220V	342
H-1000-3 <sup>Ⓢ</sup>	1,000 lb.	20 <sup>1</sup> / <sub>2</sub> "	21 <sup>7</sup> / <sub>16</sub> "	15	3 PHASE	220/440V	185
H-2000-3 <sup>Ⓢ</sup>	2,000 lb.	17"	22 <sup>13</sup> / <sub>16</sub> "	15	3 PHASE	220/440V	189
H-4000-3 <sup>Ⓢ</sup>	4,000 lb.	16"	21 <sup>7</sup> / <sub>16</sub> "	15	3 PHASE	220/440V	198
H-6000-3 <sup>Ⓢ</sup>	6,000 lb.	6 <sup>7</sup> / <sub>8</sub> "	29 <sup>1</sup> / <sub>8</sub> "	15	3 PHASE	220/440V	215
H-10000-3 <sup>Ⓢ</sup>	10,000 lb.	4 <sup>1</sup> / <sub>4</sub> "	31 <sup>1</sup> / <sub>8</sub> "	15	3 PHASE	220/440V	342

## Electric Chain Hoists 115V 1-PHASE & 460V 3-PHASE STANDARD

Ruggedly built with power to handle most industrial lifting applications. Includes push-button hand pendant with raise and lower functions on a 6' cord. Single (1) and three (3) phase AC power available. Optional Chain Container stores surplus chain overhead to keep from interfering with operation. Additional lifting heights and speeds available, contact factory.

MODEL NUMBER	UNIFORM CAPACITY	FEET PER MINUTE	HEAD ROOM	LIFT (FEET)	POWER	WEIGHT (POUND)
ECH-03	300 lb.	16	11 <sup>1</sup> / <sub>16</sub> "	10	1 PHASE	26
ECH-06	600 lb.	8	11 <sup>1</sup> / <sub>16</sub> "	10	1 PHASE	28
ECH-10-1PH	1,000 lb.	15	14"	10	1 PHASE	105
ECH-20-1PH	2,000 lb.	14	16"	10	1 PHASE	122
ECH-40-1PH	4,000 lb.	7	22 <sup>1</sup> / <sub>2</sub> "	10	1 PHASE	152
ECH-60-1PH	6,000 lb.	3.5	29 <sup>1</sup> / <sub>2</sub> "	10	1 PHASE	207
ECH-10-3PH	1,000 lb.	15	14"	10	3 PHASE	106
ECH-20-3PH	2,000 lb.	14	16"	10	3 PHASE	122
ECH-40-3PH	4,000 lb.	14	22"	10	3 PHASE	152
ECH-60-3PH	6,000 lb.	17	26"	10	3 PHASE	269
ECH-80-3PH	8,000 lb.	11	32"	10	3 PHASE	306
ECH-100-3PH	10,000 lb.	11	32"	10	3 PHASE	315
ECH-CC	CHAIN CONTAINER (FITS 300 & 600 LB. UNITS)					2
ECH-CC-K	CHAIN CONTAINER (FITS 1,000 TO 4,000 LB. UNITS)					5
ECH-CC-6-K	CHAIN CONTAINER (FITS 6,000 LB. UNITS)					6
ECH-CC-810-K	CHAIN CONTAINER (FITS 8,000 TO 10,000 LB. UNITS)					7

## Variable Speed Electric Chain Hoists 1-PHASE STANDARD

Variable Speed Electric Chain Hoists add exceptional value since these hoists save on maintenance, repair, and downtime costs over its lifetime. Standard push button hand control with up/down controls and variable speed knob. Chain container included.

MODEL NUMBER	UNIFORM CAPACITY	VARIABLE SPEED (F.P.M.)	HEAD ROOM	LIFT (FEET)	VOLTAGE	WEIGHT (POUND)
VS-ECH-2-1PH <sup>Ⓢ</sup>	250 lb.	0-49	18"	13	115	41
VS-ECH-5-1PH <sup>Ⓢ</sup>	500 lb.	0-49	18"	13	220	44
VS-ECH-10-1PH <sup>Ⓢ</sup>	1,000 lb.	0-20	18"	13	220	50

## Manipulator Style Control Electric Chain Hoist 115V 1-PHASE STANDARD

Features in-line hand grip, which allows one handed operation and gives the operator a free hand to easily position the load. Rocker switch above hand grip for quick selection between low and high speed control. Adjustable speeds and single phase power. Lightweight and compact die cast aluminum body. Chain container included.

MODEL NUMBER	UNIFORM CAPACITY	HIGH SPEED F.P.M.	LOW SPEED F.P.M.	HEAD ROOM	LIFT (FEET)	WEIGHT (POUND)
ECH-50M-6-1PH	525 lb.	44	10	37 <sup>7</sup> / <sub>8</sub> "	6	44

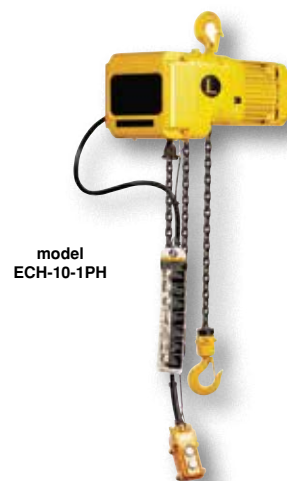



model  
ECH-ED-10-1PH

series ACH  
shown with optional  
chain container

## High Speed Electric Chain Hoist 115V 1-PHASE STANDARD

This high speed single phase electric chain hoist offers the ability to lift heavy loads with ease and precision. Light, compact, and powerful; this hoist can be easily installed, transported and offers high lifting speed. Features include double braking system for added protection, heavy-duty motor for industrial applications, high performance friction clutch to prevent overwinding and corrosion-resistant nickel-plated load chain. Chain container included.

MODEL NUMBER	UNIFORM CAPACITY	FEET PER MINUTE	HEAD ROOM	LIFT (FEET)	POWER	WEIGHT (POUND)
ECH-ED-10-1PH	1,050 lb.	22	20½"	10	1 PHASE	46

## Air Powered Chain Hoists

Heavy-duty air chain hoist can be used as a workstation hoist or as a production line hoist. Lightweight, rugged, and compact design - for ease of portability - makes this hoist perfect for most air hoist lifting applications. Standard lift is 10' assuming 90 PSI air pressure. Variable flow, two (2) lever pendant for precise load spotting.

MODEL NUMBER	UNIFORM CAPACITY	LIFTING F.P.M.	LIFT (FEET)	WEIGHT (POUND)
ACH-25	250 lb.	42	10	19
ACH-50	500 lb.	29	10	28
ACH-60	600 lb.	16	10	34
ACH-100	1,000 lb.	11	10	34
ACH-CC-C	CHAIN CONTAINER 4½"W x 3"L x 5½"H			2



model CSW-30



## Drill Powered Hoist

Drill Powered Hoist for powered lifting in remote locations. Hoist can be used in single or double line pull. 230 in-lb. input torque required for maximum lifting capacity.

MODEL NUMBER	CABLE SIZE	UNIFORM CAPACITY	GEAR RATIO	CABLE LENGTH	WEIGHT (POUND)
CSW-30	3/16"	1,200 lb.	103:1	40 foot	12



model EMH-3



## Electric Mini Hanging Cable Hoists - Suspension Type

Lightweight and compact design ideal for a wide range of applications for construction sites, rigging, warehouse, storage area, confined spaces and plumbing. Easily mounts to most scaffolding and beams (secured with latch hook). Robust design, strong steel construction and durable powder coated finish. Dual braking systems provides instant and safe braking. Built in raise/lower limit switch prevents excessive winding. 360° swivel hook with safety latch. Thermal overload on the motor for added safety. Quick disconnect power and hand control cord. Low noise and smooth operation. Cable length is 90 feet. 115V 1-PHASE STANDARD

MODEL NUMBER	LIFTING CAPACITY	CABLE SIZE	LIFTING SPEED (FEET PER MINUTE)	WEIGHT (POUND)
EMH-3	300 lb.	3/16"	60'	51
EMH-5	500 lb.	3/16"	39'	62
EMH-7	700 lb.	3/16"	39'	66
EMH-10	1,000 lb.	1/4"	39'	74



model MINI-2

## Mini Cable Hoists 115V 1-PHASE STANDARD

Use in single-line and double-line lifting applications. Cable length is 36' when used as a single-line - 18' when used as a double-line. Includes electric motor and hand-held push button controls. Installation bracket will fit on 1½" round pipe or 1½" square tubing. Optional Swivel Hook Plate must be ordered for attaching hoist to a trolley (trolley not included). Hand pendant control cord is 5' long.

MODEL NUMBER	SINGLE-LINE CAPACITY	DOUBLE-LINE CAPACITY	LIFTING SPEED (FEET PER MINUTE)	WEIGHT (POUND)
MINI-2	200 lb.	400 lb.	30'	26
MINI-4	400 lb.	800 lb.	30'	38
MINI-7	750 lb.	1,500 lb.	30'	47
MINI-10	1,000 lb.	2,000 lb.	30'	83

SWIVEL HOOK PLATE FOR MINI-2 OR MINI-4 ONLY, MODEL MINI-SH

## Gantry Sling Racks

Gantry Sling Racks are a great addition to any manufacturing and industrial facility. The strong steel construction, with a baked in powder coat finish, adds toughness and allows for hanging of items both large and small. The lower rack is adjustable to different heights to better suit the user's needs. The included hooks enable the user to hang items from both sides and in offset positions due to their adjustability. This sling rack can be utilized as a stationary or portable unit. Casters and mounting pads are included for the user to choose the desired function type.

MODEL NUMBER	STYLE	OVERALL WIDTH	OVERALL DEPTH	OVERALL HEIGHT	UNIFORM CAPACITY	WEIGHT (POUND)
SLR-UM-6 <sup>Ⓢ</sup>	STATIONARY	77"	36"	75 <sup>1</sup> / <sub>4</sub> "	2,000 lb.	140
	PORTABLE	77"	39"	78 <sup>1</sup> / <sub>2</sub> "	1,200 lb.	164
<b>OPTIONS</b>						
SLR-LS <sup>Ⓢ</sup>	SLING RACK HOOK LOCK SYSTEM (For one level, includes (2) two locking bars and (2) two locking brackets)					24
SLR-HK <sup>Ⓢ</sup>	SLING RACK HOOK maximum capacity per double hook is 150 lb.					15



model SLR-UM-6

## Polyester Lifting Slings - Double Ply

For medium to heavy-duty lifting, these double-ply lifting slings are the practical, economical answer to many lifting problems. TYPE III style with fabric ends has flat tapered eyes at both ends and can be used for all hitch types. Double capacity when used in basket-style. Reduce capacity 20% when used in choker-style. These slings meet DIN-EN 1492-1, ANSI standard B30.9 and OSHA requirements.

MODEL NUMBER	STRAIGHT LIFT UNIFORM CAPACITY	LENGTH (FEET)	WIDTH (INCHES)	COLOR CODE	WEIGHT (POUND)
SL-2-F-4 <sup>Ⓢ</sup>	3,200 lb.	4	1	GRAY	2
SL-2-F-6 <sup>Ⓢ</sup>	2,000 lb.	6	1	PURPLE	2
SL-2-F-8 <sup>Ⓢ</sup>	2,000 lb.	8	1	PURPLE	2
SL-2-F-10 <sup>Ⓢ</sup>	2,000 lb.	10	1	PURPLE	2
SL-4-F-4 <sup>Ⓢ</sup>	4,000 lb.	4	2	GREEN	2
SL-4-F-6 <sup>Ⓢ</sup>	4,000 lb.	6	2	GREEN	2
SL-4-F-8 <sup>Ⓢ</sup>	4,000 lb.	8	2	GREEN	2
SL-4-F-10 <sup>Ⓢ</sup>	4,000 lb.	10	2	GREEN	2
SL-6-F-4 <sup>Ⓢ</sup>	8,800 lb.	4	3	GRAY	4
SL-6-F-6 <sup>Ⓢ</sup>	6,000 lb.	6	3	YELLOW	4
SL-6-F-8 <sup>Ⓢ</sup>	8,800 lb.	8	3	GRAY	3
SL-6-F-10 <sup>Ⓢ</sup>	6,000 lb.	10	3	YELLOW	3
<b>PACKS OF TEN (10)</b>					
SL-2-F-6-10PK	2,000 lb.	6	1	PURPLE	
SL-2-F-8-10PK	2,000 lb.	8	1	PURPLE	
SL-2-F-10-10PK	2,000 lb.	10	1	PURPLE	
SL-4-F-4-10PK	4,000 lb.	4	2	GREEN	
SL-4-F-6-10PK	4,000 lb.	6	2	GREEN	
SL-4-F-8-10PK	4,000 lb.	8	2	GREEN	
SL-4-F-10-10PK	4,000 lb.	10	2	GREEN	



model SL-2-F-8



model SL-2-F-4



model SL-4-F-4



model SL-6-F-10

## Non-Marring Plate Clamps

Designed for lifting and revolving material without marring; smooth or polished plates such as stainless steel, aluminum, pre-lacquered plates, wood, marble, concrete, glass, plastic, or other fragile surfaces. Designed to meet ANSI B30.20-24 standards. Clamps have a permanently attached chain sling with a large oval suspension ring and non-marring polyurethane coated jaws. Lift only one plate at a time.

MODEL NUMBER	MINIMUM PLATE THICKNESS	MAXIMUM PLATE THICKNESS	UNIFORM CAPACITY	OVERALL DIMENSIONS (W x L x H)	WEIGHT (POUND)
NMPC-11	0	0.81	1,100 lb.	5" x 6" x 8"	11
NMPC-33	0	1.13	3,300 lb.	5" x 7" x 10"	26
NMPC-11-3	0	3.94	1,100 lb.	5" x 7" x 10"	15
NMPC-11-4	0.81	4.25	1,100 lb.	5" x 6" x 10"	15
NMPC-11-5	1.56	5.5	1,100 lb.	5" x 8" x 8"	15



NMPC-11-4



NMPC-11



### Positive Locking Plate Clamps

Grips sheet until release ring is pulled. Serrated gripper is hardened tool steel. Forged head and gear. Safety factor is 2 to 1. Baked-in powder-coated toughness. Designed to meet ASME B30.20 standards. Do not use plate clamps to lift loads less than 20% of rated capacity. Lift only one plate at a time. Plate must be clean and free of oil. *Not designed to use on stainless steel or aluminum plates. For use with materials with a surface hardness to 30 RC (300 HB).*

MODEL NUMBER	MINIMUM PLATE THICKNESS	MAXIMUM PLATE THICKNESS	MIN UNIFORM PLATE WEIGHT (POUND)	UNIFORM WORKING LOAD LIMIT	THROAT DEPTH	BALE OPENING	WEIGHT (POUND)
LPC-20 <sup>Ⓢ</sup>	0	0.80"	400 lb.	2,000 lb.	2.30"	1.75"	9
LPC-40 <sup>Ⓢ</sup>	0	1.1875"	800 lb.	4,000 lb.	2.95"	2.2"	13
LPC-60 <sup>Ⓢ</sup>	0	1.5625"	1,200 lb.	6,000 lb.	3.34"	1.9"	21



### Vertical Plate Clamps with Chain

Designed for lifting plate material in a vertical position. Lifting eye includes chain for greater versatility. Heavy-duty steel construction for years of reliable use. Meets ASME B30.20 specifications. Do not use plate clamps to lift loads less than 20% of rated capacity. Lift only one plate at a time. Plate must be clean and free of oil. *Not designed to use on stainless steel or aluminum plates. For use with materials with a surface hardness to 30 RC (300 HB).*

MODEL NUMBER	MINIMUM PLATE THICKNESS	MAXIMUM PLATE THICKNESS	MIN UNIFORM PLATE WEIGHT (POUND)	UNIFORM WORKING LOAD LIMIT	THROAT DEPTH	BALE OPENING	WEIGHT (POUND)
CPC-10 <sup>Ⓢ</sup>	0	0.6"	200 lb.	1,000 lb.	1.25"	2.25"	6
CPC-20 <sup>Ⓢ</sup>	0	0.8"	400 lb.	2,000 lb.	3"	3.00"	14
CPC-40 <sup>Ⓢ</sup>	0	1"	800 lb.	4,000 lb.	3"	3.75"	17
CPC-80 <sup>Ⓢ</sup>	0	1.1875"	1,320 lb.	6,600 lb.	3"	5.25"	33



### Vertical Plate Clamps

Pivoting bail for easier and more versatile operation. Automatic serrated hardened steel cams and pads. Drop-forged steel case for maximum strength. Designed to meet ASME B30.20. Warning: Do not exceed the working load limit. Serious bodily injury or property damage may result. Do not use plate clamps to lift loads less than 20% of rated capacity. Lift only one plate at a time. Plate must be clean and free of oil. *Not designed to use on stainless steel or aluminum plates. For use with materials with a surface hardness to 30 RC (300 HB).*

MODEL NUMBER	MINIMUM PLATE THICKNESS	MAXIMUM PLATE THICKNESS	MIN UNIFORM PLATE WEIGHT (POUND)	UNIFORM WORKING LOAD LIMIT	THROAT DEPTH	BALE OPENING	WEIGHT (POUND)
EPC-10 <sup>Ⓢ</sup>	0	0.59"	200 lb.	1,000 lb.	1.6"	1.81"	5
EPC-20 <sup>Ⓢ</sup>	0	0.78"	400 lb.	2,000 lb.	2.9"	2.38"	16
EPC-40 <sup>Ⓢ</sup>	0	1.00"	800 lb.	4,000 lb.	2.9"	2.38"	17
EPC-80 <sup>Ⓢ</sup>	0	1.19"	1,320 lb.	6,600 lb.	3.0"	2.38"	32



### Horizontal Plate Clamps

Designed for lifting plate material in horizontal position. Heavy-duty steel construction for years of reliable use. Meets ASME B30.20 specifications. Do not use plate clamps to lift loads less than 20% of rated capacity. Lift only one plate at a time. Plate must be clean and free of oil. *Not designed to use on stainless steel or aluminum plates. For use with materials with a surface hardness to 30 RC (300 HB).*

MODEL NUMBER	MINIMUM PLATE THICKNESS	MAXIMUM PLATE THICKNESS	MIN UNIFORM PLATE WEIGHT (POUND)	UNIFORM WORKING LOAD LIMIT	BALE OPENING	WEIGHT (POUND)
HPC-20 <sup>Ⓢ</sup>	0	0.8125"	400 lb.	2,000 lb.	1.1875"	9
HPC-40 <sup>Ⓢ</sup>	0	1.25"	800 lb.	4,000 lb.	1.2"	12
HPC-80 <sup>Ⓢ</sup>	0	1.375"	1,600 lb.	8,000 lb.	1.2"	15
HPC-100 <sup>Ⓢ</sup>	0	1.4375"	2,800 lb.	10,000 lb.	1.2"	17



## Heavy-Duty Beam Tongs

Designed for lifting I-beams with an overhead lifting device. The heavier the load the stronger the grip. Includes lifting ring for easy use with overhead hoist. Loads need to be centered and guided during lifting and moving operation. Manufactured to ASME B30.20 standards.

MODEL NUMBER	UNIFORM WORKING LOAD LIMIT	MAXIMUM BEAM WIDTH	WEIGHT (POUND)
BT-20 <sup>Ⓢ</sup>	2,000 lb.	6"	12
BT-40 <sup>Ⓢ</sup>	4,000 lb.	8"	21
BT-60 <sup>Ⓢ</sup>	6,000 lb.	10"	27

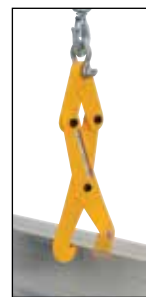

HEAVY-DUTY  
BEAM TONGS  
series BT

POWDER  
COATED  
TOUGH

## Heavy-Duty Die Lifting Tongs

Designed for lifting dies with overhead lifting devices. Includes lifting ring for easy use with overhead hoist. Manufactured to ASME B30.20 standards.

MODEL NUMBER	UNIFORM WORKING LOAD LIMIT	MAXIMUM WIDTH OPENING	WEIGHT (POUND)
DLT-20 <sup>Ⓢ</sup>	2,000 lb.	20 <sup>1</sup> / <sub>4</sub> "	67
DLT-25 <sup>Ⓢ</sup>	2,500 lb.	28 <sup>1</sup> / <sub>2</sub> "	76
DLT-30 <sup>Ⓢ</sup>	3,000 lb.	38 <sup>9</sup> / <sub>16</sub> "	93

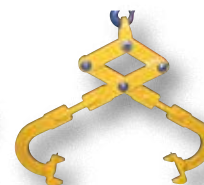

HEAVY-DUTY  
DIE LIFTING TONGS  
series DLT

## Heavy-Duty Pipe Grabs

Designed for lifting pipe with overhead lifting device. Automatic gripping and stabilizing arms allows for easy single person operation. Loads must be centered and guided during lifting operations. Heavy-duty steel construction with yellow baked-in powder-coated toughness.

MODEL NUMBER	PIPE STYLE	UNIFORM WORKING LOAD LIMIT	WORKS WITH PIPE O.D.	WEIGHT (POUND)
PG-C-045 <sup>Ⓢ</sup>	CAST IRON	450 lb.	3 <sup>1</sup> / <sub>2</sub> " TO 4"	21
PG-C-060 <sup>Ⓢ</sup>	CAST IRON	600 lb.	4 <sup>1</sup> / <sub>2</sub> " TO 4 <sup>3</sup> / <sub>4</sub> "	22
PG-C-100 <sup>Ⓢ</sup>	CAST IRON	1,000 lb.	5 <sup>1</sup> / <sub>2</sub> " TO 7"	26
PG-C-140 <sup>Ⓢ</sup>	CAST IRON	1,400 lb.	8 <sup>5</sup> / <sub>8</sub> " TO 9"	40
PG-C-200 <sup>Ⓢ</sup>	CAST IRON	2,000 lb.	10 <sup>3</sup> / <sub>4</sub> " TO 11"	113
PG-S-045 <sup>Ⓢ</sup>	STEEL	450 lb.	3 <sup>1</sup> / <sub>2</sub> " TO 4"	22
PG-S-060 <sup>Ⓢ</sup>	STEEL	600 lb.	4 <sup>1</sup> / <sub>2</sub> " TO 4 <sup>3</sup> / <sub>4</sub> "	21
PG-S-100 <sup>Ⓢ</sup>	STEEL	1,000 lb.	5 <sup>1</sup> / <sub>2</sub> " TO 7"	26
PG-S-140 <sup>Ⓢ</sup>	STEEL	1,400 lb.	8 <sup>5</sup> / <sub>8</sub> " TO 9"	40
PG-S-200 <sup>Ⓢ</sup>	STEEL	2,000 lb.	10 <sup>3</sup> / <sub>4</sub> " TO 11"	117



48 Hours  
to Ship

POWDER  
COATED  
TOUGH

series PG-S



HEAVY-DUTY PIPE GRABS  
series PG-C



COIL LIFTER  
model HDP-CL

### Coil Lifter

The hoist mounted Coil Lifter has adjustable balance points to accommodate different sized coils. Maximum coil diameter is 65¼", maximum coil length is 32⅝". The top adjusting bail allows the operator to insure level transportation of load. Compact for easy storage. Steel construction with blue painted finish.

MODEL NUMBER	ROD LENGTH	ROD DIAMETER	OVERALL WIDTH	UNIFORM CAPACITY	WEIGHT (POUND)
HDP-CL	36"	2¾"	21"	1,500 lb.	375



COIL HOOK  
model CH-10-6



### Overhead Coil Hooks

Designed for lifting heavy coils with an overhead lifting device. Easily position coils from horizontal to vertical position. Steel construction with yellow baked-in powder-coated toughness.

MODEL NUMBER	LIFTING CAPACITY	MAXIMUM COIL WIDTH	MAXIMUM COIL RADIAL	MINIMUM COIL INSIDE DIAMETER	WEIGHT (POUND)
CH-10-6	1,000 lb.	6"	13"	9"	22
CH-10-12	1,000 lb.	12"	13"	13"	28
CH-20-8	2,000 lb.	8"	16"	10"	25

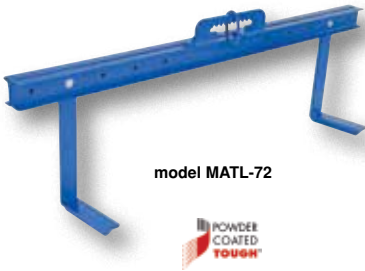

model MATL-72



### Bar Stock Material Positioners

Bar stock material positioners includes two adjustable-width lifting arms. Lifting arm width is adjustable in 6" increments along entire span. Lifting arm usable height is 18" while the length is 12". Arms are sloped back for material retention. Features adjustable overhead lifting bale for leveling load.

MODEL NUMBER	MAXIMUM ARM WIDTH	MINIMUM ARM WIDTH	OVERALL WIDTH	UNIFORM CAPACITY	WEIGHT (POUND)
MATL-72	72"	24"	78"	2,000 lb.	186
MATL-120	120"	24"	126"	2,000 lb.	280
MATL-144*	144"	24"	150"	2,000 lb.	320
MATL-ARM	EXTRA LIFTING ARM				35

\*LIQUID PAINT FINISH



### Heavy Duty Load Lifter

Designed for lifting uneven awkward sized loads. Adjust bail position left or right by turning hand crank. Includes chains for connecting to load (connector links and hooks are not included). For use with overhead lifting device (sold separately). Steel construction with painted finish.

MODEL NUMBER	OVERALL SIZE (W x H x D)	CHAIN LENGTH	UNIFORM CAPACITY	WEIGHT (POUND)
HDLL-15	25½" x 12½" x 7 <sup>9</sup> / <sub>16</sub> "	42"	1,500 lb.	18



### Spreader Beam Roll Lifter

Adjustable roll lifter utilizes your overhead hoist to position roll material. Ideal when headroom is limited. Designed to meet ASME B30.20. Width is adjustable on 4" increments. Includes two (2) four foot polyester lifting slings, looped ends.

MODEL NUMBER	DESCRIPTION	MAXIMUM ROLL LENGTH	CORE ROD SIZE	UNIFORM CAPACITY	WEIGHT (POUND)
SBRL-25	ROLL LIFTER	6 ft.	2½"	2,500 lb.	280
SBRL-40	ROLL LIFTER	6 ft.	2½"	4,000 lb.	350
SBRL-80*	ROLL LIFTER	8 ft.	2¾"	8,000 lb.	520

\*LIQUID PAINT FINISH



model SBRL-25

## Economy Spreader Beams

These versatile lifters are ideal for lifting a variety of loads where headroom is limited. Complies with OSHA and ANSI B30.20 standards. Two (2) safety swivel hooks included. Usable bail 3" wide by 5" high. Features heavy-duty welded steel construction and a baked-in powder-coated toughness.

MODEL NUMBER	MINIMUM/MAXIMUM SPREAD	HEADROOM	UNIFORM CAPACITY	WEIGHT (POUND)
<b>SBM-10-3</b> Ⓢ	21" / 33"	14"	1,000 lb.	67
<b>SBM-10-4</b>	33" / 45"	14"	1,000 lb.	75
<b>SBM-10-6</b> Ⓢ	45" / 69"	14"	1,000 lb.	96
<b>SBM-10-8</b>	69" / 93"	14"	1,000 lb.	105
<b>SBM-10-10</b>	93" / 117"	14"	1,000 lb.	141
<b>SBM-10-12</b> Ⓢ*	117" / 141"	14"	1,000 lb.	212
<b>SBM-20-3</b> Ⓢ	21" / 33"	14"	2,000 lb.	54
<b>SBM-20-4</b> Ⓢ	33" / 45"	14"	2,000 lb.	61
<b>SBM-20-6</b> Ⓢ	45" / 69"	14"	2,000 lb.	103
<b>SBM-20-8</b>	69" / 93"	14"	2,000 lb.	159
<b>SBM-20-10</b>	93" / 117"	15"	2,000 lb.	188
<b>SBM-20-12</b> *	117" / 141"	15"	2,000 lb.	232
<b>SBM-40-3</b> Ⓢ	21" / 33"	14 <sup>3</sup> / <sub>8</sub> "	4,000 lb.	76
<b>SBM-40-4</b>	33" / 45"	14 <sup>3</sup> / <sub>8</sub> "	4,000 lb.	112
<b>SBM-40-6</b> Ⓢ	45" / 69"	15 <sup>3</sup> / <sub>8</sub> "	4,000 lb.	147
<b>SBM-40-8</b>	69" / 93"	18 <sup>3</sup> / <sub>8</sub> "	4,000 lb.	222
<b>SBM-40-10</b>	93" / 117"	18 <sup>3</sup> / <sub>8</sub> "	4,000 lb.	275
<b>SBM-40-12</b> Ⓢ*	117" / 141"	18 <sup>3</sup> / <sub>8</sub> "	4,000 lb.	295
<b>SBM-60-3</b> Ⓢ	21" / 33"	15 <sup>11</sup> / <sub>16</sub> "	6,000 lb.	78
<b>SBM-60-4</b>	33" / 45"	15 <sup>11</sup> / <sub>16</sub> "	6,000 lb.	146
<b>SBM-60-6</b> Ⓢ	45" / 69"	18 <sup>11</sup> / <sub>16</sub> "	6,000 lb.	187
<b>SBM-60-8</b>	69" / 93"	18 <sup>11</sup> / <sub>16</sub> "	6,000 lb.	247
<b>SBM-60-10</b> Ⓢ	93" / 117"	18 <sup>11</sup> / <sub>16</sub> "	6,000 lb.	305
<b>SBM-60-12</b> *	117" / 141"	18 <sup>11</sup> / <sub>16</sub> "	6,000 lb.	393

\*LIQUID PAINT FINISH

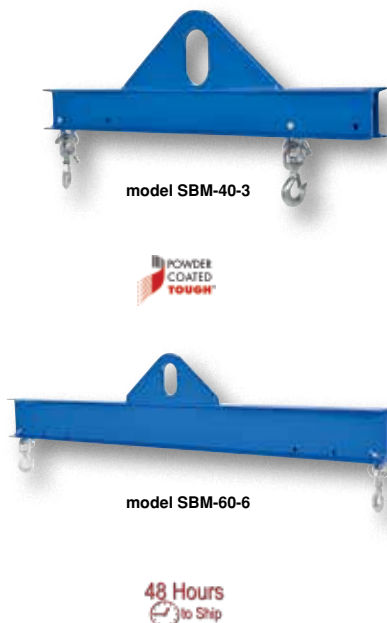

## Adjustable Spreader Beams

Lift uneven loads and keep them level with increased safety. Includes two lower bails and one upper bail. Adjust bails in 4" increments. The bails slide between two 5" high C-Channels (8" high model SBM-80). Meets ASME B30.20-1993 standard. Baked-in powder-coated toughness.

MODEL NUMBER	MINIMUM SPREAD	MAXIMUM SPREAD	UPPER BAIL (W x H)	LOWER BAIL (W x H)	HEAD ROOM	UNIFORM CAPACITY	WEIGHT (POUND)
<b>SBM-25</b> Ⓢ	8"	6'	2½" x 5"	1½" x 4½"	14¾"	2,500 lb.	146
<b>SBM-40</b> Ⓢ	8"	6'	3" x 5½"	2" x 4"	14¾"	4,000 lb.	170
<b>SBM-80</b> Ⓢ	8"	8'	4" x 7¼"	3" x 5½"	20¾"	8,000 lb.	350
<b>SM-LB-25</b> Ⓢ	ADDITIONAL LOWER BAIL FOR SBM-25						10
<b>SM-UB-25</b> Ⓢ	ADDITIONAL UPPER BAIL FOR SBM-25						11
<b>SM-LB-40</b> Ⓢ	ADDITIONAL LOWER BAIL FOR SBM-40						16
<b>SM-UB-40</b> Ⓢ	ADDITIONAL UPPER BAIL FOR SBM-40						17
<b>SM-LB-80</b> Ⓢ	ADDITIONAL LOWER BAIL FOR SBM-80						24
<b>SM-UB-80</b> Ⓢ	ADDITIONAL UPPER BAIL FOR SBM-80						33

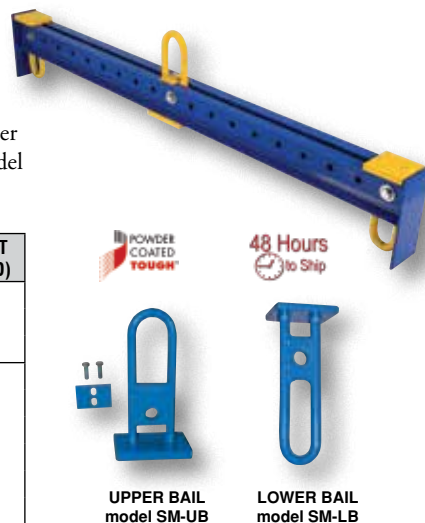

## Basket Lifting Beam

Lift uneven loads and keep them level with increased safety. Includes one upper bail and two specialty designed bail/sling holders. Bails are adjustable in 4" increments. The bails slide between two (2) 5" high C-Channels. Meets ASME B30.20-1993 standard. Baked-in powder-coated toughness. Polyester lifting slings sold separately on page 215.

MODEL NUMBER	MAXIMUM ARM WIDTH	MINIMUM ARM WIDTH	OVERALL WIDTH	UNIFORM CAPACITY	WEIGHT (POUND)
<b>SBM-40-BLB</b> Ⓢ	72"	16"	78"	4,000 lb.	176

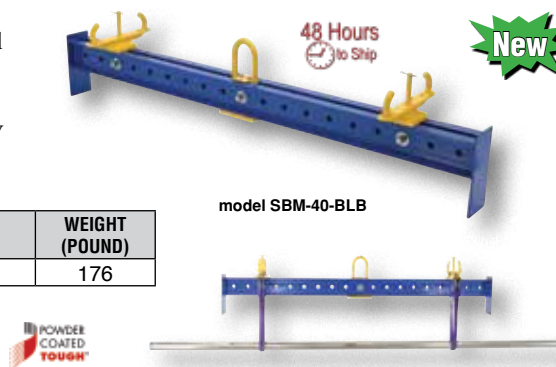



**PALLET LIFTERS**  
series HDP



**DELUXE ADJUSTABLE**  
model OLA-4-42-DLX

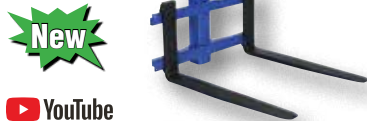

**FIXED FORKS**  
model OLF-4-42

**ADJUSTABLE**  
model OLA-4-42



model SC-6

48 Hours  
to Ship



model DLI-7

48 Hours  
to Ship

## Pallet Lifters

These solid steel constructed lifters contain tapered forks to allow easy access under pallets. Main support contains handles to allow personnel to position the unit. Large square head serves as a counterweight to keep the unit level without a load. Meets ASME B30.20 Standard 1993. Blue painted finish.

MODEL NUMBER	FORK LENGTH	OVERALL FORK WIDTH	FORK SIZE (W x H)	BAIL (W x H)	UNIFORM CAPACITY	WEIGHT (POUND)
HDP-2-36	36"	25"	2" x 2"	3" x 5"	2,000 lb.	436
HDP-2-42	42"	25"	2" x 2"	3" x 5"	2,000 lb.	470
HDP-2-48	48"	25"	2" x 2"	3" x 5"	2,000 lb.	474
HDP-4-36	36"	25"	4" x 2"	3" x 5"	4,000 lb.	629
HDP-4-42	42"	25"	4" x 2"	3" x 5"	4,000 lb.	658
HDP-4-48	48"	25"	4" x 2"	3" x 5"	4,000 lb.	693
HDP-6-42	42"	25"	6" x 2"	4" x 7"	6,000 lb.	675
HDP-6-48	48"	25"	6" x 2"	4" x 7"	6,000 lb.	744
HDP-6-54	54"	25"	6" x 2"	4" x 7"	6,000 lb.	1006

ADJUSTABLE BAIL, MODEL HDP-AB

## Overhead Load Lifters

Overhead Load Lifters are designed for lifting and moving pallets, skids, and crates with an overhead lifting crane. Includes an adjustable bail for keeping the load level when moving. Includes (3) three height positions. Welded steel construction with blue painted finish.

MODEL NUMBER	ADJUSTABLE CLEARANCE HEIGHT	OVERALL HEIGHT	USABLE FORK SIZE (W x L)	UNIFORM CAPACITY	WEIGHT (POUND)
<b>DELUXE WITH ADJUSTABLE FORKS 13" TO 38" O.D.</b>					
OLA-2-36-DLX	42¼", 54", 65¾"	65½", 77", 89½"	4" x 36"	2,000 lb.	527
OLA-2-42-DLX	42¼", 54", 65¾"	65½", 77", 89½"	4" x 42"	2,000 lb.	538
OLA-4-36-DLX	42¼", 54", 65¾"	65½", 77", 89½"	4" x 36"	4,000 lb.	547
OLA-4-42-DLX	42¼", 54", 65¾"	65½", 77", 89½"	4" x 42"	4,000 lb.	558
<b>ADJUSTABLE FORK WIDTH 17-5/8" TO 35-5/8"</b>					
OLA-2-42	40", 52", 64"	64", 76", 88"	4" x 43½"	2,000 lb.	531
OLA-4-42	40", 52", 64"	64", 76", 88"	4" x 43½"	4,000 lb.	537
<b>FIXED FORK WIDTH AT 27½"</b>					
OLF-2-42	38", 50", 62"	62", 74", 86"	4" x 43½"	2,000 lb.	488
OLF-4-42	38", 50", 62"	62", 74", 86"	4" x 43½"	4,000 lb.	491

## Crane Scales 6V DC STANDARD

Accuracy, quality, durability, and affordability are key attributes of the Crane Scales. Our digital hanging scales offer fast and reliable weighing in a compact and durable housing. Designed to withstand the most aggressive and heavy duty industrial lifting applications. Features: hook and shackle, rechargeable 6V battery, AC/DC power adapter, automatic shutoff, and convertible gross/net weight (5 digit) display. Each digit is ¾" wide by 1¼" high for easy readability. Accuracy is +/- 1%.

MODEL NUMBER	DESCRIPTION	OVERALL SIZE (W x D x H)	UNIFORM CAPACITY	WEIGHT (POUND)
SC-06	CRANE SCALES	7½" x 8" x 14"	600 lb.	22
SC-2	CRANE SCALES	7½" x 8" x 17"	2,000 lb.	30
SC-4	CRANE SCALES	7½" x 8" x 17"	4,000 lb.	32
SC-6	CRANE SCALES	7½" x 8" x 17"	6,000 lb.	33

## Digital Load Indicators

Incorporate this high tech gauge into your setup and read off the results. A strong, heavy duty tool which can withstand great weights and is exceedingly robust. Easy-to-read display and easy to use. The LCD display, which can tare as well as show either the gross or net load. Light weight, compact, and ergonomic design. Ideal for difficult conditions: access or sloping ground. It can be used in conjunction with shackles and hooks. Automatic stand-by for a prolonged battery life time. Suitable for operation in ambient temperatures of 14° through 104°F.

MODEL NUMBER	UNIFORM CAPACITY	PRECISION (POUND)	INDEXING ACCURACY	ACCURACY IN % OF NOMINAL LOAD	HOLE DIAMETER	HOLE DEPTH	WEIGHT (POUND)
DLI-05	500 lb.	4.4	1.1 lb.	0.20	1/2"	5/8"	2
DLI-1	1,000 lb.	9	1.1 lb.	0.10	1/2"	5/8"	2
DLI-2	2,000 lb.	18	4.4 lb.	0.20	1/2"	5/8"	2
DLI-4	4,000 lb.	33	11 lb.	0.25	7/8"	1"	2
DLI-7	7,000 lb.	55	11 lb.	0.16	7/8"	1"	2
DLI-14	14,000 lb.	100	20 lb.	0.16	1"	1"	2

## Winch Operated Truck Jib Cranes

Installed in your pick-up truck bed, this winch operated jib crane will help lift loads. Lift items from ground to truck bed height, then rotate into cargo area. Includes telescopic boom design with manual hydraulic hand pump to pivot boom up and down. Manual cable winch to lift and lower loads up to 500 pounds. Friction brake winch locks automatically when operator turns the handle counterclockwise to lower load. Cable usable length for all models 24' except WTJ-2 (9' model WTJ-2) with a diameter of 3/16". Unit comes with one (1) fixed hook, one (1) chain slot lock, and one (1) cable sling hook with latch. The crane swivels on a 360° base. Safety yellow, galvanized or stainless steel finish available. Welded steel construction. 12V DC power option available.

MODEL NUMBER	OPERATION	BOOM	FIXED HOOK CAPACITY	BOOM REACH	LIFT RANGE	WEIGHT (POUND)
<b>PAINTED SAFETY YELLOW FINISH</b>						
WTJ-2 <sup>Ⓢ</sup>	HAND	EXTENDED	500 lb.	54"	0 TO 102"	135
	PUMP	RETRACTED	1,000 lb.	30¼"	10" TO 89½"	
WTJ-4 <sup>Ⓢ</sup>	HAND	EXTENDED	1,000 lb.	44"	0 TO 86½"	145
	PUMP	RETRACTED	2,000 lb.	30"	13½" TO 77½"	
WTJ-2-DC	12V DC	EXTENDED	500 lb.	54"	0 TO 102"	160
		RETRACTED	1,000 lb.	30¼"	10" TO 89½"	
WTJ-4-DC	12V DC	EXTENDED	1,000 lb.	44"	0 TO 86½"	170
		RETRACTED	2,000 lb.	30"	13½" TO 77½"	
<b>GALVANIZED FINISH</b>						
WTJ-2-G <sup>Ⓢ</sup>	HAND	EXTENDED	500 lb.	52"	0 TO 86"	134
	PUMP	RETRACTED	1,000 lb.	30½"	5" TO 72"	
WTJ-4-G <sup>Ⓢ</sup>	HAND	EXTENDED	1,000 lb.	52"	0 TO 85⅞"	218
	PUMP	RETRACTED	2,000 lb.	31"	15½" TO 74½"	
WTJ-2-G-DC	12V DC	EXTENDED	500 lb.	52"	0 TO 86"	165
		RETRACTED	1,000 lb.	30½"	5" TO 72"	
WTJ-4-G-DC	12V DC	EXTENDED	1,000 lb.	52"	0 TO 85⅞"	245
		RETRACTED	2,000 lb.	31"	15½" TO 74½"	
<b>STAINLESS STEEL FINISH</b>						
WTJ-2-SS <sup>Ⓢ</sup>	HAND	EXTENDED	500 lb.	52"	0 TO 86"	134
	PUMP	RETRACTED	1,000 lb.	30½"	5" TO 72"	
WTJ-4-SS <sup>Ⓢ</sup>	HAND	EXTENDED	1,000 lb.	52"	0 TO 85⅞"	218
	PUMP	RETRACTED	2,000 lb.	31"	15½" TO 74½"	



model WTJ-2



48 Hours  
to Ship

**New**



model WTJ-2-G

CA Residents see WARNING A, Pg. 459

## Hitch-Mounted Truck Jib Crane

Hitch-Mounted Truck Jib Crane easily mounts in standard Class III or higher 2" receivers. Installation and use requires no modifications to receiver or truck. Unit may be adjusted/ leveled for best use in all conditions. Maximum uniform lifting capacity is 600 pounds. Manual hand brake winch with 25 feet of 3/16" diameter cable and lifting hook included. Offset upright design does not restrict tailgate use while installed. Crane may be installed on either side of truck as required. Rugged, welded steel construction with powder coat black finish.

MODEL NUMBER	MAXIMUM BOOM HEIGHT	BOOM REACH	OVERALL SIZE (W x L x H)	UNIFORM CAPACITY	WEIGHT (POUND)
WTJ-HITCH <sup>Ⓢ</sup>	84⅝"	47½"	19⅓/16" x 43⅞/16" x 74⅝/16"	600 lb.	168



model WTJ-HITCH

POWDER COATED TOUGH

YouTube



## Mechanical & Pneumatic Hoist Attachments

**Pneumatic Vacuum Lifter** is designed to lift products with smooth, flat, and non-porous surfaces. Push button to operate vacuum and grab product. Push button to release product. **Double Hook Lifter** is designed to lift virtually any type of object, either small or large, long or short, round or flat. Simple double-hook design with mechanical operation only.

MODEL NUMBER	DESCRIPTION	UNIFORM CAPACITY	WEIGHT (POUND)
VAC-6 <sup>Ⓢ</sup>	PNEUMATIC VACUUM	250 lb.	32
LMEC-DH	DOUBLE HOOK	250 lb.	20



PNEUMATIC VACUUM model VAC-6

Positioning of product is provided by a hoist or the Air Balance Jib Lifter.



DOUBLE HOOK model LMEC-DH

48 Hours  
to Ship



model DSJ-300

model DSL-300-P

## Air Balance Jib Lifters

These lifters achieve high performance, excellent safety, and low cost in the handling of heavy materials. Effortlessly handle materials in a three dimensional work space. The push-button hand control operates the pneumatic cylinder, raising and lowering the cable, in turn, positioning the load. Arm rotation is 360°. Air pressure 100 psi.

MODEL NUMBER	DESCRIPTION	UP/DOWN STROKE	MAXIMUM ARM LENGTH	UNIFORM CAPACITY	WEIGHT (POUND)
DSJ-300	FLOOR MOUNT	57½"	93"	250 lb.	647
DSL-300	FLOOR MOUNT	47¼"	78¼"	250 lb.	697
DSC-300	FLOOR MOUNT	78¾"	86½"	350 lb.	823
DSJ-300-P	PORTABLE	57½"	93"	250 lb.	1043
DSL-300-P	PORTABLE	47¼"	78¼"	250 lb.	1087
DSC-300-P	PORTABLE	78¾"	86½"	350 lb.	1219
DSJ-300-C	CEILING MOUNT	57½"	93"	250 lb.	471
DSL-300-C	CEILING MOUNT	47¼"	78¼"	250 lb.	515
DSC-300-C	CEILING MOUNT	78¾"	86½"	350 lb.	647

COILED HOSE FOR HAND CONTROL model DSJ-300-CH

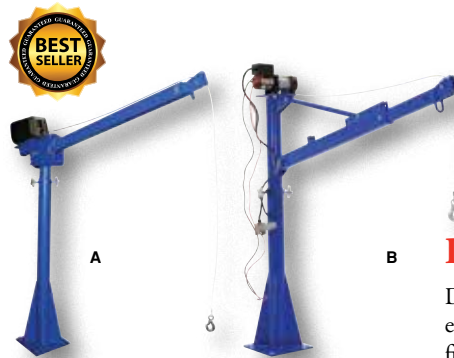

A

B

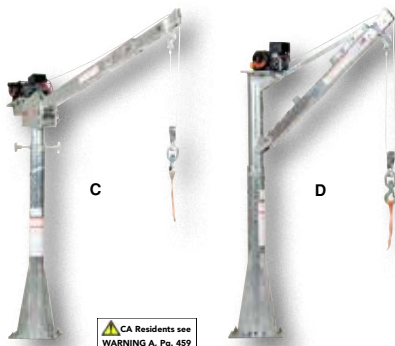

C

D

CA Residents see WARNING A, Pg. 459



48 Hours to Ship

YouTube

## Power Lift Jib Cranes 12V DC & 115V 1-PHASE AC STANDARD

Designed for material handling applications on docks, in warehouses, or in truck beds. Choose either 12V DC, 1 HP with 6' long non-removable pendant control or 115V AC, 1/3 HP with fingertip switch to raise and lower hook. Powered winches are designed for intermediate lifting. Meets ANSI and OSHA specifications. 12" x 12" mounting plate. Unit is designed for vertical lifting only. Do not use unit for lifting personnel or overhead lifting. Battery not included. Models with suffix -CSA feature a winch that meets Canadian requirements.

- A) Structural Jib Cranes feature rotation hand brakes that offer unlimited 360° manual positioning. Mast mounts permanently. Boom adjusts in 12" increments and can be positioned at 4 elevations. DC models include 46' of 3/16" aircraft-grade wire rope with swivel hook and safety latch. AC units feature 25' of 7/32" cable. Folds for storage. Blue painted finish.
- B) The economical answer to your material handling problems. Offers light-duty, intermittent use. Up to 1,500 pound uniform capacity at 27-13/16" boom extension. 360° locking manual rotation, 25' of 7/32" cable with hook on AC units. 46' of 3/16" cable on DC units. Blue painted finish.
- C) These cranes offer the same features as the Type A cranes with a galvanized finish.
- D) These cranes offer the same features as the Type B cranes with a galvanized finish.

ITEM	MODEL NUMBER	OPERATION	UNIFORM CAPACITY	BOOM REACH	BOOM HEIGHT	WEIGHT (POUND)
A	WTJ-20-3-DC	12V DC	2,000 lb.	39¼" to 63¼"	59 <sup>9</sup> / <sub>16</sub> " to 96 <sup>1</sup> / <sub>8</sub> "	261
A	WTJ-20-4-DC	12V DC	2,000 lb.	51¼" to 87¼"	59 <sup>1</sup> / <sub>2</sub> " to 106 <sup>1</sup> / <sub>2</sub> "	260
A	WTJ-20-3-AC	115V AC	2,000 lb.	39¼" to 63¼"	59 <sup>9</sup> / <sub>16</sub> " to 96 <sup>1</sup> / <sub>8</sub> "	280
A	WTJ-20-3-AC-CSA	115V AC	2,000 lb.	39¼" to 63¼"	59 <sup>9</sup> / <sub>16</sub> " to 96 <sup>1</sup> / <sub>8</sub> "	280
A	WTJ-20-4-AC	115V AC	2,000 lb.	51¼" to 87¼"	59 <sup>1</sup> / <sub>2</sub> " to 106 <sup>1</sup> / <sub>2</sub> "	290
A	WTJ-20-4-AC-CSA	115V AC	2,000 lb.	51¼" to 87¼"	59 <sup>1</sup> / <sub>2</sub> " to 106 <sup>1</sup> / <sub>2</sub> "	290
B	WTJ-E-15-3-DC	12V DC	1,500 lb.	43 <sup>1</sup> / <sub>16</sub> " to 66¾"	47 <sup>1</sup> / <sub>8</sub> " to 73 <sup>5</sup> / <sub>16</sub> "	213
B	WTJ-E-15-3-AC	115V AC	1,500 lb.	43 <sup>1</sup> / <sub>16</sub> " to 66¾"	47 <sup>1</sup> / <sub>8</sub> " to 73 <sup>5</sup> / <sub>16</sub> "	223
B	WTJ-E-15-3-AC-CSA	115V AC	1,500 lb.	43 <sup>1</sup> / <sub>16</sub> " to 66¾"	47 <sup>1</sup> / <sub>8</sub> " to 73 <sup>5</sup> / <sub>16</sub> "	223
C	WTJ-20-3-DC-GAL	12V DC	2,000 lb.	39¼" to 63¼"	59 <sup>9</sup> / <sub>16</sub> " to 96 <sup>1</sup> / <sub>8</sub> "	265
C	WTJ-20-4-DC-GAL	12V DC	2,000 lb.	51¼" to 87¼"	59½" to 106½"	266
C	WTJ-20-3-AC-GAL	115V AC	2,000 lb.	39¼" to 63¼"	59 <sup>9</sup> / <sub>16</sub> " to 96 <sup>1</sup> / <sub>8</sub> "	284
C	WTJ-20-3-AC-CSA-GAL	115V AC	2,000 lb.	39¼" to 63¼"	59 <sup>9</sup> / <sub>16</sub> " to 96 <sup>1</sup> / <sub>8</sub> "	284
C	WTJ-20-4-AC-GAL	115V AC	2,000 lb.	51¼" to 87¼"	59½" to 106½"	281
C	WTJ-20-4-AC-CSA-GAL	115V AC	2,000 lb.	51¼" to 87¼"	59½" to 106½"	281
D	WTJ-E-15-3-DC-GAL	12V DC	1,500 lb.	43 <sup>1</sup> / <sub>16</sub> " to 66¾"	47 <sup>1</sup> / <sub>8</sub> " to 73 <sup>5</sup> / <sub>16</sub> "	213
D	WTJ-E-15-3-AC-GAL	115V AC	1,500 lb.	43 <sup>1</sup> / <sub>16</sub> " to 66¾"	47 <sup>1</sup> / <sub>8</sub> " to 73 <sup>5</sup> / <sub>16</sub> "	223
D	WTJ-E-15-3-AC-CSA-GA	115V AC	1,500 lb.	43 <sup>1</sup> / <sub>16</sub> " to 66¾"	47 <sup>1</sup> / <sub>8</sub> " to 73 <sup>5</sup> / <sub>16</sub> "	223
<b>WINCH-AC-HHPB</b>		<b>UPGRADE AC WINCH WITH HANDHELD PUSH BUTTON CONTROL</b> (THIS OPTION REPLACES STANDARD FINGERTIP SWITCH ON AC WINCHES)				<b>5</b>

## Lifter Jibs

Lift items from the ground to van floor height, then rotate into cargo area. Hand winch, DC battery powered, and AC electrically powered winches are available. AC powered winch has a lift speed of 10 ft. per minute and DC powered at 7 ft. per minute at full capacity load. AC powered winch includes toggle switch. DC powered winch includes a pendant control. Battery powered winch includes 36" long leads. Battery not included. Van floor to raised hook height is 36 $\frac{1}{8}$ ". Double-pivot arm for use in tight spaces. Overall height is 46 $\frac{1}{16}$ ". Swing reach is 0" to 39 $\frac{3}{4}$ ". Steel construction. Painted finish. Unit is designed for vertical lifting only. Do not use unit for lifting personnel or overhead lifting.

MODEL NUMBER	DESCRIPTION	OVERALL CABLE LENGTH	UNIFORM CAPACITY	WEIGHT (POUND)
VAN-J <sup>Ⓢ</sup>	HAND WINCH	10 ft.	400 lb.	137
VAN-J-DC* <sup>Ⓢ</sup>	DC POWERED	46 ft.	400 lb.	145
VAN-J-AC	AC POWERED	25 ft.	400 lb.	275
WINCH-AC-HHPB	UPGRADE AC WINCH W/HANDHELD PUSH BUTTON CONTROL (THIS OPTION REPLACES STANDARD FINGERTIP SWITCH ON AC WINCHES)			5

\*VAN-J-DC INCLUDES BATTERY-POWERED WINCH WITH 46 FEET OF CABLE

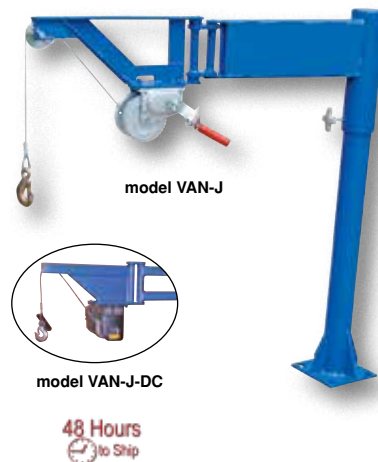

## Shop Crane Engine Hoists

These portable units are great for hundreds of lifting applications. Telescopic boom for multiple lifting heights and capacities. Boom is raised and lowered with a manual hydraulic hand pump. The high-capacity hydraulic cylinder provides faster lifting action and features a large diameter ram to withstand angled loads when lifting. Includes two (2) rigid and two (2) swivel casters for portability. Heavy-duty steel construction and painted finish.

MODEL NUMBER	UNIFORM CAPACITY	BOOM LENGTH	BOOM HEIGHT	WEIGHT (POUND)
<b>FOLDING DESIGN FOR STORAGE (33<math>\frac{1}{2}</math>"W x 44"L x 60<math>\frac{1}{2}</math>"H) -- (FOLDABLE LEGS)</b>				
EHN-20-C <sup>Ⓢ</sup>	2,000 lb.	36 $\frac{5}{8}$ "	20 $\frac{1}{2}$ " to 76"	207
	1,500 lb.	40"	17 $\frac{1}{2}$ " to 78"	
	1,000 lb.	43 $\frac{3}{4}$ "	14 $\frac{1}{2}$ " to 80"	
	500 lb.	47"	10 $\frac{1}{2}$ " to 82"	
EHN-40-C <sup>Ⓢ</sup>	4,000 lb.	39 $\frac{1}{4}$ "	21" to 85 $\frac{3}{4}$ "	238
	3,000 lb.	46 $\frac{1}{4}$ "	15" to 91 $\frac{1}{4}$ "	
	2,000 lb.	53 $\frac{1}{4}$ "	9" to 96 $\frac{9}{16}$ "	
	1,000 lb.	60 $\frac{1}{2}$ "	3" to 102"	
<b>FIXED - WILL NOT FOLD FOR STORAGE -- (TELESCOPIC LEGS)</b>				
EHN-40-T <sup>Ⓢ</sup>	4,000 lb.	49"	8 $\frac{7}{8}$ " to 72"	277
	3,000 lb.	58"	3 $\frac{1}{2}$ " to 77"	
	2,000 lb.	67"	0" to 82"	
	1,000 lb.	76"	0" to 87"	
EHN-60-T <sup>Ⓢ</sup>	6,000 lb.	51 $\frac{7}{8}$ "	22" to 84"	354
	4,000 lb.	60"	16 $\frac{11}{16}$ " to 88 $\frac{3}{16}$ "	
	3,000 lb.	68"	11 $\frac{1}{2}$ " to 92 $\frac{3}{8}$ "	
	2,000 lb.	76 $\frac{1}{4}$ "	6 $\frac{1}{4}$ " to 96 $\frac{9}{16}$ "	



## Air/Hand Pump Hydraulic Shop Crane

This crane allows one person to maneuver product from location to location, and then lift it with everyday factory air. If air is temporarily unavailable, lift product with the hand pump hydraulic option. Air raises unit 7" to 8" per second. Hand pump raises units  $\frac{1}{2}$ " per stroke. Units roll on 3 $\frac{1}{2}$ " x 1 $\frac{1}{4}$ " cast steel casters, (4) swivel in back (2) swivel in front. The hoist offers heavy-duty lifting power, while optimizing space when in the folded position. Standard features: foldable legs, adjustable boom, swivel hook, and steel construction.

MODEL NUMBER	UNIFORM CAPACITY	REACH	MAXIMUM HEIGHT	MINIMUM HEIGHT	WEIGHT (POUND)
<b>FOLDED SIZE: 33<math>\frac{1}{2}</math>"W x 44"L x 60<math>\frac{1}{2}</math>"H</b>					
EHN-40-C-AH <sup>Ⓢ</sup>	4,000 lb.	39"	86"	21"	249
	3,000 lb.	46"	91"	15"	
	2,000 lb.	53"	97"	9"	
	1,000 lb.	61"	102"	3"	



48 Hours  
to Ship

YouTube



model EPFC-25

model EPFC-25-AA

## Electric Powered Floor Cranes 24V DC POWERED

Fully powered shop cranes (power hoist & power in/out boom) for moving loads quickly, easily, and safely. 24V DC drive and lift motor handles heavy-duty jobs. Ergonomic handle features easy-to-operate throttle with infinite adjustment of forward and reverse speeds, lift/lower controls, proprietary safety-enhancing emergency reverse function, and horn. Includes an electromagnetic disc brake with automatic dead-man feature that activates when user releases the handle. Powered shop crane has two (2) 12V batteries, integral battery charger, and battery level gauge. Poly-on-steel steer and load wheels. 3-4 hour operation at full charge - 8 hours when used intermittently. Includes rigid hook with safety latch.

Model *EPFC-25* features adjustable length legs.

Model *EPFC-25-AA* features adjustable length legs and adjustable width legs.

Model *EPFC-CB-15* features fixed legs and counter balance design.

MODEL NUMBER	CAPACITY (RETRACTED)	CAPACITY (EXTENDED)	LIFT RANGE RETRACTED/EXTENDED	RETRACTED SIZE (W x L x H)	WEIGHT (POUND)
<b>EPFC-25</b> Ⓞ	2,500 lb.	600 lb.	44¼" - 97"	30" x 80" x 63"	1115
<b>EPFC-25-AA</b> Ⓞ	2,500 lb.	600 lb.	44¼" - 97"	30" x 80" x 63"	1160
<b>EPFC-CB-15</b>	1,500 lb.	400 lb.	44¼" - 97"	35" x 110" x 68"	1700
<b>EPFC-HC</b>	OPTIONAL FLOOR CRANE HAND CONTROL				3



series CBFC



## Counter Balanced Floor Cranes HAND PUMP OR 12V DC POWERED

This Crane has an adjustable boom to allow for maximum adjustment and versatility to lift a variety of loads. Boom is raised with a manual hydraulic hand pump or a push of a button on DC powered units. Boom also telescopes out for greater reach. The counterbalance design eliminates the need for front legs, making the unit easier to maneuver and ideal for reaching tight, hard to reach areas. Units roll on two (2) rigid 8" x 2" glass-filled nylon and two (2) swivel 8" x 3" phenolic caster with side brake. Counterbalance included. Welded steel construction with blue paint finish. Air operation available, contact factory.

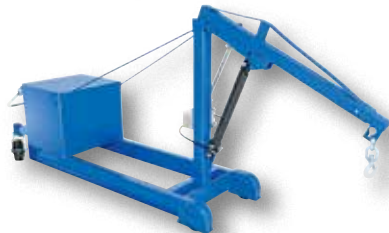

MODEL NUMBER	MAX UNIFORM CAPACITY	BOOM REACH	HOOK HEIGHT	OVERALL SIZE (W x L x H)	WEIGHT (POUND)
<b>HAND PUMP OPERATION</b>					
<b>CBFC-500</b>	500 lb.	39¼" - 63 <sup>5</sup> / <sub>16</sub> "	5" - 90"	29" x 135 <sup>1</sup> / <sub>8</sub> " x 102"	1259
<b>CBFC-1000</b>	1,000 lb.	39¼" - 63¼"	5" - 90"	29" x 145 <sup>1</sup> / <sub>4</sub> " x 102"	1845
<b>CBFC-2000</b>	2,000 lb.	39¼" - 63¼"	15" - 96"	29" x 159 <sup>1</sup> / <sub>8</sub> " x 107 <sup>1</sup> / <sub>2</sub> "	2736
<b>12V DC POWERED OPERATION</b>					
<b>CBFC-500-DC</b>	500 lb.	39¼" - 63 <sup>5</sup> / <sub>16</sub> "	5" - 90"	29" x 135 <sup>1</sup> / <sub>8</sub> " x 102"	1319
<b>CBFC-1000-DC</b>	1,000 lb.	39¼" - 63¼"	5" - 90"	29" x 145 <sup>1</sup> / <sub>4</sub> " x 102"	1905
<b>CBFC-2000-DC</b>	2,000 lb.	39¼" - 63¼"	15" - 96"	29" x 159 <sup>1</sup> / <sub>8</sub> " x 107 <sup>1</sup> / <sub>2</sub> "	2796

POWER TRACTION DRIVE SYSTEM, model CBFC-PTDS-E

**New**

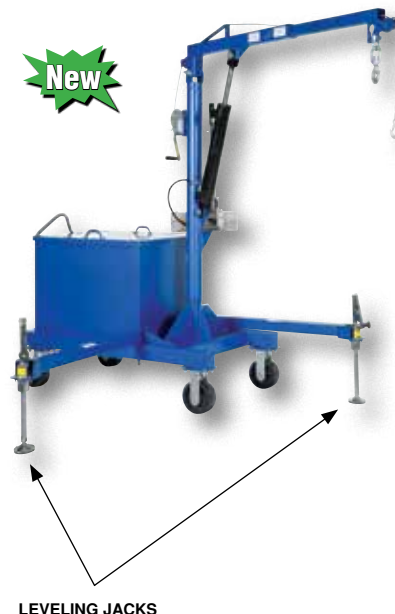

LEVELING JACKS

## Portable Cantilever Hoists

Portable Cantilever Hoists are swivel cranes for side loading and controlled lowering. The Hoist has outriggers to increase stability with a counter-balanced / cantilever design. Adjustable extendable boom swivels 360°. Maximum arm length beyond the frame is 50-3/8". Double acting hydraulic hand pump. Available with or without counter balancing ballast. Hand winch capacity is 800 pounds. \*GFN = glass filled nylon / PH = phenolic. Blue paint finish.

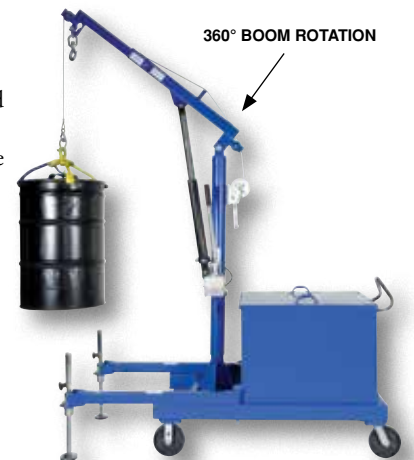

UNIFORM CAPACITY AT ARM LENGTH	P-JIB-2	P-JIB-4
24 <sup>3</sup> / <sub>8</sub> "	2,000 lb.	4,000 lb.
31 <sup>3</sup> / <sub>8</sub> "	1,600 lb.	3,200 lb.
38 <sup>3</sup> / <sub>8</sub> "	1,300 lb.	2,600 lb.
45 <sup>3</sup> / <sub>8</sub> "	1,100 lb.	2,200 lb.

MODEL NUMBER	OVERALL SIZE (W x L x H)	MAX. ARM LENGTH BEYOND FRAME	UNIFORM CAPACITY	CASTER SIZE/TYP*	WEIGHT (POUND)
<b>P-JIB-2</b>	35 <sup>11</sup> / <sub>16</sub> " x 113 <sup>13</sup> / <sub>16</sub> " x 89"	50 <sup>3</sup> / <sub>8</sub> "	2,000 lb.	8"x2" GFN	939
<b>P-JIB-4</b>	35 <sup>11</sup> / <sub>16</sub> " x 113 <sup>13</sup> / <sub>16</sub> " x 89"	50 <sup>3</sup> / <sub>8</sub> "	4,000 lb.	8"x3" PH	950
<b>P-JIB-BALL-2</b>	FACTORY SUPPLIED BALLAST FOR 2,000 LB. UNITS				2780
<b>P-JIB-BALL-4</b>	FACTORY SUPPLIED BALLAST FOR 4,000 LB. UNITS				3650



## Hoist Trailer

Unique hoist may be towed behind a car or truck to job site and then used for hundreds of applications. Includes a class 2 ball coupler accommodating a 1 7/8" ball and safety chains for use with most common hitches. Features two (2) large 16" diameter pneumatic wheels, two (2) swivel casters 4" x 2" in rear, two (2) rigid 5" x 2" in front, and one (1) swivel clevis hook with safety latch at the end of the boom. Telescoping lift arm and legs, as well as a removable jack handle standard. Welded steel construction with painted finish.



MODEL NUMBER	ARM LENGTH	RAISED HEIGHT	LOWERED HEIGHT	OVERALL SIZE (W x L)	UNIFORM CAPACITY	WEIGHT (POUND)
H-TRAIL	53 3/4"	78 3/8"	26 1/4"	47 1/2" x 71"	4,000 lb.	529
	65 3/4"	84 5/16"	20"	47 1/2" x 81 7/8"	1,150 lb.	
	77 3/4"	90"	13 3/4"	47 1/2" x 93 3/4"	650 lb.	

OPTIONAL BRAKE LIGHT KIT WITH WIRE HARNESS, MODEL H-TRAIL-HTH

## Pallet Truck Hoist

The Pallet Truck Hoist is an affordable and practical alternative for lifting and lowering loads to and from elevated work stations. It provides workers with a mobile lifting jib that quickly secures to a standard 27" x 48" pallet truck. Fork pockets measure 7 3/8"W x 1 7/8"H inside on 19 3/4" centers. Once installed, the pallet truck can still be used with most pallets and skids allowing for transport of heavy pallet loads, while retaining the ability to lift and lower loads to and from the pallet. It uses a clutchless cable winch with 80" of cable (88" with hook and shackle) for easy lifting and lowering. Lower load onto forks before moving. Steel construction with baked-in powder-coated toughness.

MODEL NUMBER	OVERALL HEIGHT	OVERALL BASE WIDTH	BOOM LENGTH	HOOK FROM UPRIGHT	UNIFORM CAPACITY	WEIGHT (POUND)
PJ-LIFT	77 1/4"	30"	21"	21"	500 lb.	210

PALLET TRUCK NOT INCLUDED



POWDER COATED TOUGH

## Tripod Hoist Stands

Portable and adjustable height tripod provides a convenient and economical lifting support stand. Independently adjustable legs enable use on uneven surfaces. Adjust leg height in six (6) inch increments. Unit folds for convenient portability and storage. Great for access to confined spaces. Features padded pivots for smooth or spiked feet. The spiked feet are designed to be used in rough terrain. A swivel eyebolt and safety chain are standard. Steel units have a painted blue finish. Chain hoist not included. Meets ANSI safety requirements for confined space Z117.1.

MODEL NUMBER	DESCRIPTION	EYELET HEIGHT MIN. / MAX.	UNIFORM CAPACITY	WEIGHT (POUND)
<b>STEEL CONSTRUCTION</b>				
TRI-SA	ADJUSTABLE HEIGHT LEGS	105" to 165 3/4"	2,000 lb.	322
TRI-SF	FIXED HEIGHT LEGS	107 3/4" (fixed)	2,000 lb.	250
<b>ALUMINUM CONSTRUCTION</b>				
TRI-AA	ADJUSTABLE HEIGHT LEGS	104 1/4" to 164 1/2"	1,000 lb.	247
TRI-AF	FIXED HEIGHT LEGS	104 1/2" (fixed)	1,000 lb.	215



SWIVEL EYEBOLT

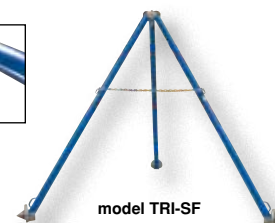

model TRI-SF

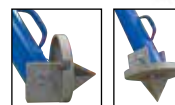

PADS PIVOT BETWEEN SPIKED & SMOOTH FEET

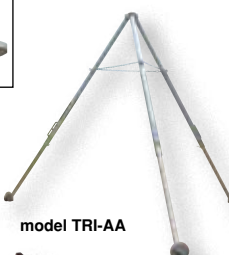

model TRI-AA

## Deluxe Drywall/Panel Hoist

Hoist lifts panels for installation on ceilings or walls up to 11 feet high. Synchronized telescoping mast action for fast and smooth raising/lowering. Easy winch operated and built-in brake mechanism. This hoist is affordable but very dependable with all welded steel and heavy duty construction. Dismantles to fit in the trunk of most cars. 360° swivel cradle to load panels vertically or horizontally.

MODEL NUMBER	SHEET SIZE CAPACITY	LOAD HEIGHT	MAXIMUM HEIGHT	UNIFORM CAPACITY	WEIGHT (POUND)
DPH-X-11	4' x 16'	58 1/2"	137"	150 lb.	141



48 Hours to Ship



### Hand Winches

**Wall Mounted Hand Winches** Pulling devices that use a wire, rope, cable, strap or web to move heavy loads. Constructed of steel worm gear drives. Pinion gear shaft with lubricated down bushings provide smooth operation and long life.

**Stainless Steel Hand Winches** are constructed of 304 stainless steel for corrosion resistance. Machine-cut spur gears ensure smooth accurate operation, while protective gear covers keep dirt out and help prevent worker injuries. Winches feature a drum clamp for easy attachment of wire rope (not included), and an automatic brake for positive load control during lifting and lowering operations.

MODEL NUMBER	TYPE	UNIFORM CAPACITY	GEAR RATIO	HANDLE LENGTH	WEIGHT (POUND)
WALL-S <sup>Ⓢ</sup>	SINGLE	1,500 lb.	41:1	9 <sup>5</sup> / <sub>8</sub> "	12
WALL-D <sup>Ⓢ</sup>	DOUBLE	1,500 lb.	41:1	6 <sup>5</sup> / <sub>8</sub> "	13
<b>STAINLESS STEEL</b>					
HWSS-1200-NR <sup>Ⓢ</sup>	SINGLE	1,200 lb.	4.2:1	8 <sup>1</sup> / <sub>4</sub> "	9
HWSS-1800-NR <sup>Ⓢ</sup>	SINGLE	1,800 lb.	5:1	12 <sup>1</sup> / <sub>2</sub> "	18
HWSS-2600-NR <sup>Ⓢ</sup>	SINGLE	2,600 lb.	10:1	12 <sup>1</sup> / <sub>2</sub> "	24



### Manual and Worm Gear Hand Winches

**Manual Hand-Operated Gear Drive Winch**, model HWG-600, is designed for many lifting, lowering, and pulling applications. Equipped with a load pressure brake. This brake holds the load at any required height during hoisting and lowering and prevents any unintentional lowering of the load. Adjustable crank handle for fast lifting of smaller loads, resulting in lowest possible handle effort and rapid winding of the rope. All rotating parts are maintenance-free. Suitable for operation in ambient temperatures of 14° through 120°F. Capacity 600 pounds.

**Worm Gear Hand Winch**, model HWV-1000, allows for better load control and features a reinforced frame comfort-grip handle. Worm gear provides load holding capability when handle is released. Reel stops automatically, locking load in place whenever the handle is released. High quality enamel paint finish, dipped and baked. Crank handle can be adjusted in length. Winch housing and rope drum are made from robust steel plate. Capacity 1,000 pounds.

MODEL NUMBER	GEAR TYPE	WIRE ROPE	DRUM CAPACITY (FT.)	OVERALL SIZE (L x W x H)	WEIGHT (POUND)
HWG-600 <sup>Ⓢ</sup>	MANUAL	3/16"	65	9 <sup>1</sup> / <sub>2</sub> " x 7 <sup>7</sup> / <sub>8</sub> " x 7 <sup>7</sup> / <sub>8</sub> "	36
HWV-1000 <sup>Ⓢ</sup>	WORM	1/4"	45	7" x 10 <sup>1</sup> / <sub>4</sub> " x 7"	35

CABLE IS NOT INCLUDED

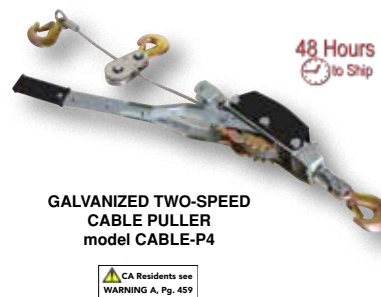

### Two-Speed Cable Puller

Great for use in horizontal pulling applications such as positioning equipment, stringing lines, and emergencies. Can be used in both single and double-line pulling applications. Handle ratchets to take up cable. When handle is rotated all the way back, the cable reel will free-spool. Handle length is 30". Minimum headroom is 24". Single-line cable length is 1/4" x 120" (cable length is 60" when used as a double-line). Not for use in vertical lifting applications.

MODEL NUMBER	SINGLE-LINE UNIFORM CAPACITY	DOUBLE-LINE UNIFORM CAPACITY	SINGLE-LINE CABLE LENGTH	WEIGHT (POUND)
CABLE-P4 <sup>Ⓢ</sup>	2,000 lb.	4,000 lb.	1/4" x 120"	14



### Long Reach Cable Pullers

Cable Pullers are ideal for applications requiring pulling over long distances. Pull up to 60' without unhooking and resetting as required when using conventional lever or hand chain hoists. Works great for pulling horizontally. Not for use in vertical lifting applications.

MODEL NUMBER	UNIFORM CAPACITY	USABLE CABLE LENGTH IN FEET (~m)	CABLE DIAMETER (APPROXIMATE)	WEIGHT (POUND)
CP-15 <sup>Ⓢ</sup>	1,500 lb.	60	5/16"	36
CP-30 <sup>Ⓢ</sup>	3,000 lb.	60	7/16"	64

\*MEETS CSIR FOR USE IN MINING INDUSTRY

## Sheet Handlers

Increase productivity with our Sheet Handlers. Handle even hot and oily material easily. Sheets may be stacked horizontally or vertically. Protect workers from cuts, slivers, nicks, and burns.

MODEL NUMBER	OVERALL SIZE (W x L x H)	MAXIMUM PENETRATION	WORKING UNIFORM CAPACITY	WEIGHT (POUND)
SHEET-50 <sup>Ⓢ</sup>	3 <sup>5</sup> / <sub>8</sub> " x 11 <sup>1</sup> / <sub>2</sub> " x 4"	3/ <sub>16</sub> "	50 lb.	5
SHEET-125 <sup>Ⓢ</sup>	7 <sup>1</sup> / <sub>4</sub> " x 11 <sup>1</sup> / <sub>2</sub> " x 4"	5/ <sub>16</sub> "	125 lb.	8
SHEET-200 <sup>Ⓢ</sup>	7 <sup>1</sup> / <sub>4</sub> " x 11 <sup>1</sup> / <sub>2</sub> " x 4"	5/ <sub>16</sub> "	200 lb.	8

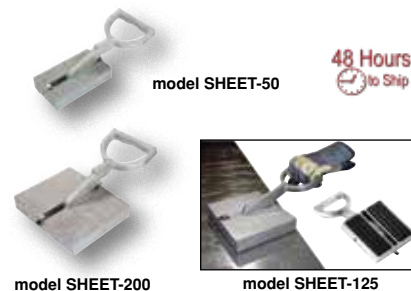

## Magnetic Lifters

Pick up sheets of material by use of overhead crane or chain with the permanent Magnetic Lifter. Magnet is activated or deactivated by simply rotating the lever. Units are lightweight, so transporting from work area to work area is convenient.

MODEL NUMBER	OVERALL SIZE (W x D x H)	BASE PLATE (W x L)	UNIFORM FLAT CAPACITY	UNIFORM ROUND CAPACITY	WEIGHT (POUND)
ML-2 <sup>Ⓢ</sup>	6 <sup>3</sup> / <sub>4</sub> " x 5 <sup>3</sup> / <sub>32</sub> " x 4 <sup>29</sup> / <sub>32</sub> "	2 <sup>1</sup> / <sub>2</sub> " x 3 <sup>5</sup> / <sub>8</sub> "	200 lb.	60 lb.	7
ML-6 <sup>Ⓢ</sup>	8 <sup>11</sup> / <sub>16</sub> " x 8" x 6 <sup>13</sup> / <sub>16</sub> "	3 <sup>5</sup> / <sub>8</sub> " x 6 <sup>1</sup> / <sub>2</sub> "	600 lb.	200 lb.	22
ML-12 <sup>Ⓢ</sup>	11" x 10 <sup>3</sup> / <sub>4</sub> " x 8 <sup>1</sup> / <sub>2</sub> "	5 <sup>1</sup> / <sub>2</sub> " x 8 <sup>3</sup> / <sub>4</sub> "	1,200 lb.	400 lb.	52



## Magnetic Easy Lift

Handheld lift grips parts with an easy to use trigger release. One handed operation. Permanent magnet in an aluminum housing moves parts faster and easier. Retrieve hot parts from cutting tables up to 300°F (148°C).

MODEL NUMBER	WIDTH	LENGTH	HEIGHT	WORKING CAPACITY	WEIGHT (POUND)
EASY-50 <sup>Ⓢ</sup>	2 <sup>3</sup> / <sub>8</sub> "	3 <sup>3</sup> / <sub>8</sub> "	4 <sup>13</sup> / <sub>16</sub> "	50 lb.	2



## Magnetic Catcher

Ideal for picking up small metallic objects. To use simply move over objects. To deactivate squeeze lever and the items will be released. Made of a hard plastic body with black steel handle.

MODEL NUMBER	WIDTH	LENGTH	HEIGHT	PULL FORCE	WEIGHT (POUND)
MLM-20 <sup>Ⓢ</sup>	3 <sup>13</sup> / <sub>16</sub> "	6"	8 <sup>1</sup> / <sub>4</sub> "	20 lb.	4



## Roto Grip Magnets

Effective holding against shear force. Securely grips heavy parts and will hold hot parts up to 300° (148°C). Rotate handle to discharge.

MODEL NUMBER	WIDTH	LENGTH	HEIGHT	WORKING CAPACITY	WEIGHT (POUND)
ROTO-25 <sup>Ⓢ</sup>	2"	2"	3/ <sub>4</sub> "	50 lb.	2
ROTO-50 <sup>Ⓢ</sup>	2 <sup>1</sup> / <sub>4</sub> "	4"	3/ <sub>4</sub> "	51 lb.	2
ROTO-90 <sup>Ⓢ</sup>	2 <sup>1</sup> / <sub>4</sub> "	5"	2"	92 lb.	2



